

HP 8340A SYNTHESIZED SWEEPER

10 MHz to 26.5 GHz

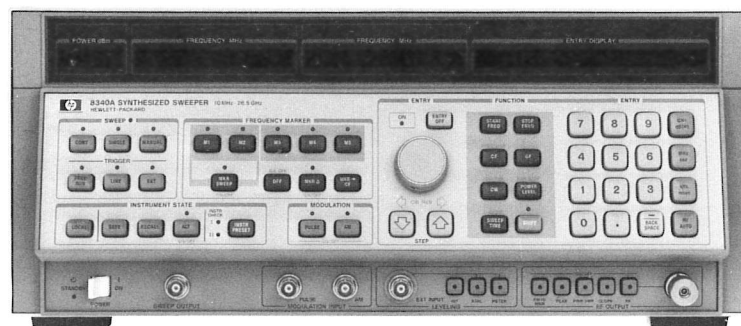

HP 8340A SYNTHESIZED SWEEPER (Including Options 001, 004, 005, 006, and 007)

SERIAL NUMBERS

This manual applies directly to the HP 8340A Synthesized Sweeper having a serial number prefix of 2513A.

For additional information about serial numbers, refer to INSTRUMENTS COVERED BY THE MANUAL IN Section I.

© Copyright HEWLETT-PACKARD COMPANY 1983
1400 FOUNTAINGROVE PARKWAY, SANTA ROSA, CA 95401, U.S.A.

MANUAL PART NO. 08340-90239
Microfiche Part No. 08340-90240

Printed: AUGUST 1985



**HEWLETT
PACKARD**

CERTIFICATION

Hewlett-Packard Company certifies that this product met its published specifications at the time of shipment from the factory. Hewlett-Packard further certifies that its calibration measurements are traceable to the United States National Bureau of Standards, to the extent allowed by the Bureau's calibration facility, and to the calibration facilities of other International Standards Organization members.

WARRANTY

This Hewlett-Packard instrument product is warranted against defects in material and workmanship for a period of one year from date of shipment, or, in the case of certain major components listed in section six of this Operating and Service manual, for the specified period. During the warranty period, Hewlett-Packard Company will, at its option, either repair or replace products which prove to be defective.

For warranty service or repair, this product must be returned to a service facility designated by HP. Buyer shall prepay shipping charges to HP and HP shall pay shipping charges to return the product to Buyer. However, Buyer shall pay all shipping charges, duties, and taxes for products returned to HP from another country.

LIMITATION OF WARRANTY

The foregoing warranty shall not apply to defects resulting from improper or inadequate maintenance by Buyer, Buyer-supplied software or interfacing, unauthorized modification or misuse, operation outside of the environmental specifications for the product, or improper site preparation or maintenance.

NO OTHER WARRANTY IS EXPRESSED OR IMPLIED. HP SPECIFICALLY DISCLAIMS THE IMPLIED WARRANTIES OF MERCHANTABILITY AND FITNESS FOR A PARTICULAR PURPOSE.

EXCLUSIVE REMEDIES

THE REMEDIES PROVIDED HEREIN ARE BUYER'S SOLE AND EXCLUSIVE REMEDIES. HP SHALL NOT BE LIABLE FOR ANY DIRECT, INDIRECT, SPECIAL, INCIDENTAL, OR CONSEQUENTIAL DAMAGES, WHETHER BASED ON CONTRACT, TORT, OR ANY OTHER LEGAL THEORY.

ASSISTANCE

Product maintenance agreements and other customer assistance agreements are available for Hewlett-Packard products.

For any assistance, contact your nearest Hewlett-Packard Sales and Service Office. Addresses are provided at the back of this manual.

VOLUME 1 CONTENTS

| Section | Page | Section | Page |
|---------------------------|------------------------------------|------------------------------------|-----------------------------------|
| I | GENERAL INFORMATION | 2-19. | HP-IB, 8410, and 8755 Interface |
| 1-1. | Introduction | Connectors | 2-4 |
| 1-7. | Specifications | 2-21. | Internal Oscillator Selection and |
| 1-9. | Safety Considerations | Warmup Time | 2-4 |
| 1-11. | Instruments Covered by Manual | 2-24. | Operating Environment |
| 1-16. | Description | 2-25. | Temperature |
| 1-25. | Options | 2-26. | Humidity |
| 1-26. | Option 001, Front Panel RF Output, | 2-27. | Altitude |
| No Attenuator | 1-3 | 2-28. | Cooling |
| 1-28. | Option 004, Rear Panel RF Output | 2-29. | Front Handles Kit |
| with 90 dB Attenuator | 1-3 | 2-31. | Chassis Slide Kit (Option 806) |
| 1-30. | Option 005, Rear Panel RF | 2-33. | Rack Flange Kit (Option 908) |
| OUTPUT with No Attenuator | 1-3 | 2-35. | Rack Mounting with Handles |
| 1-32. | Option 006, Delete Pulse | (Option 913) | 2-9 |
| Modulation | 1-3 | 2-37. | Storage and Shipment |
| 1-33. | Option 007, Relaxed Phase Noise | 2-38. | Environment |
| Specifications | 1-3 | 2-41. | Packaging |
| 1-34. | Option 806, Chassis Mount | 2-42. | Original Packaging |
| Slide Kit | 1-3 | 2-43. | Other Packaging |
| 1-36. | Option 850, Model 8410B/C | 2-44. | Blue Service Tags |
| Interface | | 2-46. | Incoming Inspection |
| Cable | 1-4 | Procedure | 2-9 |
| 1-38. | Option 908, Rack Flanges without | III | OPERATING INFORMATION |
| Handles Kit | 1-4 | Introduction | 3-1 |
| 1-40. | Option 910, Extra Manual Set | LOCAL OPERATING INFORMATION | |
| 1-42. | Option 913, Rack Flanges with | Power dBm display | 3-7 |
| Handles Kit | 1-4 | START/CW/CF Frequency Display | 3-9 |
| 1-44. | Option 914, Delete Service | STOP/ Δ F Frequency Display | 3-10 |
| Documentation | 1-4 | Entry Display | 3-11 |
| 1-46. | Equipment Required But | Function | 3-13 |
| Not Supplied | 1-4 | KNOB/STEP Entry | 3-16 |
| 1-49. | Equipment Available | Frequency Marker | 3-17 |
| 1-50. | Service Accessories | Entry | 3-20 |
| 1-52. | Model 8410C/8411A Network | Sweep and Trigger | 3-22 |
| Analyzer | 1-4 | Instrument State | 3-25 |
| 1-54. | HP Model 8755 Frequency | Power Switch, Sweep Output | 3-27 |
| Response Test Set | 1-5 | Modulation | 3-28 |
| 1-57. | HP Model 8756A Scalar Network | Modulation Input | 3-29 |
| Analyzer | 1-5 | Leveling | 3-30 |
| 1-59. | Power Meters and Crystal | RF Output | 3-32 |
| Detectors | 1-5 | Rear Panel BNC Connectors | 3-35 |
| 1-61. | Recommended Test Equipment | Rear Panel RF Output | 3-37 |
| II | INSTALLATION | HP-IB Connector | 3-38 |
| 2-3. | Initial Inspection | HP 8410 Interface | 3-40 |
| 2-5. | Preparation For Use | HP 8755C Interface | 3-42 |
| 2-6. | Power Requirements | Fan Assembly | 3-43 |
| 2-8. | Line Voltage and Fuse Selection | Power Line Module | 3-44 |
| 2-10. | Power Cable | HP-IB PROGRAMMING | |
| 2-13. | HP-IB Address Selection | INFORMATION | 3-45 |
| 2-15. | Interface Function Codes | Introduction | 3-45 |
| 2-17. | Mating Connectors | | |

VOLUME 1 CONTENTS (Cont'd)

| Section | Page | Section | Page |
|---|-------|--|-------|
| Interconnective Cabling | 3-45 | Response Time | 3-110 |
| Instrument Addresses | 3-45 | Unleveled Mode Used with | |
| HP-IB Instruments Nomenclature | 3-45 | Pulse Modulation | 3-110 |
| Programming the HP 8340A | 3-45 | Input Characteristics | 3-111 |
| HP-IB Command Statements | 3-46 | Pulse Envelope | 3-112 |
| HP 8340A Programming Codes | 3-51 | Source Match | 3-112 |
| Programs that Duplicate Front | | Video Feedthrough | 3-112 |
| Panel Operations | 3-51 | FURTHER INFORMATION | 3-113 |
| Using the Rotary KNOB | 3-56 | | |
| Using Keys that Toggle ON/Off | 3-56 | IV PERFORMANCE TESTS | 4-1 |
| Operator's Programming Check | 3-56 | 4-1. Introduction | 4-1 |
| Unique HP-IB Programming Codes | 3-57 | 4-3. Equipment Required | 4-1 |
| System Timing | 3-77 | 4-5. Test Record | 4-1 |
| HP-IB Programming Techniques for | | 4-7. Calibration Cycle | 4-1 |
| Special Applications | 3-77 | 4-9. Internal Time Base | |
| HP-IB Pin-Out Description | 3-78 | Aging Rate | 4-3 |
| The Twelve HP-IB Messages | 3-81 | 4-10. Frequency Range and CW | |
| Computer Access of HP-IB Lines | 3-88 | Mode Accuracy | 4-6 |
| Sending HP-IB Messages | 3-88 | 4-11. Sweep Time Accuracy | 4-12 |
| Reading HP-IB Messages | 3-89 | 4-12. Swept Frequency Accuracy | 4-14 |
| Direct Writing to the HP-IB Lines | 3-91 | 4-13. Maximum Leveled Output Power and | |
| POWER CONTROL AND MODULATION | | Power Accuracy Test | 4-18 |
| INFORMATION | 3-94 | 4-14. External Leveling | 4-26 |
| INTERNAL LEVELING | 3-94 | 4-15. Spurious Signals Test | |
| Coupled Mode | 3-94 | (10 MHz to 22 GHz) | 4-30 |
| Power dBm Display | 3-95 | 4-16. Spurious Signals Test | |
| Decoupled Mode | 3-96 | (22 to 26.5 GHz) | 4-33 |
| UNLEVELED MODE | 3-98 | 4-17. Single Sideband Phase Noise | 4-36 |
| EXTERNAL LEVELING | 3-100 | 4-18. Power Sweep Test | 4-43 |
| Detector Characteristics | 3-101 | 4-19. Pulse Modulation On/Off | |
| POWER dBm Display used with | | Ratio Test | 4-46 |
| the Attenuator | 3-103 | 4-20. Pulse Modulation Rise and Fall | |
| Bandwidth | 3-103 | Time Test | 4-48 |
| AMPLITUDE MODULATION | 3-105 | 4-21. Pulse Modulation Accuracy Test .. | 4-52 |
| Power dBm Display used with AM .. | 3-105 | 4-22. Pulse Modulation Video Feedthrough | |
| Dynamic Range | 3-105 | Test | 4-56 |
| Bandwidth for AM Applications | 3-106 | 4-23. Amplitude Modulation Test | 4-60 |
| PULSE MODULATION | 3-106 | 4-24. 8340A HP-IB Operation | |
| Sample and Hold Leveling | 3-106 | Verification Test | 4-65 |

TABLES

| Table | Page | Table | Page |
|---|------|---|------|
| 1-1. Model HP 8340A Specifications and Supplemental Performance Characteristics | 1-6 | 4-14. dBV vs Voltage Reference Table | 4-29 |
| 1-2. Recommended Test Equipment | 1-21 | 4-15. Spurious Signals Test (10 MHz to 22 GHz) Specifications | 4-30 |
| 2-1. Line Voltage/Fuse Selection | 2-2 | 4-16. Spurious Signals Test (20 to 26.5 GHz) Specifications | 4-33 |
| 2-2. AC Power Cables Available | 2-3 | 4-17. Single-sideband Phase Noise Specifications | 4-36 |
| 2-3. Model 8340A Mating Connectors | 2-5 | 4-18. Phase Noise Calibration Data | 4-39 |
| 3-1. Index by Mode and Function | 3-4 | 4-19. Phase Noise Measurement Data | 4-40 |
| 3-2. HP 8340A Programming Codes | 3-53 | 4-20. Phase Noise Test Frequencies | 4-41 |
| 3-3. The Standard ASCII Code | 3-85 | 4-21. Phase Noise Test Results | 4-42 |
| 4-1. List of Manual Performance Tests | 4-2 | 4-22. Power Sweep Test Specifications | 4-43 |
| 4-2. Internal Time Base Aging Rate Specifications | 4-3 | 4-23. Pulse Modulation ON/OFF Ratio Test Specifications | 4-46 |
| 4-3. Frequency Range and CW Mode Accuracy Specifications | 4-6 | 4-24. Pulse Modulation Rise and Fall Time Test Specification | 4-48 |
| 4-4. Sweep Time Accuracy Specifications | 4-12 | 4-25. Pulse Modulation Accuracy Test Specifications | 4-52 |
| 4-5. Sweep Time Accuracy Limits | 4-13 | 4-26. Pulse Modulation Video Feedthrough Test Specification | 4-56 |
| 4-6. Swept Frequency Accuracy Specifications | 4-14 | 4-27. Pulse Modulation Video Feedthrough Test Limits | 4-58 |
| 4-7. Swept Frequency Accuracy Test Frequencies | 4-17 | 4-28. Amplitude Modulation Test Specifications | 4-60 |
| 4-8. Maximum Leveled Output Power and Power Accuracy Specifications | 4-18 | 4-29. 8340A Status Byte Description | 4-67 |
| 4-9. Maximum Leveled Output Power Test Work Sheet | 4-24 | 4-30. 8340A HP-IB Operation Verification Programming Listing (For Use With HP 85F) | 4-68 |
| 4-10. External Leveling Specifications | 4-26 | 4-31. 8340A HP-IB Operation Verification Programming Listing (For Use With HP 9826A or 9836A) | 4-69 |
| 4-11. External Leveling Limits (With No Attenuator) | 4-27 | 4-32. 8340A Test Record Card | 4-70 |
| 4-12. External Leveling Limits (With 10 dB Attenuator) | 4-28 | | |
| 4-13. External Leveling Limits (With 20 dB Attenuator) | 4-28 | | |

SAFETY CONSIDERATIONS

GENERAL

This product and related documentation must be reviewed for familiarization with safety markings and instructions before operation. This product has been designed and tested in accordance with international standards.

SAFETY SYMBOLS



Instruction manual symbol: the product will be marked with this symbol when it is necessary for the user to refer to the instruction manual (refer to Table of Contents).



Indicates hazardous voltages.



Indicates earth (ground) terminal.

WARNING

The WARNING sign denotes a hazard. It calls attention to a procedure, practice, or the like, which, if not correctly performed or adhered to, could result in personal injury. Do not proceed beyond a WARNING sign until the indicated conditions are fully understood and met.

CAUTION

The CAUTION sign denotes a hazard. It calls attention to an operating procedure, practice, or the like, which, if not correctly performed or adhered to, could result in damage to or destruction of part or all of the product. Do not proceed beyond a CAUTION sign until the indicated conditions are fully understood and met.

SAFETY EARTH GROUND

This is a Safety Class I product (provided with a protective earthing terminal). An uninterruptible safety earth ground must be provided from the main power source to the product input wiring terminals, power cord, or supplied power cord set. Whenever it is likely that the protection has been impaired, the product must be made inoperative and be secured against any unintended operation.

BEFORE APPLYING POWER

Verify that the product is configured to match the available main power source per the input power configuration instructions provided in this manual.

If this product is to be energized via an autotransformer make sure the common terminal is connected to the neutral (grounded side of mains supply).

SERVICING

WARNING

Any servicing, adjustment, maintenance, or repair of this product must be performed only by qualified personnel.

Adjustments described in this manual may be performed with power supplied to the product while protective covers are removed. Energy available at many points may, if contacted, result in personal injury.

Capacitors inside this product may still be charged even when disconnected from its power source.

To avoid a fire hazard, only fuses with the required current rating and of the specified type (normal blow, time delay, etc.) are to be used for replacement.

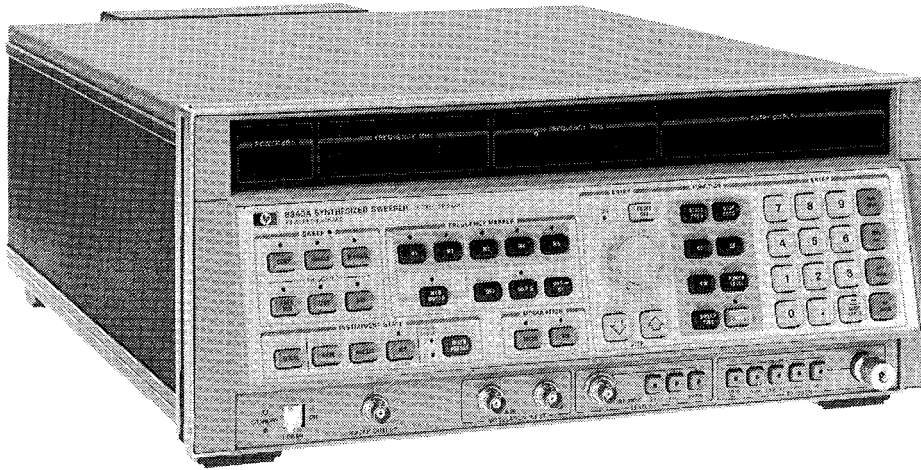

HP 8340A SYNTHESIZED SWEEPER

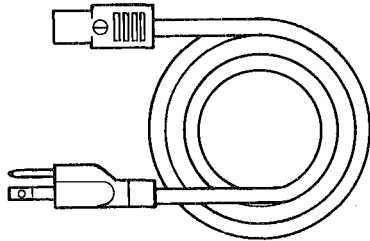

POWER CABLE*

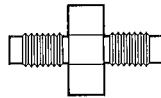

HP Part No. 5061-5311
APC 3.5 (F) TO
APC 3.5 (F) ADAPTER



HP Part No. 1250-1745
APC 3.5 (F) TO
TYPE N (F) ADAPTER

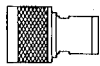

HP Part No. 1250-1854
50Ω TERMINATION
(For AUX OUTPUT)

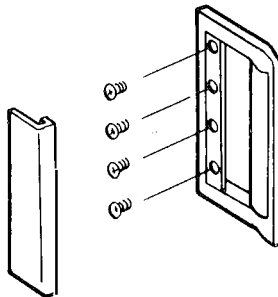

HP Part No. 5061-9690
HANDLES KIT

* POWER CABLE/PLUG SUPPLIED DEPENDS ON COUNTRY OF SHIPMENT DESTINATION. REFER TO SECTION II, INSTALLATION FOR PART NUMBER INFORMATION.

Figure 1-1. Model 8340A with Accessories Supplied

SECTION I GENERAL INFORMATION

1-1. INTRODUCTION

1-2. This Operating and Service Manual contains information required to install, operate, test, adjust, and service the Hewlett-Packard Model 8340A Synthesized Sweeper. Figure 1-1 shows the 8340A with accessories supplied.

1-3. The complete 8340A manual set consists of four volumes, divided into eight major sections, which provide the following information:

Volume I

- SECTION I, GENERAL INFORMATION, includes a brief description of the instrument and its documentation layout, safety considerations, specifications and supplemental performance characteristics, instrument identification, options available, accessories available, and a list of recommended test equipment.
- SECTION II, INSTALLATION, provides information for initial inspection, preparation for use, storage, and shipment.
- SECTION III, OPERATION, is subdivided into five sections that describe the instrument's features, how to manually and remotely control instrument operation, and how to interface the 8340A with other compatible instruments.
- SECTION IV, PERFORMANCE TESTS, presents procedures required to verify that the performance of the instrument is in accordance with published specifications. An HP-IB Operation Verification procedure is also included to test the ability of the 8340A to properly communicate on the HP-IB bus. A section is provided for Automated Test Procedures using a computing controller. These are additional or duplicate tests of the Performance Tests and/or Adjustment procedures.

Volume II

- SECTION IV, PERFORMANCE TESTS, is duplicated in this section.
- AUTOMATED TEST PROCEDURE, provides the procedure for performing automated Frequency Switching and RF attenuator performance tests. Automated Test Procedure software and either an HP 9826A or HP 9836A controller are required for this test. Refer to Table 1-2 for further information.
- SECTION V, ADJUSTMENTS, presents procedures required to properly adjust and align the 8340A after repair.
- SECTION VI, REPLACEABLE PARTS, provides information required to order all parts and assemblies contained in the 8340A.
- SECTION VII, MANUAL BACKDATING CHANGES, provides backdating information required to make this manual compatible with earlier shipment configurations.

Volumes 3 and 4

- SECTION VIII, SERVICE, includes information to troubleshoot and repair instrument problems.

The Service Section begins with a Service Introduction that describes the section layout and overall instrument theory and troubleshooting concepts. The Service Introduction section then leads the troubleshooter into one of eight Functional Groups, each describing a set of assemblies that serve as a functional unit.

Each Functional Group area includes more detailed information that will lead the troubleshooter to a specific assembly within that group.

Each assembly is then supported with its own separate circuit description, schematic diagram, component location diagram, and troubleshooting information to lead the troubleshooter to the specific circuit or component at fault.

1-4. Supplied with this manual is a User's Manual. The User's Manual is a copy of the information supplied in Sections I through III of this manual. This copy is intended to be kept with the instrument for use by the instrument operator. Additional copies are available; refer to HP Part Number information of the manuals on the title page of this volume.

1-5. On the title page of this volume is a "Microfiche" part number. This number may be used to order 10- by 15- centimeter (4- by 6-inch) microfilm transparencies of the complete manual. Each microfiche page contains up to 60 photo duplicates of the manual pages. The microfiche package also includes the latest Manual Changes sheet as well as all pertinent Service Notes.

1-6. Refer any questions regarding this manual, the Manual Changes sheet, or the instrument to the nearest HP Sales/Service Office. Always identify the instrument by model number, complete name, and complete serial number in all correspondence. Refer to the last tab section in Volume 4 for a worldwide listing of HP Sales/Service Offices.

1-7. SPECIFICATIONS

1-8. Listed in Table 1-1 are the specifications for the 8340A; specifications are shaded in the table. These specifications are the performance standards, or limits, against which the instrument may be tested. Also listed in Table 1-1 are the supplemental performance characteristics (not shaded). Supplemental performance characteristics are not specifications but are typical characteristics included as additional information for the user.

1-9. SAFETY CONSIDERATIONS

1-10. This product has been manufactured and tested in accordance with international safety standards. Before operation, this product and related documentation must be reviewed for familiarization with safety markings and instructions. A complete listing of Safety Considerations precedes Section I of this manual.

1-2

1-11. INSTRUMENTS COVERED BY MANUAL

1-12. Attached to the rear panel of the instrument is a serial number plate. A typical serial number plate is shown in Figure 1-2. The serial number is in two parts. The first four digits followed by a letter comprise the serial number prefix. The last five digits form the sequential suffix that is unique to each instrument. The content of this manual applies directly to instruments having the same serial number prefix as those listed on the title page of this manual under SERIAL NUMBER.

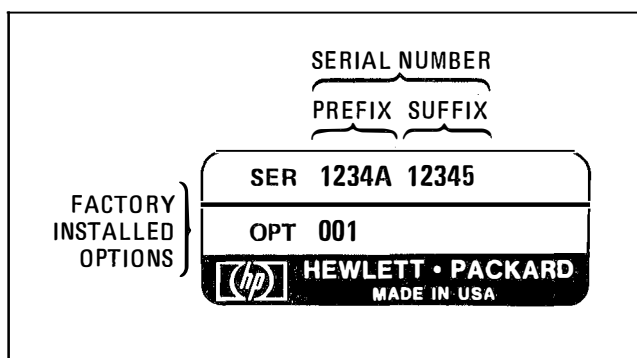

Figure 1-2. Typical Serial Number Plate

1-13. An instrument manufactured after the printing of this manual may have a serial prefix that is not listed on the title page. An unlisted serial prefix indicates that the instrument is different from those documented in this manual. The manual for the instrument is then supplied with a Manual Changes Supplement that documents the differences.

1-14. In addition to change information, the Manual Changes Supplement contains information for correcting errors in the manual. To keep this manual as current as possible, Hewlett-Packard recommends that you periodically request the latest Manual Changes Supplement. The supplement for this manual is keyed to the manual's print date and part number, both of which appear on the title page. Complimentary copies of the Manual Changes Supplement are available on request from Hewlett-Packard.

1-15. For information concerning a serial number prefix that is not listed on the title page or in the Manual Changes Supplement, contact your nearest Hewlett-Packard Sales/Service Office.

1-16. DESCRIPTION

1-17. The HP Model 8340A Synthesized Sweeper is a broadband, analog sweep, frequency synthesizer with versatile modulation and output power control.

1-18. The 8340A generates synthesized output frequencies from 10 MHz to 26.5 GHz. Frequency resolution from 1 Hz at 10 MHz to 4 Hz at 26.5 GHz is available. Frequency accuracy is a function of the internal time base accuracy or an external frequency standard. Harmonically-related signals are at least 35 dB below the carrier (-35 dBc) and nonharmonically-related spurious outputs are at least -55 dBc.

1-19. The 8340A features AM modulation rates from dc to 100 kHz. Pulse modulation circuitry allows rise and fall times of <25 nanoseconds, an ON/OFF ratio of > 80 dB, and will pass pulses as narrow as 100 nanoseconds.

1-20. Maximum calibrated output power from the APC 3.5 RF OUTPUT connector is $\leq +9$ dBm from 10 MHz to 20 GHz and $\leq +1$ dBm from 20 GHz to 26.5 GHz. The lowest output power available in all bands is -110 dBm. Displayed power resolution is 0.05 dB. A Power Sweep function provides the ability to sweep power up to 40 dB.

1-21. The 8340A is capable of generating a true analog sweep across its entire 10 MHz to 26.5 GHz frequency range. Additionally, a synthesized sweep mode allows precision analog sweeps as narrow as 100 Hz.

1-22. Additional features include five calibrated frequency markers and various sweep modes oriented around stored marker positions. The ability to Save and Recall up to 9 front panel settings also allows an Alternate Sweep function.

1-23. The front panel ENTRY DISPLAY shows the current active function and its appropriate values. Data entry is quickly accomplished through the use of the numeric keyboard, step keys, or RPG (Rotary Pulse Generator) control. All front panel functions, except the lines switch, are programmable through the HP-IB bus.

1-24. Many serviceability features have also been incorporated in the 8340A. An internal SELF TEST is run each time the instrument is turned on or when the front panel INSTR PRESET key is pressed. Front panel diagnostic routines are

accessible to aid in fault detection and isolation. Additional detailed information on troubleshooting and repair procedures is included in Appendix A, In Case of Difficulty, in this volume. This information is also included in Section VIII, Service, in Volumes 3 and 4.

1-25. OPTIONS

1-26. Option 001, Front Panel RF Output, No Attenuator

1-27. The standard instrument configuration has a front panel RF OUTPUT connector and a 90 dB programmable attenuator. Option 001 instruments do not have the 90 dB programmable attenuator. The lower limit of the output power range is then -20 dBm.

1-28. Option 004, Rear Panel RF Output with 90 dB Attenuator

1-29. Option 004 instruments have the RF OUTPUT connector mounted on the rear panel instead of the front panel. The 90 dB Programmable Attenuator is installed, thereby allowing the output power level to be set as low as -110 dBm.

1-30. Option 005, Rear Panel RF OUTPUT with No Attenuator

1-31. Option 005 instruments have the RF OUTPUT connector mounted on the rear panel and the 90 dB Programmable Attenuator is deleted. The lower limit of the output power level is then -20 dBm.

1-32. Option 006, Delete Pulse Modulation

1-32a. The pulse modulation specifications of the standard HP 8340A are no longer applicable. However, HP 8340A Option 006 is still compatible with the 27.8 kHz squarewave modulation needed to make it operate with HP 8756A or HP 8755 scalar network analyzers.

1-33. Option 007, Relaxed Phase Noise Specifications

1-33a. Instruments equipped with this option are warranted to perform within a relaxed phase noise specification.

1-34. Option 806, Chassis Mount Slide Kit

1-35. This kit includes the necessary hardware to mount sliding rack mounts on the 8340A. This allows easier access to the 8340A when mounted in an equipment rack. It is necessary to remove the instrument side panels in order to

install the kit. This is described in detail in Section II, Installation, in this volume.

1-36. Option 850, Model 8410B/C Interface Cable

1-37. This cable permits multi-octave operation of the Model 8410B/C Network Analyzer with the 8340A. This cable is also available separately as HP Part Number 08410-60146. Detailed operation instructions for the use of this cable are included in Section III, Operation, in this volume.

1-38. Option 908, Rack Flanges without Handles Kit

1-39. Option 908 contains a pair of flanges and the necessary hardware to mount the 8340A in an equipment rack with 482.6mm (19 inches) horizontal spacing. Refer to Section II, Installation, in this volume for a detailed description of the parts in this kit and for installation instructions.

1-40. Option 910, Extra Manual Set

1-41. Each instrument is supplied with one complete copy of the four-volume Operating and Service Manual binder set (refer to Option 914). Each Option 910 ordered provides one additional manual binder set. To obtain additional Operating and Service Manual binder sets after receiving the initial instrument shipment, order by manual part number, listed on the title page of this volume. The title page also lists part numbers of manual parts that are individually available.

1-42. Option 913, Rack Flanges with Handles Kit

1-43. Option 913 contains a pair of flanges, a pair of handles, and the necessary mounting hardware to mount the instrument in an equipment rack with 482.6mm (19 inches) horizontal spacing. This kit differs from Option 908 kits in that the flanges accommodate the added handles. This makes it easier to hold and position the instrument when installing or removing the instrument from the rack, or, when handling the instrument on a bench. Detailed installation instructions for this kit are included in Section II, Installation.

1-44. Option 914, Delete Service Documentation

1-45. Option 914 orders delete Volumes 2, 3, and 4. This allows customers with more than one instrument to reduce the cost and space requirements for duplicate documentation materials.

1-46. EQUIPMENT REQUIRED BUT NOT SUPPLIED

1-47. The 8340A is ready for use as received; no additional equipment is required for manual operation (from the front panel controls) other than standard cables and adapters required for the specific application.

1-48. To use the HP-IB capabilities of the 8340A, a computing controller, such as the HP 85, HP 9826, or HP 9836 is required.

1-49. EQUIPMENT AVAILABLE

1-50. Service Accessories

1-51. A Service Accessory Kit is available as HP Part Number 08340-60134. This kit includes a variety of extender boards, cables, and adapters that will aid in servicing the 8340A.

1-52. Model 8410C/8411A Network Analyzer

1-53. The 8340A is compatible with the HP Model 8410B/C Network Analyzer system. The combination of the Model 8410B/C Network Analyzer, the Model 8411A Frequency Converter, and an appropriate display plug-in forms a phasemeter and a ratiometer for direct phase and amplitude ratio measurements on RF voltages. These measurements can be made on single frequencies and on swept frequencies from 110 MHz to 18 GHz. The Model 8410B/C has an Auto-Frequency range mode which gives it the capability of automatically tracking the 8340A over octave and multi-octave frequency bands. Two interconnections to the 8340A are necessary to ensure that the Model 8410B/C will phase lock properly. The Model 8410B/C Source Control Cable (HP Part Number 08410-60146) connects the Model 8410B/C rear panel SOURCE CONTROL connector to the 8340A rear panel 8410B INTERFACE connector. Additionally, the 8340A rear panel 1V/GHz output connects to the Model 8410B/C rear

panel **FREQ REF INPUT**. The Model 8410B **INTERFACE** connector pins and signals are illustrated in Section II, Installation, in this volume. Additional information on interfacing the 8340A with the 8410 is included in Section III, Operation, in this volume.

1-54. HP Model 8755 Frequency Response Test Set

1-55. The 8340A is directly compatible with the 8755 Frequency Response Test Set for broadband swept scalar measurements. The 8755 provides a front panel 27.8 kHz square wave AM modulation output. This output can be routed directly into the 8340A AM Modulation Input connector. When **[SHIFT][PULSE]** is pressed on the 8340A, the RF **OUTPUT** will then be modulated at 27.8 kHz, thereby providing the correct modulation frequency for the 8755 ac detection scheme. This eliminates the need for an external modulator.

1-56. The 8340A can also sequence alternate sweeps in the 8755C through the use of the **ALT** function. This works in conjunction with the channel switching circuits in the 8755C. This permits Channel 1 on the 8755C to respond only to the 8340A current state and Channel 2 to the alternate state. A single cable (HP Part Number 8120-3174) connects between the 8340A rear panel 8755C **INTERFACE** connector and the 8755C front panel **ALT SWP INTERFACE** connector to provide the necessary signals for channel sequencing. The 8340A rear panel 8755C **INTERFACE** connector pins and signals are illustrated in Section II, Installation, in this volume. Additional information on interfacing the 8340A with the 8755 is included in Section III, Operation, in this volume.

1-57. HP Model 8756A Scalar Network Analyzer

1-58. The Model 8756A Scalar Network Analyzer is a microprocessor-based analyzer capable of making scalar (magnitude only) reflection and transmission measurements at RF and microwave frequencies. The 8756 is completely programmable through HP-IB and can control the 8340A, the HP Model 8350B Sweep Oscillator, or a plotter directly. In addition to the source, a

complete 8756A measurement system requires the use of detectors and/or bridges to the R, A, or B inputs on the front panel.

1-59. Power Meters and Crystal Detectors

1-60. The RF output can be externally leveled using the HP Model 432, HP Model 435, or HP Model 436 Power Meters, or with positive or negative polarity output crystal detectors. Additional information on interfacing the 8340A with power meters and crystal detectors is included in Section III, Operation, in this volume.

1-61. RECOMMENDED TEST EQUIPMENT

1-62. Table 1-2. is a complete list of all required equipment for the tests and adjustments supplied in Section IV, Performance Tests, the Automated Test Procedures, and Section V, Adjustments. Test equipment that is used for automated tests is footnoted in the table for easy reference; some equipment is required only for the automated procedures. Test equipment other than that noted in the table may be substituted if it meets or exceeds the critical specifications indicated in the table.

1-63. Most of the procedures required to verify HP 8340A operation are provided in the (non-automated) test procedures in Section IV, Performance Tests. Frequency Switching Time can only be measured using an automated test and verification of the 8340A RF attenuator performance would be impractical with a manual test. Although a manual test for frequency response is provided, an automated test is available for convenience. The RF attenuator test uses data generated by the frequency response test. The automated frequency response test may be used in lieu of the manual procedure.

1-64. The automated 8340A test programs are for use with an HP 9826A or 9836A Desktop Computer. The test programs are available on two discs. The operating instructions supplied with the discs are also included in the Automated Test Procedures section of this manual. The manual and the test program discs are available by ordering the HP Part Number shown in the Automated Test Procedures section of this volume.

Table 1-1. Model HP 8340A Specifications and Supplemental Performance Characteristics (1 of 15)

| |
|--|
| NOTE |
| <p>Model 8340A Specifications are the performance standards, or limits, against which the instrument may be tested; specifications are shaded in this table. The following Specifications apply for temperatures between 0 and +55°C except where noted. Specifications apply with the PEAK function ON in the CW and MANUAL modes of operation, and with periodic use of AUTO TRACKING CALIBRATION in swept operation.</p> |
| <p>Supplemental Performance Characteristics are not shaded in this table and are intended to provide information useful in applying the instrument by giving typical, but non-warranted, performance parameters. These are denoted as "typical," "nominal," or "approximate."</p> |
| FREQUENCY |
| CW MODE |
| <p>Range: 0.01 to 26.5 GHz</p> <p>Resolution: $n \times 1$ Hz Where N = harmonic multiplication (1 to 4). Refer to Frequency ranges and Bandswitch Points description below.</p> <p>Accuracy: Same as Time Base Accuracy</p> <p>Time Base</p> <p>Frequency: 10 MHz</p> <p>Aging Rate: 1×10^{-9} per day, 2.5×10^{-7} per year after 72-hour warm up if HP 8340A has been disconnected from ac power for less than 24 hours. Aging rate is achieved after 7 to 30 days warm up if HP 8340A has been disconnected from ac power for greater than 24 hours.</p> <p>Temperature Coefficient: Typically $< 1 \times 10^{-11}$ per °C</p> <p>Change due to 10% line voltage change: Typically $< 1 \times 10^{-11}$</p> <p>Accuracy: Overall accuracy of internal time base is a function of time base calibration \pm aging rate \pm temperature effects \pm line effects.</p> <p>Switching Time: < 50 msec (PEAK function off) (Fast Phase Lock Mode reduces typical switching time to < 20 msec.)</p> |
| CENTER FREQUENCY/SWEEP WIDTH MODE (CF/ΔF) |
| <p>Range: 10.00005 MHz to 26.49999995 GHz (center frequency) 100 Hz to 26.49 GHz (sweep width)</p> <p>Resolution: Approximately 0.1% of sweep width (ΔF)</p> <p>Readout Accuracy with respect to sweep out voltage (sweep time > 100 msec): $\Delta \leq n \times 5$ MHz: $\pm 1\%$ of indicated sweep width (ΔF) \pm time base accuracy* $\Delta > n \times 5$ MHz to < 300 MHz: $\pm 2\%$ of indicated sweep width (ΔF) $\Delta \geq 300$ MHz: $\pm 1\%$ of indicated sweep width (ΔF), or ± 50 MHz, whichever is less.</p> <p>Where n = harmonic multiplication number (1 to 4). Refer to Frequency Ranges and Bandswitch Points description below.</p> <p>*Time Base affects Center Frequency accuracy only, not sweep width accuracy.</p> |

Specifications are shaded; Supplemental Performance Characteristics are not.

Table 1-1. Model HP 8340A Specifications and Supplemental Performance Characteristics (2 of 15)

| FREQUENCY (Cont'd) |
|--|
| <p>START/STOP MODE</p> <p>Range Start: 10 MHz to 26 499.9999 MHz Stop: 10.0001 MHz to 26.5 GHz</p> <p>Resolution: Typically, the same as Center Frequency/Sweep Width mode:</p> <p>Readout Accuracy with respect to sweep out voltage (sweep time > 100 msec): Same as Center Frequency/Sweep Width Mode.</p> |
| <p>FREQUENCY MARKERS</p> <p>All 5 markers are independently variable and have the same specifications.</p> <p>Range: 10 MHz to 26.5 GHz</p> <p>Resolution: Approximately 0.1% of sweep width (ΔF)</p> <p>Readout Accuracy (sweep time > 100 msec): Same as CENTER FREQUENCY/SWEEP WIDTH MODE (CF/ΔF), Readout Accuracy specifications. Where n = harmonic multiplication number (1 to 4). Refer to Frequency Ranges and Bandswitch Points Description below.</p> <p>*Time base accuracy is not a factor in MKRΔ Mode.</p> |
| <p>FREQUENCY RANGES AND BANDSWITCH POINTS</p> <p>For bands 0 and 1, the HP 8340A's output is derived from the fundamental frequency of its internal 2.3 to 7.0 GHz YIG-tuned oscillator (n = 1). For bands 2,3, and 4, the output is derived from the 2nd, 3rd, or 4th harmonic of the oscillator (n = 2, 3 or 4).</p> <p>Bandswitch points in CW Mode (only) always occur at the following points:</p> <ul style="list-style-type: none"> Band 0 to 1: 2.3 GHz Band 1 to 2: 7.0 GHz Band 2 to 3: 13.5 GHz Band 3 to 4: 20.0 GHz <p>Bandswitch points in each of the swept modes (CF/ΔF, START/STOP) and the MANUAL SWEEP mode normally occur at the following points (with the exception listed below):</p> <ul style="list-style-type: none"> Band 0 to 1: 2.4 GHz Band 1 to 2: 7.0 GHz Band 2 to 3: 13.5 GHz Band 3 to 4: 20.0 GHz <p>The swept mode bandswitch points are illustrated in Figure 1.</p> |

Specifications are shaded; Supplemental Performance Characteristics are not.

Table 1-1. Model HP 8340A Specifications and Supplemental Performance Characteristics (3 of 15)

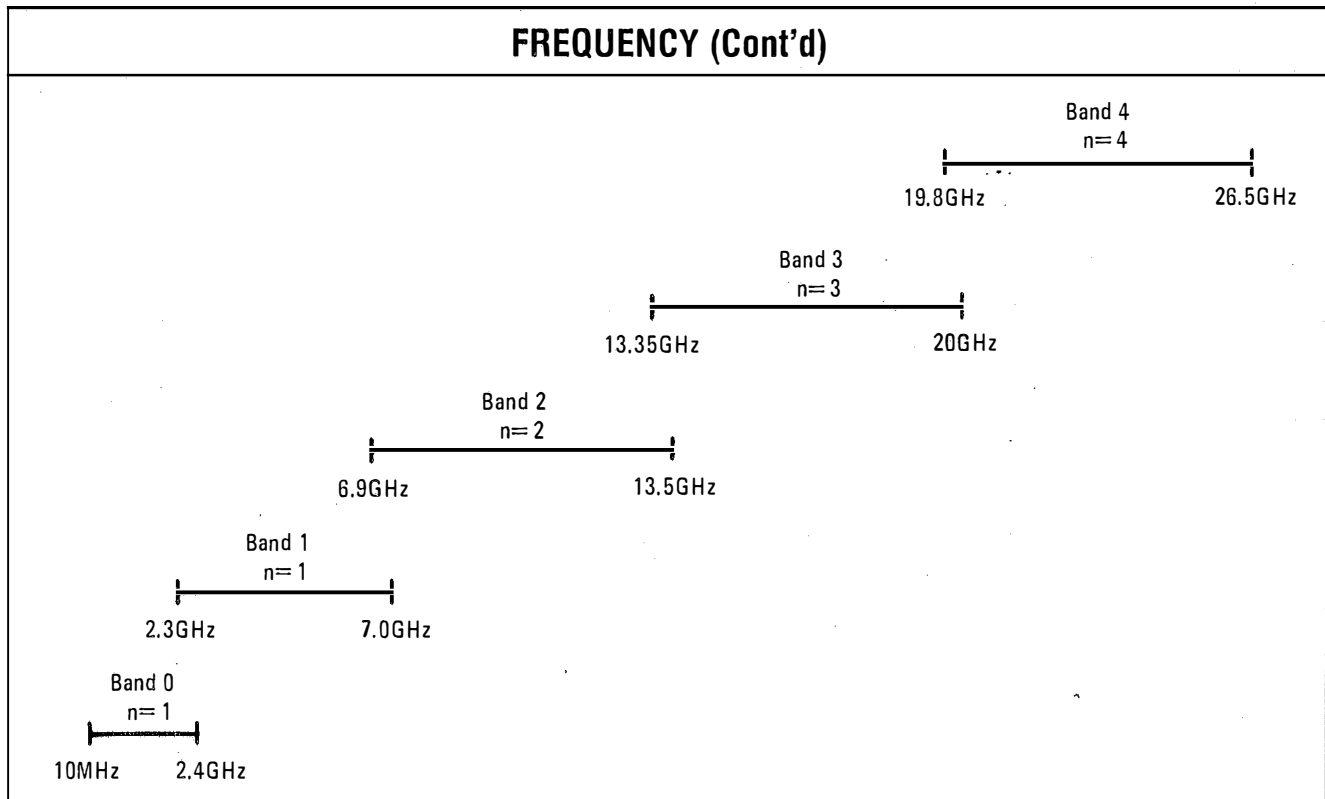

Figure 1. Frequency Ranges and Bandswitch Points in Swept Modes

Note that the bands overlap. However, any sweep will be executed with the minimum number of bandswitch points. If the start frequency is above the lower limit for a given band, the sweep will start in that band and not the next lower one. If the stop frequency exceeds the upper limit of a given band by an amount greater than $0.004 \times \Delta F$, a bandswitch will occur at that band's upper limit.

SPECTRAL PURITY

(Spectral Purity specifications apply for CW mode and all swept modes, unless otherwise stated.)

| SPURIOUS SIGNALS (Expressed in dB relative to the carrier level (dBc) at ALC level of 0 dBm) | Bands and Approximate Frequency Ranges (GHz) (See Frequency Ranges and Bandswitch Points for complete description) | | | | |
|---|---|-----------------------|------------------------|-------------------------|------------------------|
| | Band 0 0.01 to <2.3 | Band 1 2.3 to <7.0 | Band 2 7.0 to <13.5 | Band 3 13.5 to <20.0 | Band 4 20.0 to 26.5 |
| Harmonics (up to 26.5 GHz) | < -35 | < -35 | < -35 | < -35 | < -35 |
| Subharmonics and multiples thereof (up to 26.5 GHz) | — | — | < -25 | < -25 | < -20 |
| Non-harmonically related spurious (CW and Manual Sweep mode only) | < -50 | < -70 | < -64 | < -60 | < -58 |

Specifications are shaded; Supplemental Performance Characteristics are not.

Table 1-1. Model HP 8340A Specifications and Supplemental Performance Characteristics (4 of 15)

| SPECTRAL PURITY (Cont'd) | | | | | |
|---|---------------------------------|------------------------------|-------------------------------|---------------------------------|--------------------------------|
| SPURIOUS SIGNALS (Cont'd) Power line related and spurious due to fan rotation within 5 Hz below line frequency, and multiples thereof | | | | | |
| (CW mode only, all power levels) | Band 0 0.0001 to <2.3 | Band 1 2.3 to <7.0 | Band 2 7.0 to <13.5 | Band 3 13.5 to <20.00 | Band 4 20.00 to 26.5 |
| Offset < 300 Hz from carrier | < -50 | < -50 | < -44 | < -40 | < -38 |
| Offset 300 Hz to 1 kHz from carrier | < -60 | < -60 | < -54 | < -50 | < -48 |
| Offset > 1 kHz from carrier | < -65 | < -65 | < -59 | < -55 | < -53 |
| SINGLE-SIDEBAND PHASE NOISE (dBc/1 Hz BW, CW Mode, all power levels) | | | | | |
| STANDARD INSTRUMENT | | | | | |
| Offset 30 Hz from carrier | < -64 | < -64 | < -58 | < -54 | < -52 |
| Offset 100 Hz from carrier | < -70 | < -70 | < -64 | < -60 | < -58 |
| Offset 1 kHz from carrier | < -78 | < -78 | < -72 | < -68 | < -66 |
| Offset 10 kHz from carrier | < -86 | < -86 | < -80 | < -76 | < -74 |
| Offset 100 kHz from carrier | < -107 | < -107 | < -101 | < -97 | < -95 |
| OPTION 007, Relaxed Phase Noise Specifications | | | | | |
| Offset 100 Hz from carrier | < -67 | < -67 | < -61 | < -57 | < -55 |
| Offset 1 kHz from carrier | < -75 | < -75 | < -69 | < -65 | < -63 |
| Offset 10 kHz from carrier | < -83 | < -83 | < -77 | < -73 | < -71 |
| Offset 100 kHz from carrier | < -107 | < -107 | < -101 | < -97 | < -95 |
| TYPICAL FREQUENCY STABILITY, 50 Hz - 15 kHz post detection bandwidth | | | | | |
| Typical Residual FM in CW mode: < n x 60 Hz rms | | | | | |
| Typical Residual FM in Swept Mode: | | | | | |
| $\Delta F > n \times 5 \text{ MHz: } < n \times 25 \text{ kHz rms}$ | | | | | |
| $\Delta F \leq n \times 5 \text{ MHz: Same as CW mode}$ | | | | | |
| Where n = harmonic multiplication number (1 to 4). Refer to Frequency Ranges and Bandswitch Points description above. | | | | | |

Specifications are shaded; Supplemental Performance Characteristics are not.

Table 1-1. Model HP 8340A Specifications and Supplemental Performance Characteristics (5 of 15)

| RF OUTPUT | | | | | | |
|--|--|--|-----------------------------|-------------------------|------------------------------------|---------------------|
| MAXIMUM LEVELED POWER (0°C to +35°C) ¹ | Bands and Approximate Frequency Ranges (GHz) (see Frequency Ranges and Bandswitch Points for complete description) | | | | | |
| | Band 0 | Band 1 | Band 2 | Band 3 | Band 4 | |
| | 0.01 to < 2.3 | 2.3 to <7.0 | 7.0 to <13.5 | 13.5 to <20.0 | 20.0 to <23.0 | 23.0 to 26.5 |
| STANDARD INSTRUMENT | +10.0 dBm | +12.0 dBm | +10.0 dBm | +9.0 dBm | +3.0 dBm | +1.0 dBm |
| OPTION 001 (F.P. Out w/o Atten.) | +10.0 dBm | +13.0 dBm | +12.0 dBm | +11.0 dBm | +6.0 dBm | +4.0 dBm |
| OPTION 004 (R.P. Out w/Atten.) | +10.0 dBm | +11.0 dBm | +9.0 dBm | +7.0 dBm | +1.0 dBm | -1.0 dBm |
| OPTION 005 (R.P. Out w/o Atten.) | +10.0 dBm | +12.0 dBm | +11.0 dBm | +9.0 dBm | +4.0 dBm | +2.0 dBm |
| MINIMUM SETTABLE POWER | | | | | | |
| STANDARD: -110 dBm | | | | | | |
| OPTION 001 (F.P. Out w/o Atten.) and 005 (R.P. Out w/o Atten.): -20 dBm | | | | | | |
| RF OFF | | | | | | |
| When the RF key is turned OFF, the POWER dBm display will read OFF and a 0 dBm signal will typically be reduced to a level < -100 dBm. | | | | | | |
| OUTPUT POWER RESOLUTION | | | | | | |
| "ENTRY DISPLAY": 0.05 dB | | | "POWER dBm" Display: 0.1 dB | | | |
| OUTPUT POWER ACCURACY² | Bands and Approximate Frequency Ranges (GHz) see Frequency Ranges and Bandswitch Points for complete description) | | | | | |
| | Band 0 0.01 to <2.3 | Bands 1-3 2.3 to <20 | | | Band 4 20 to 26.5 | |
| STANDARD INSTRUMENT | | | | | | |
| +18 to +10 dBm ⁴ | - | ± 1.8 dB | | | ± 2.3 dB | |
| +10 to -9.95 dBm | ± 0.9 dB | ± 1.5 dB | | | ± 2.0 dB | |
| -10 to -19.95 dBm | ± 1.2 dB | ± 2.0 dB | | | ± 2.5 dB | |
| -20 to -49.95 dBm | ± 1.5 dB | ± 2.3 dB | | | ± 2.8 dB | |
| -50 to -79.95 dBm | ± 1.8 dB | ± 2.6 dB | | | ± 3.1 dB | |
| -80 to -100 dBm | ± 2.1 dB | ± 2.9 dB | | | ± 3.4 dB | |
| -100 to -110 dBm | ± 2.9 dB ³ | ± 3.7 dB ³ | | | ± 4.2 dB ³ | |
| OPTION 004 (Rear Panel Output with Attenuator) | | | | | | |
| +18 to +10 dBm ⁴ | - | ± 2.0 dB | | | ± 2.5 dB | |
| +10 to -11.95 dBm | ± 1.0 dB | ± 1.7 dB | | | ± 2.2 dB | |
| -12 to -21.95 dBm | ± 1.3 dB | ± 2.2 dB | | | ± 2.7 dB | |
| -22 to -51.95 dBm | ± 1.6 dB | ± 2.5 dB | | | ± 3.0 dB | |
| -52 to -81.95 dBm | ± 1.9 dB | ± 2.8 dB | | | ± 3.3 dB | |
| -82 to -100 dBm | ± 2.2 dB | ± 3.1 dB | | | ± 3.6 dB | |
| -100 to -110 dBm | ± 3.0 dB ³ | ± 3.9 dB ³ | | | ± 4.4 dB ³ | |

Specifications are shaded; Supplemental Performance Characteristics are not

Table 1-1. Model HP 8340A Specifications and Supplemental Performance Characteristics (6 of 15)

| RF OUTPUT (Cont'd) | | | |
|--|--|---|---|
| OUTPUT POWER ACCURACY (Cont'd) | Band 0 0.01 to <2.3 | Bands 1-3 2.3 to <20 | Band 4 20 to 26.5 |
| OPTION 001 (Front Panel Output w/o Attenuator) +18 to +10 dBm ⁴ +10 to -10 dBm -10 to -20 dBm | - ± 0.9 dB ± 1.7 dB | ± 1.6 dB ± 1.3 dB ± 2.1 dB | ± 2.0 dB ± 1.7 dB ± 2.5 dB |
| OPTION 005 (Rear Panel Output w/o Attenuator) +18 to +10 dBm ⁴ +10 to -10 dBm -10 to -20 dBm | - ± 1.0 dB ± 1.8 dB | ± 1.8 dB ± 1.5 dB ± 2.3 dB | ± 2.2 dB ± 1.9 dB ± 2.7 dB |
| FLATNESS (Internally leveled) | | | |
| STANDARD INSTRUMENT +18 to +10 dBm ⁴ +10 to -9.95 dBm -10 to -19.95 dBm -20 to -49.95 dBm -50 to -79.95 dBm -80 to -100 dBm -100 to -110 dBm | - ± 0.6 dB ± 0.9 dB ± 1.2 dB ± 1.4 dB ± 1.7 dB ± 1.9 dB ³ | ± 1.2 dB ± 1.1 dB ± 1.6 dB ± 1.9 dB ± 2.2 dB ± 2.5 dB ± 3.1 dB ³ | ± 1.7 dB ± 1.6 dB ± 2.1 dB ± 2.4 dB ± 2.7 dB ± 3.0 dB ± 3.6 dB ³ |
| OPTION 004 (Rear Panel Output with Attenuator) +18 to +10 dBm ⁴ +10 to -11.95 dBm -12 to -21.95 dBm -22 to -51.95 dBm -52 to -81.95 dBm -82 to -100 dBm -100 to -110 dBm | - ± 0.7 dB ± 1.0 dB ± 1.3 dB ± 1.5 dB ± 1.8 dB ± 2.0 dB ³ | ± 1.4 dB ± 1.3 dB ± 1.8 dB ± 2.1 dB ± 2.4 dB ± 2.7 dB ± 3.3 dB ³ | ± 1.9 dB ± 1.8 dB ± 2.3 dB ± 2.6 dB ± 2.9 dB ± 3.2 dB ± 3.8 dB ³ |
| OPTION 001 (Front Panel Output w/o Attenuator) +18 to +10 dBm ⁴ +10 to -10 dBm -10 to -20 dBm | - ± 0.6 dB ± 0.8 dB | ± 1.0 dB ± 0.9 dB ± 1.5 dB | ± 1.4 dB ± 1.3 dB ± 1.9 dB |
| OPTION 005 (Rear Panel Output w/o Attenuator) +18 to +10 dBm ⁴ +10 to -10 dBm -10 to -20 dBm | - ± 0.7 dB ± 0.9 dB | ± 1.2 dB ± 1.1 dB ± 1.7 dB | ± 1.6 dB ± 1.5 dB ± 2.1 dB |

Specifications are shaded; Supplemental Performance Characteristics are not.

Table 1-1. Model HP 8340A Specifications and Supplemental Performance Characteristics (7 of 15)

RF OUTPUT (Cont'd)

TYPICAL ALC INCREMENTAL ACCURACY

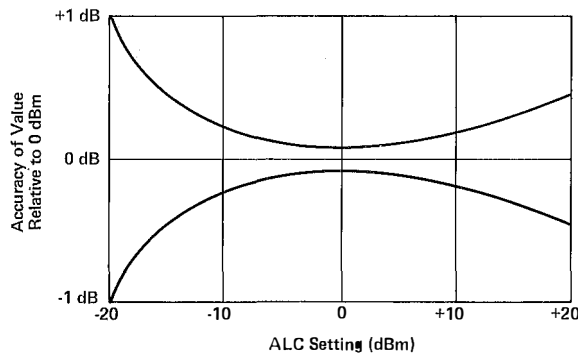

Figure 2. Typical ALC Incremental Accuracy

In normal operation, the ALC does not operate below -9.95 dBm because the 8340A automatically increments the step attenuator at that point. However, when the ALC and step attenuator are independently controlled (DECOUPLED mode), the ALC may be operated over its full $+20$ dBm to -20 dBm range. Refer to Section III, Operation for a more detailed description.

RF OUTPUT CONNECTOR

Output Impedance: Nominally 50 Ohms

Source SWR (Internally leveled only):
 0.1 to <2.3 GHz: Typically $<1.3:1$
 2.3 to <18.0 GHz: Typically $<1.6:1$
 18.0 to 26.5 GHz: Typically $<2.0:1$

STABILITY WITH TEMPERATURE: Typically ± 0.01 dB/ $^{\circ}$ C

OUTPUT LEVEL SWITCHING TIME:

Typically <10 ms to be within 0.1 dB of final value with no attenuator range change (internally leveled only).

POWER SWEEP

Range:
 Displayed: 0 to 40 dB/sweep
 Actual: At least 10 dB at any given frequency (at least 20 dB in DECOUPLED mode; see Figure 3 below.)

Resolution: 0.05 dB/sweep

Accuracy:
 Starting Power Level: Same as Output Power Accuracy
 Power Sweep Width and Linearity: See Figure 2.

Specifications are shaded; Supplemental Performance Characteristics are not.

Table 1-1. Model HP 8340A Specifications and Supplemental Performance Characteristics (8 of 15)

| RF OUTPUT (Cont'd) | |
|---|--|
| <p style="text-align: center;">(a) Normal (Coupled)</p> | <p style="text-align: center;">(b) (Decoupled)</p> |
| <p><i>Figure 3. Power Sweep Range</i></p> <p>In normal operation (a), the ALC does not operate below -9.95 dBm (see Figure 2), and so the maximum power sweep range is the difference of -9.95 dBm and the maximum leveled power available at the frequency of interest (specified leveled power shown in diagram). In the DECOUPLED mode (b), the power sweep range is extended because the ALC can operate down to -20 dBm.</p> | |
| <p>SLOPE COMPENSATION</p> <p style="display: flex; justify-content: space-between;">Calibrated Range: 0 to 1.5 dB/GHzResolution: 0.001 dB/GHz</p> | |
| <p>EXTERNAL LEVELING</p> <p>XTAL: Allows the 8340A to be externally leveled by crystal detectors of positive or negative polarity.</p> <p>METER: Allows power meter leveling with any HP power meter.</p> <p>Range (XTAL or METER): 500 microvolts (-66 dBV) to 2.0 volts ($+6$ dBV)</p> <p>Accuracy of voltage at EXT INPUT connector relative to the displayed level (leveling voltage is shown in ENTRY DISPLAY in dBV): ± 0.5 dB ± 0.2 mV</p> <p>Loop Bandwidth:</p> <p style="display: flex; justify-content: space-around;">XTAL Mode: Nominally 30 kHzMETER Mode: Nominally 0.7 Hz</p> <p>Input Impedance: Nominally 1 M Ohm.</p> | |

Specifications are shaded; Supplemental Performance Characteristics are not.

Table 1-1. Model HP 8340A Specifications and Supplemental Performance Characteristics (9 of 15)

| PULSE MODULATION | | | |
|---|--------------|---------------|---------------|
| (CW mode, and all specifications are typical for frequencies < 400 MHz) | | | |
| ON/OFF RATIO: >80 dB | | | |
| RISE (T_R) AND FALL (T_F) TIMES: ≤25 nanoseconds | | | |
| MINIMUM INTERNALLY LEVELED RF PULSE WIDTH (T_{RF}): 100 nanoseconds | | | |
| MINIMUM UNLEVELED RF PULSE WIDTH: Typically 25 nanoseconds | | | |
| PULSE REPETITION FREQUENCY (PRF) | | | |
| Non-leveled operation (SHIFT METER): Typically dc to 20 MHz. | | | |
| Internally leveled operation: 100 Hz to 5 MHz (typically 100 Hz to 500 kHz for RF frequencies < 400 MHz). | | | |
| If SHIFT AM is pressed (see Settling Time), minimum PRF must be ≥ 1 kHz rather than 100 Hz. | | | |
| MAXIMUM PEAK POWER: Same as specified maximum leveled power. (See RF OUTPUT.) | | | |
| ACCURACY OF INTERNALLY LEVELED RF PULSE V_p (relative to CW mode level): | | | |
| (Note that the ALC attempts to hold pulse amplitude to same level as leveled CW signal.) | | | |
| Bands and Approximate Frequency Ranges (GHz) (see Frequency Ranges and Bandswitch Points for complete description). | | | |
| Pulse Width | Band 0 | | Bands 1–4 |
| | 0.01 to 0.4 | 0.4 to <2.3 | 2.3 to 26.5 |
| 100 to <200 ns | — | +3/–0.3 dB* | +1.5/–0.3 dB* |
| 200 to <500 ns | — | +1.5/–0.3 dB* | ± 0.3 dB |
| ≥500 ns | — | ± 0.3 dB | ± 0.3 dB |
| 1 to <2 μs | +3/–0.3 dB | — | — |
| 2 to <5 μs | +1.5/–0.3 dB | — | — |
| ≥5 μs | ± 0.3 dB | — | — |
| * +15 to +55°C. Duty Cycle must be > 0.01 %. | | | |

Specifications are shaded; Supplemental Performance Characteristics are not.

Table 1-1. Model 8340A Specifications and Supplemental Performance Characteristics (10 of 15)

| PULSE MODULATION (Cont'd) | | |
|--|---|--|
| SIMULTANEOUS AM AND PULSE | | |
| AM BANDWIDTH AT 30% DEPTH | | |
| DC coupled, typical 3 dB point: | | |
| Mode | Internally Leveled | Unleveled (Shift Meter^{***}) |
| Normal | PRF/20 ^{**} , to a maximum of 5 kHz | 5 kHz |
| SHIFT AM* | PRF/10 ^{**} , to a maximum of 100 kHz | 100kHz |
| SETTLING TIME TO A STEP INPUT, 10%-90%, TYP: | | |
| Normal | The greater of: 70 μ sec, or the time for the number of pulses indicated by the solid line below. | 70 μ sec |
| SHIFT AM* | The greater of: 3.5 μ sec, or the time for the number of pulses indicated by the dashed line below. | 3.5 μ sec |
| <p style="text-align: center;">* [SHIFT] [AM] increases AM bandwidth in pulse mode, but also causes slight degradation of the pulse envelope and raises the minimum PRF to 1 kHz. ** PRF= PULSE REPETITION FREQUENCY. *** [SHIFT] [METER] is an unleveled operating mode, power is controllable, but not flat over frequency. AM bandwidth in this mode is independent of pulse rate and width. See Section I.</p> | | |
| OVERSHOOT, RINGING (V_{OR}/V_P): <15% typically | | |
| PULSE WIDTH COMPRESSION ($T_V - T_{RF}$): ± 5 nanoseconds typically | | |
| DELAY TIME (T_D): 50 nanoseconds typically | | |
| VIDEO FEEDTHROUGH (V_F/V_P): | | |
| 0.01 to < 0.4 GHz (Band 0): < 100% typically | | |
| 0.4 to < 2.3 GHz (Band 0): $\leq 5\%$ (for output power levels $\leq +8$ dBm) | | |
| 2.3 to 26.5 GHz (Bands 1-4): $\leq 0.2\%$ | | |
| SIDEBANDS (caused by a pulse input when PULSE is OFF): | | |
| Typically -50 dBc with a 30 kHz squarewave input from 0.01 to 7.0 GHz. | | |

Specifications are shaded; Supplemental Performance Characteristics are not.

Table 1-1. Model HP 8340A Specifications and Supplemental Performance Characteristics (11 of 15)

PULSE MODULATION (Cont'd)

PULSE INPUT CONNECTOR:

TTL compatible. (Open circuit is TTL high level and keeps RF on.) Damage level is +12 Vdc, -20 Vdc. Refer to Section III, Operation, for input circuit diagram.

PULSE DEFINITIONS:

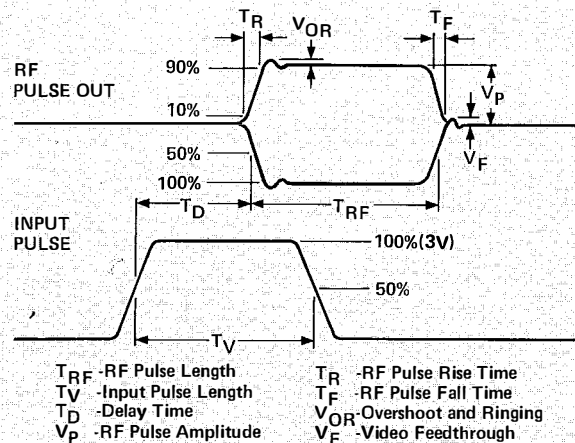

Figure 4. Pulse Definitions

AMPLITUDE MODULATION

(The following specifications apply when the 8340A is internally leveled, for waveforms whose envelope peak is at least 1 dB below maximum specified power. Unless noted, pulse modulation must be OFF; however, the 8340A is capable of simultaneous amplitude and pulse modulation. See Section III, Operation.)

AM DEPTH: 0 to 90%

AM SENSITIVITY (at 1 kHz rate and 30% Depth):

100%/V \pm 5% RF amplitude is linearly controlled by varying AM input between 0 and ± 1 Volt.

PULSE ON: 100%/Volt typically for rates less than 0.1/Settling Time.

AM BANDWIDTH (relative to 1 kHz rate at 30% Depth):

DC coupled, 3 dB point \geq 100 kHz

PULSE on: DC coupled, 3 dB point \geq PRF/20, typically.

(Refer to Pulse Modulation specs for a more complete description.)

AM FREQUENCY RESPONSE (FLATNESS) (relative to a 1 kHz rate at 30% depth, DC to 10 kHz): ± 0.20 dB

DISTORTION: Typical distortion values are given in Figure 5.

Specifications are shaded; Supplemental Performance Characteristics are not.

Table 1-1. Model HP 8340A Specifications and Supplemental Performance Characteristics (12 of 15)

| AMPLITUDE MODULATION (Cont'd) | |
|--|--|
| | |
| <p><i>Figure 5. Typical 8340A AM Distortion for Various Modulation Rates and Depths</i></p> | |
| <p>INCIDENTAL PHASE MODULATION (in peak radians) (Rates ≤10 kHz, 30% Depth): <0.4 typically</p> | |
| <p>INCIDENTAL FM: Incidental Phase Modulation x Modulation Frequency</p> | |
| <p>AM INPUT IMPEDANCE: Nominally 600 Ohms.</p> | |
| SWEEP TIME | |
| <p>RANGE: 10 milliseconds to 200 seconds forward sweep times Fastest possible sweep typically cycles once every 40 ms; fastest possible full band sweep typically cycles once every 150 ms.</p> | |
| <p>RESOLUTION: Approximately 0.1% of current sweep time value.</p> | |
| <p>ACCURACY: ± 5% (sweeptimes ≤50 seconds)</p> | |
| INPUTS | |
| <p>PULSE MODULATION INPUT Front panel BNC female input connector. TTL compatible (open circuit is TTL high level and keeps RF on). Damage level is +12 Vdc, -20 Vdc.</p> | |
| <p>AM MODULATION INPUT Front panel BNC female input connector. Nominal input impedance is 600 Ohms.</p> | |
| <p>LEVELING EXT INPUT Front panel BNC female input connector. Used for power meter leveling or crystal detector leveling. Input impedance in XTAL or METER modes is nominally 1 MOhm. Refer to EXTERNAL LEVELING specifications.</p> | |
| <p>FREQUENCY STANDARD EXT Rear panel BNC female connector. Accepts 5 or 10 MHz signal from internal or external timebase. A BNC jumper connects this input to the 8340's FREQUENCY STANDARD INT output for operation from 8340A's internal timebase. External signal input must be 5 MHz ±50 Hz or 10 MHz ±100 Hz, 0 to +10 dBm. Nominal input impedance is 50 ohms.</p> | |

Specifications are shaded; Supplemental Performance Characteristics are not.

Table 1-1. HP Model 8340A Specifications and Supplemental Performance Characteristics (13 of 15)

| INPUTS (Cont'd) |
|---|
| <p>EXT TRIGGER INPUT Rear panel BNC female connector. Triggers single sweep. Trigger signal must be > 2 Vdc (10 Vdc max) and wider than 0.5 microseconds. Nominal input impedance is 2 kOhms.</p> <p>STOP SWP IN/OUT: Rear panel BNC female connector. TTL high while sweeping, stops sweep when grounded externally. TTL low when 8340A stops sweep.</p> <p>8755C INTERFACE Rear panel. Connects via cable (HP Part No. 8120-3174) to HP 8755C Scalar Network Analyzer to provide Alternate Sweep function.</p> <p>8410B INTERFACE Rear panel 25-pin D-type connector. Permits multi-octave operation of HP 8410B/C Network Analyzer with 8340A, via interface cable (HP Part No. 08410-60146). Also provides duplicates of these functions: Ext Trigger Input, Mute Output, Penlift Output, Neg Blank, and Z-Axis Blank/Mkrs. Also provides an input for a switch closure to execute the UP key function.</p> |
| OUTPUTS |
| <p>RF OUTPUT Front panel Precision APC-3.5 male connector. Frequency output range is 10 MHz to 26.5 GHz. Nominal output impedance is 50 Ohms. SWR is shown in RF OUTPUT characteristics.</p> <p>SWEEP OUTPUT Front and rear panel BNC female connectors. Supplies a voltage proportional to the sweep that ranges from approximately 0 Vdc (at start of sweep) to approximately +10 Vdc (at end of sweep), regardless of sweep width. In CW mode, the dc voltage is proportional to percentage of full 10 MHz to 26.5 GHz range.</p> <p>1 V/GHz (19V Max) Rear panel BNC female connector. Outputs a voltage proportional to output frequency at 1V/GHz, up to a maximum of 19 Vdc. Nominal load impedance should be ≥ 4 KOhms. Accuracy of 1V/GHz is $\pm 1\% \pm 2$mV.</p> <p>10 MHz REF OUTPUT Rear panel BNC female connector. Output power level is nominally 0 dBm. Output impedance is nominally 50 Ohms.</p> <p>FREQUENCY STANDARD INT Rear panel BNC connector. Output frequency 10 MHz, output power nominally 3 dBm, 50 Ohm nominal output impedance. Jumpered to FREQUENCY STANDARD EXT for operation from 8340A's internal timebase.</p> <p>MUTE OUTPUT Rear panel BNC female connector. Mutes servo motor of X-Y recorder when the 8340A crosses a band switchpoint.</p> <p>PENLIFT OUTPUT J13 For operation with X-Y recorders. PENLIFT DISABLES AN X-Y recorder's ability to lower its pen during sweep retrace. If [SHIFT] [LINE] is pressed on the front panel, PENLIFT will also disable the pen during forward sweep band switchpoints. Because of X-Y recorder limitations PENLIFT will always disable the X-Y recorder's pen at sweep times under 5 seconds. PENLIFT enables pen operation by providing a current path to ground for the X-Y recorder's pen solenoid. The voltage at the PENLIFT output in this state will be approximately 0 Vdc. Circuit impedance in this state is approximately .5 Ohms. PENLIFT disables pen operation by not providing a current path to ground for the X-Y recorder's pen solenoid. The voltage on the PENLIFT output will be equal to the X-Y recorder's pen solenoid supply voltage. Circuit impedance in this state is very high.</p> |

Specifications are shaded; Supplemental Performance Characteristics are not.

Table 1-1. Model HP 8340A Specifications and Supplemental Performance Characteristics (14 of 15)

| OUTPUTS (Cont'd) |
|---|
| <p>NEG BLANK Rear panel BNC female connector. Supplies negative rectangular pulse (approximately -5 Vdc into 2 kOhm load) during the retrace and band switchpoints of the RF output.</p> <p>Z-AXIS BLANK/MKRS Rear panel BNC female connector. Supplies positive rectangular pulse (approximately $+5$ Vdc into 2 kOhms) during the retrace and band switchpoints of the RF output. Also, supplies a -5 Vdc pulse when the RF is coincident with a marker frequency (intensity markers only).</p> <p>AUX OUT Rear panel Type-N female connector. Provides a 2.3 to 7.0 GHz fundamental oscillator output, nominally 0 dBm and 50 Ohm output impedance.</p> <p style="text-align: center;">NOTE For further information refer to the Front/Rear Panel functional group in Section VIII.</p> |
| REMOTE OPERATION |
| All functions (except line power) may be programmed via the Hewlett-Packard Interface Bus (HP-IB). Detailed Remote operation information is included in Section III, Operation. |
| GENERAL |
| <p>ENVIRONMENTAL</p> <p>Temperature: Operation at 0 to $+55^{\circ}\text{C}$, except as noted in electrical specifications.</p> <p>Humidity: Passes 5 day cycling, $+40^{\circ}\text{C}$, 95% relative humidity.</p> <p>EMI: Conducted and radiated interference is within the requirements of CE03 and RE02 (relaxed by 10 dB) of MIL STD 461A, and within the requirements of VDE 0871/1978, Level B and CISPR publication 11 (1975).</p> |
| <p>WARM-UP TIME</p> <p>Operation: Requires 30-minute warmup from cold start, 0 to $+55^{\circ}\text{C}$. Internal temperature equilibrium is reached after 2-hour warmup at stable outside temperature.</p> <p>Frequency Reference: Reference time base is kept at operating temperature in STANDBY mode with the instrument connected to the ac power. For instruments disconnected from ac power for less than 24 hours, the aging rate is $<1 \times 10^{-9}/\text{day}$ after a 72-hour warmup.</p> |
| <p>POWER REQUIREMENTS</p> <p>Standard Instrument:</p> <p>47.5 to 66 Hz; 100, 120, 220, or 240 volts ($\pm 10\%$); 500 VA maximum (40 VA in STANDBY).</p> <p>Option 003, 400 Hz operation:</p> <p>360 to 440 Hz, 100 or 120 volts ($\pm 10\%$)</p> <p>Operating Temperature Range: 0 to $+55^{\circ}\text{C}$</p> |

Specifications are shaded; Supplemental Performance Characteristics are not.

Table 1-1. Model HP 8340A Specifications and Supplemental Performance Characteristics (15 of 15)

| GENERAL (Cont'd) | |
|--|--|
| WEIGHT | |
| Net Weight: 34 kg (75 lb) | |
| Shipping Weight: 52 kg (112 lb) | |
| DIMENSIONS | |
| <p>The drawing shows three views of the instrument: a top view, a rear view, and a side view. The top view is a square with a handle on the left side. The rear view shows a rectangular shape with a width of 425.5 mm (16.75 in) and a height of 188 mm (7.4 in). The side view shows a rectangular shape with a length of 609.6 mm (24.0 in) and a height of 188 mm (7.4 in).</p> | |
| NOTES | |
| <ol style="list-style-type: none"> 1. Maximum leveled power from 35°C to 55°C will typically be degraded from these specifications by no more than 2 dB. 2. Internally leveled, AM off. The POWER dBm display monitors the actual output power, giving accurate readings when unlevelled, externally leveled, or when amplitude modulating with a signal that has a dc component. In these modes, the accuracy typically degrades by ± 0.1 dB over the tabulated values. The ENTRY DISPLAY shows the desired power level, or the desired external detector output voltage, exclusive of modulation. 3. Typical. 4. The ALC loop typically operates up to +20 dBm to enhance usability at those frequencies where leveled power greater than the maximum specified is available. | |

Specifications are shaded; Supplemental Performance Characteristics are not.

Table 1-2. Recommended Test Equipment (1 of 5)

| Instrument | Critical Specifications | Recommended Model | Use ¹ |
|---|--|----------------------|------------------|
| Signature Multimeter | Clock Frequency: ≥ 20 MHz | HP 5005A | T |
| Oscilloscope | Dual Channel Bandwidth: dc to 100 MHz Vertical Sensitivity: ≤ 5 mV/Div Horizontal Sensitivity: 50 ns/Div 10 Magnifier External Sweep Capability 50 Ohm Vertical Input | HP 1741A | P,A,T |
| Oscilloscope Probe | 10:1 Divider Probe | HP 10004D | T,A |
| Digital Voltmeter (DVM) | Range: -50 to $+50$ Vdc Accuracy: $\pm 0.01\%$ Input Impedance: ≥ 10 MOhms | HP 3455 | AP,AT,A,T |
| Power Meter | Power Range: 1μ W to 100 mW Accuracy: ± 0.02 dB | HP 436A | P,AT,A,T |
| Power Sensors | Frequency Range: 10 to 50 MHz Power Range: 1μ W to 100 mW | HP 8481A | P,AT,A,T |
| | Frequency Range: 50 MHz to 26.5 GHz Power Range: 1μ W to 100 mW | HP 8485A | P,AT,A,T |
| Frequency Counter | Frequency Range: 10 MHz to 26.5 GHz Input Impedance: 50 Ohms Frequency Accuracy: Time Base Accuracy ± 1 count | HP 5343A | P,A,T |
| Universal Counter | Time Interval Range: 100 ns to 200 s | HP 5316A | P,AT,T |
| Spectrum Analyzers | Frequency Range: 0.01 to 22 GHz Must have External Time Base Input Center Frequency Accuracy in 0 Hz Span: Same as Time Base Accuracy Minimum Resolution Bandwidth: ≤ 300 Hz Residual FM: < 100 Hz Log Fidelity: ≤ 1 dB Must have Video Output | HP 8566A | P,A,T |
| | Frequency Range: 20 Hz to 40 MHz Resolution Bandwidth: ≤ 3 Hz | HP 3585A | P,AT,T |
| Frequency Standard | Frequency: 10 MHz Stability: $> 1 \times 10^{-10}$ /yr | HP 5061A | P,A |
| Synthesized Sweeper (used as Local Oscillator in P ¹ and A ¹ , and Sweep Generator in A ¹) | Frequency Range: 10 MHz to 26.5 GHz Must have External Time Base Input Frequency Accuracy: Same as Time Base Accuracy RF Power Output: $\geq +6$ dBm ³ | HP 8340A Opt. 001 | P,AT,A |

Table 1-2. Recommended Test Equipment (2 of 5)

| Instrument | Critical Specifications | Recommended Model | Use ¹ |
|--------------------------------------|---|--|------------------------|
| Signal Generator | Frequency: 300 to 400 MHz RF Output Power: ≥ 0 dBm Settability: to within ± 50 kHz | HP 8654A (or HP 8340A) | A |
| Desktop Computer | No Substitute (Used only for HP-IB Operation Verification; HP 9826A/9836A can be used in place of HP 85F) (Includes HP 83936A ROM Drawer, HP 82937A HP-IB Interface, and I/O ROM HP Part No. 00085-15003.) No Substitute (must have 512K memory) | HP 85F HP 9826A/ 9836A | HP-IB HP-IB, AT |
| Plotter/Printer ROM | For HP 85F, no substitute. | HP Part No. 00085-15002 | HP-IB |
| Printer | Must have graphics capability | HP 2673A | AT |
| Automated Test Procedures Software | No Substitute (Includes two programmed discs with documentation) | HP Part No. 08340-10009 | AT |
| Modulation Analyzer | No Substitute | HP 8901A | P |
| Pulse Generator | Pulse Width: ≤ 100 nS Rise Time: ≤ 10 nS Frequency: 20 Hz to 50 kHz | HP 8012B | P,A,T |
| Function Generator | Sinewave Amplitude: ≥ 1 Vrms Sinewave Frequency: dc to 100 kHz | HP 3325A | P,A,T |
| Amplifier | Frequency Range: 100 kHz to 1.3 GHz Gain: >20 dB | HP 8447F | P |
| Frequency Response Test Set/Detector | Frequency Range: 10 MHz to 26.5 GHz Connector: APC-3.5 | HP 8755C/ HP 11664B | A |
| Storage Normalizer | Compatible with HP 8755C | HP 8750A | A |
| Power Supply | 0 to 50 Vdc Voltage Drift (in 1 Hour): $\leq 0.1\% + 2.5$ mV | HP 6294A | P,A |
| Mixer | Frequency Range: 1 to 26 GHz | RHG DMS 1-26 | P,AT,A |
| Feedthrough Termination | 50 Ohm feedthrough | HP 10100C | P |
| Attenuators | Frequency Range: 0.01 to 26.5 GHz Maximum Input Power: $>+10$ dBm Attenuation: 10 dB Connectors: APC-3.5 Frequency Range: 0.01 to 26.5 GHz Maximum Input Power: $>+10$ dBm Attenuation: 20 dB Connectors: APC-3.5 | HP 8493C Opt. 010 HP 8493C Opt. 020 | P,AT,A P,AT |

Table 1-2. Recommended Test Equipment (3 of 5)

| Instrument | Critical Specifications | Recommended Model | Use ¹ |
|---------------------------------------|--|---|---|
| Step Attenuator | Calibrated at 50 MHz 0 to 70 dB in 10 dB steps | HP 355D | AT |
| Directional Coupler | Frequency Range: 1.7 to 26.5 GHz Coupling: 16 dB Maximum Input Power: 100mW | HP Part No. 0955-0125 | A |
| Adapters | APC-3.5 Female to Female (2 required) BNC Female to Dual Banana SMB Male to SMB Male SMC Female to BNC Female SMA Male to BNC Female APC 3.5 Male to Type N Male APC 3.5 Female to Type N Male | HP Part No. 5061-5311 ² 1251-2277 1250-0069 1250-0832 1250-1200 1250-1743 1250-1744 ² | P, A, T P A P P P P, A, T |
| Adapter Tees | BNC Male-Female-Female SMB Male-Male-Male | HP Part No. 1250-0781 1250-0670 ² | P T |
| Active Probe | Input Impedance: 100 KOhms Output Impedance: 50 Ohms | HP 1121A | T, A |
| Probe Power Supply | For HP 1121A | HP 1122A | T, A |
| High Pass Filter (1 each required) | Frequency Range: 18.0 to 26.5 GHz Connectors: APC-3.5 Female APC-3.5 Male | HP K281C HP K281C Opt. 012 | P P |
| Low Pass Filter | Pass 100 MHz and below Reject 150 MHz and above | HP Part No. 9135-0260 | P, AT |
| Crystal Detector | Positive or Negative Frequency Range: 10 MHz to 26.5 GHz | HP 8473C | P, T |
| Diode (2 required) | Peak Inverse Voltage: 400V Average Forward Current: 750 mA | HP Part No. 1901-0028 | P |
| Capacitors | 1000 pF ($\pm 10\%$), 100 VDC 0.1 μ F ($\pm 10\%$), 200 VDC | HP Part No. 0160-4574 0160-0168 | P A |
| Resistor | 1 MOhm, 1%, 0.5 Watt | HP Part No. 0757-0059 | A |
| PC Board Extenders | 24-pin 30-pin 36-pin 44-pin 48-pin 62-pin 110-pin | HP Part No. 08340-60095 ² 08505-60041 ² 08505-60042 ² 08350-60031 ² 08340-60050 ² 08340-60096 ² 08340-60033 ² | T T T T T T T |

Table 1-2. Recommended Test Equipment (4 of 5)

| Instrument | Critical Specifications | Recommended Model | Use ¹ |
|-----------------|--|--|------------------------|
| IC Test Clip | 16-pin 20-pin | HP Part No. 1400-0734 ² 1400-0979 ² | T T |
| Adjustment Tool | Fits adjustment slot on components | HP Part No. 8830-0024 ² | T |
| Service Cables | BNC (Male) to SMB (Female) (2 required) 61 mm (2 ft), 0.85 in., semi-rigid, SMA Male to SMA Male (2 required) 30 mm (12 in) SMB (Female) to SMB (Female) | HP Part No. 085680-60093 ² 08340-20124 ² 5061-1022 ² | T P,AT,A,T T |
| Nut Driver | 9/16 inch, to replace front panel BNC nuts | HP Part No. 08340-20099 ² | T |
| Wrench | 5/16-inch slotted box/open end | HP Part No. 08555-20097 ² | T |
| Notch Filter | At least 35 dB rejection at 1 MHz Construct as shown below. The filter rejection should be: ≥ 35 dB at 1 MHz < 26 dB at 1.01 MHz | Locally Fabricate | P |

Table 1-2. Recommended Test Equipment (5 of 5)

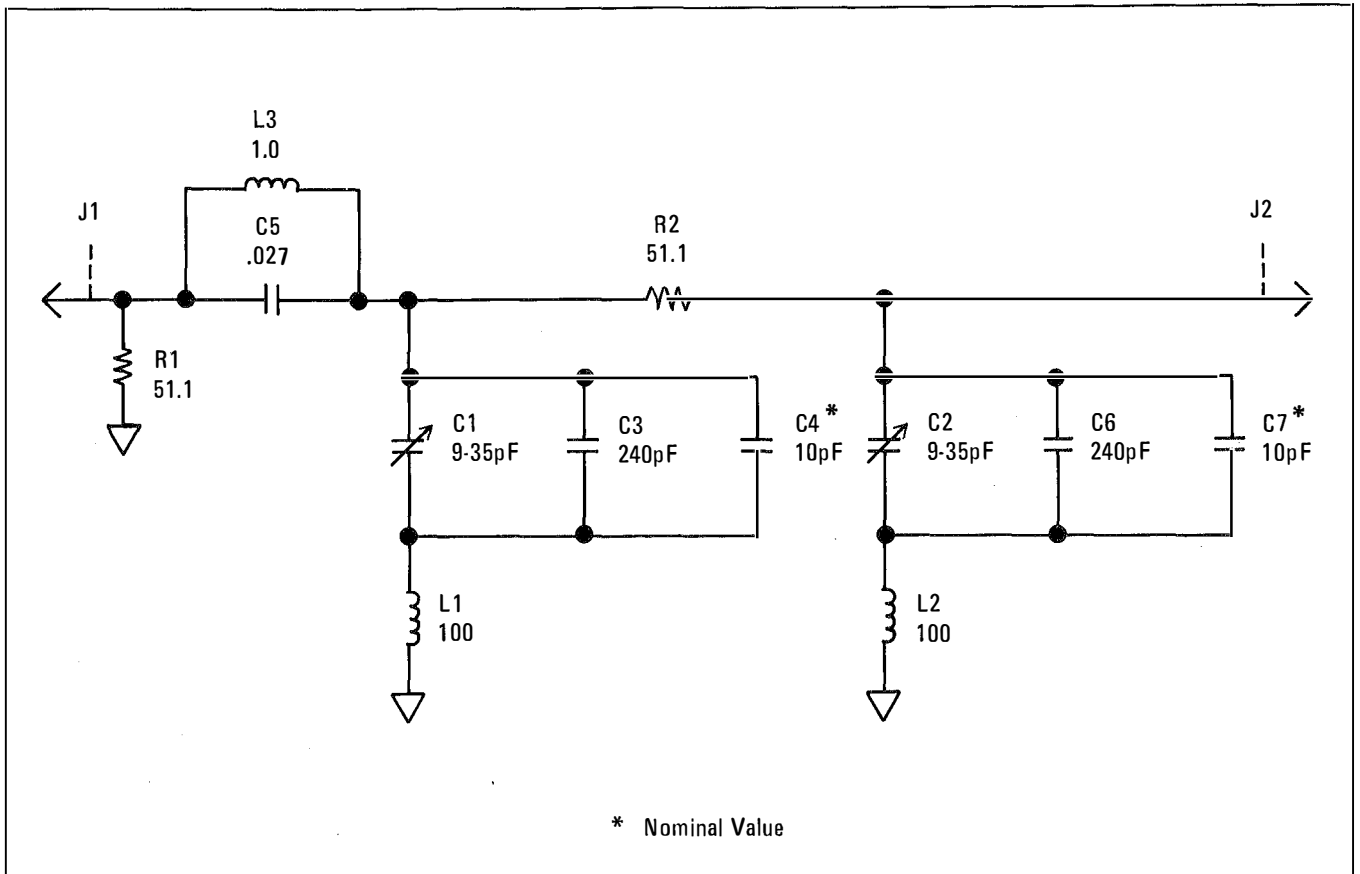

| Reference Designator | Description | HP Part No. | Qty |
|----------------------|-----------------------------|-------------|-----|
| C1,2 | CAPACITOR-VAR CER 9-35PF | 0121-0046 | 2 |
| C3,6 | CAPACITOR-MICA 240PF 300V | 0140-0199 | 2 |
| C4,7 | CAPACITOR-CERAMIC 10PF 100V | 0160-4791 | 2 |
| C5 | CAPACITOR-PE .027μF 200V | 0170-0066 | 1 |
| J1,2 | CONNECTOR RF MALE SMB | 1250-0257 | 2 |
| L1,2 | COIL 100μH 5% | 9140-0210 | 2 |
| L3 | COIL 1.0μH 5% | 9100-3551 | 1 |
| R1,2 | RESISTOR 51.1 1% .125W | 0757-0394 | 2 |

1. P=Performance Tests, HP-IB=HP-IB Operation Verification Test, AT=Automated Tests, A=Adjustments, T=Troubleshooting. Refer to the Recommended Test Equipment text in Section I for further information on the Automated Test Procedure's equipment requirements.
2. These parts are included in Service Kit HP Part Number 08340-60134.
3. For best accuracy in the Pulse Modulation Rise and Fall Time and the Amplitude Modulation Performance Tests, the Local Oscillator drive to the mixer should be $\geq +6$ dBm. The 8340A Option 001, used as the LO will typically produce +6 dBm at any frequency (although it is only guaranteed to produce +4 dBm above 23 GHz. If +6 dBm is not available at a desired test frequency, try a slightly different frequency and be sure to have [PEAK] on.

SECTION II INSTALLATION

2-1. INTRODUCTION

2-2. This section provides installation instructions for the HP 8340A Synthesized Sweeper. This section also includes information about initial inspection, damage claims, preparation for use, packaging, storage and shipment, and Operation Verification.

2-3. INITIAL INSPECTION

2-4. Inspect shipping container for damage. If the shipping container or cushioning material is damaged, it should be kept until the contents of the shipment have been checked for completeness and the instrument has been checked mechanically and electrically. The contents of the shipment should be as shown in Figure 1-1. Procedures for checking electrical performance are given in Section IV, Performance Tests, in this volume. Performance Test limits are also given in Section IV of this volume. If the instrument combination does not pass the electrical Performance Tests, refer to Section V, Adjustments, in Volume 2. If, after the adjustments have been made, the instrument combination still fails to meet specifications, and a circuit malfunction is suspected, refer to troubleshooting procedures in Section VIII, Service, in Volumes 3 and 4. If the instrument does not pass the above electrical tests, if the shipment contents are incomplete, or if there is mechanical damage or defect, notify the nearest Hewlett-Packard office. If the shipping container is damaged, or if the cushioning material shows signs of stress, notify the carrier as well as the Hewlett-Packard office. Keep the shipping materials for carrier's inspection. The HP office will arrange for repair or replacement without waiting for claim settlement.

2-5. PREPARATION FOR USE

2-6. Power Requirements

2-7. The HP 8340A Synthesized Sweeper requires a power source of 100, 120, 220, or 240

Vac ($\pm 10\%$), 47.5 to 66 Hz, single-phase. Power consumption is approximately 500 VA (40 VA in STANDBY).

2-8. Line Voltage and Fuse Selection



To prevent damage to the instrument, make the correct line voltage and fuse selection before connecting line power to the instrument.

2-9. Figure 2-1 illustrates the line voltage selection cam and fuse location in the power line module on the rear panel of the HP 8340A. Select the line voltage and fuse rating as follows:

- a. Measure the ac line voltage available.
- b. Refer to Table 2-1. Remove the line voltage selection cam from the line module. Select the correct position of the cam (shown in Figure 2-1) by matching the measured ac line value to the correct range indicated in the table. Note that the line voltage ranges given are within $\pm 10\%$ of the nominal line voltage. If the available line voltage does not fall within this range, you must use an autotransformer between the power source and the HP 8340A to bring the line voltage within tolerance.
- c. Install the line voltage selector cam in the power line module as shown in Figure 2-1.
- d. Select the proper fuse to install. The fuse ratings are indicated in Table 2-1 as well as next to the power line module on the rear panel of the instrument.

2-10. Power Cable

In accordance with international safety standards, this instrument is equipped with a three-wire power cable. When connected to an

appropriate power line outlet, this cable grounds the instrument cabinet. Table 2-2 shows the styles of plugs available on power cables supplied with Hewlett-Packard instruments. The HP Part Numbers indicated are part numbers for the complete power cable/plug set. The specific type of power cable/plug shipped with the instrument depends upon the country of shipment destination.

Table 2-1. Line Voltage/Fuse Selection

| Measured ac Line Voltage | Line Voltage Selection Cam | Fuse/HP Part Number |
|--------------------------|----------------------------|---------------------|
| 90 to 110 volts | 100 | 5.0A 2110-0010 |
| 108 to 132 volts | 120 | 4.0A 2110-005 |
| 198 to 242 volts | 220 | 3.0A 2110-0003 |
| 216 to 264 volts | 240 | 2.0A 2110-0002 |

2-12. The offset prong of the three-prong connector is the grounding pin. The protective grounding feature may be preserved when operating the HP 8340A from a two-contact outlet by using a three prong to two prong adapter and connecting the green wire of the adapter to ground. An adapter is available (for US connectors only) as HP Part Number 1251-0048.

2-13. HP-IB Address Selection

2-14. The HP 8340A is addressed by an instrument controller on the HP-IB bus by means of a two-digit numerical HP-IB address. This address is set at the factory to 19 but it may be reset by the user to any value between 0 and 31. The HP-IB address is displayed in the ENTRY DISPLAY window upon power up. Pressing [SHIFT] [LOCAL] will also cause the current HP-IB address of the HP 8340A to be displayed in the ENTRY DISPLAY. The HP-IB address may be changed by entering the key sequence: [SHIFT] [LOCAL] (new address value; between 0 and 31) [Hz]. For example, to set the HP-IB Address to 12, press [SHIFT] [LOCAL] [1] [2] [Hz]. The HP-IB address is

CAUTION:

Do not attempt to rotate the voltage selector cam while it is installed in the line module or non-repairable damage will result. The cam must be completely removed from the line module, rotated to the proper position, and reinstalled. Refer to the instructions below.

Replacement of fuse



1. Pry open line module cover door.
2. Pull out fuse carrier.
3. Insert fuse of proper rating.
4. Place carrier back into line module

Selection of Operating Voltage

1. Pry open line module cover door.
2. **REMOVE CAM FROM THE LINE MODULE.**
3. Rotate the cam to the desired voltage. (When the line module cover is closed, the selected voltage will be visible through a small window.)
4. Insert the cam back into the line module.
5. Close the line module cover door.

Figure 2-1. Power Line Module

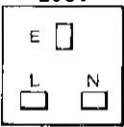
Table 2-2. AC Power Cables Available

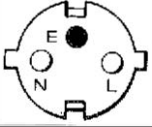
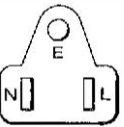
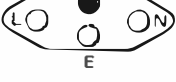
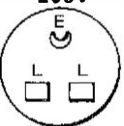
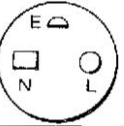
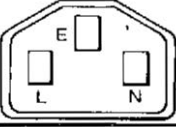
| Plug Type ¹ | Cable HP Part Number ² | CD ³ | Plug Description ² | Cable Length (inches) | Cable Color | For Use in Country |
|--|--|----------------------------|--|----------------------------------|--|--|
| 250V  | 8120-1351 8120-1703 | 0 6 | Straight BS1363A 90° | 90 90 | Mint Gray Mint Gray | United Kingdom, Cyprus, Nigeria, Zimbabwe, Singapore |
| 250V  | 8120-1369 8120-0696 | 0 4 | Straight NZSS198/ASC112 90° | 79 87 | Gray Gray | Australia, New Zealand |
| 250V  | 8120-1689 8120-1692 | 7 2 | Straight CEE7-VII 90° | 79 79 | Mint Gray Mint Gray | East and West Europe, Saudi Arabia, Egypt, Republic of So. Africa, India (unpolarized in many nations) |
| 125V  | 8120-1348 8120-1398 8120-1754 8120-1378 8120-1521 8120-1676 | 5 5 7 1 6 2 | Straight NEMA5-15P 90° Straight NEMA5-15P 90° Straight NEMA5-15P | 80 80 36 80 80 36 | Black Black Black Jade Gray Jade Gray Jade Gray | United States, Canada, Japan (100V or 200V), Mexico, Philippines, Taiwan |
| 250V  | 8120-2104 | 3 | Straight SEV1011.1959 24507, Type 12 | 79 | Gray | Switzerland |
| 250V  | 8120-0698 | 6 | Straight NEMA6-15P | | | United States, Canada |
| 220V  | 8120-1957 8120-2956 | 2 3 | Straight DHCK 107 90° | 79 79 | Gray Gray | Denmark |
| 250V  | 8120-1860 | 6 | Straight CEE22-V1 (System Cabinet Use) | | | |

1. E = Earth Ground; L = Line; N = Neutral
2. Part number shown for plug is industry identifier for plug only. Number shown for cable is HP Part Number for complete cable including plug.
3. The Check Digit (CD) is a coded digit that represents the specific combination of numbers used in the HP Part Number. It should be supplied with the HP Part Number when ordering any of the power assemblies listed above, to expedite speedy delivery.

retained in memory when the instrument is in STANDBY as well as when ac line power is removed from the instrument (as long as the batteries on the A61 Memory assembly have the proper capacity).

NOTE

An instrument address that is input by the above [SHIFT] [LOCAL] sequence is stored in a memory area referred to as "USER" memory. This address will remain in effect as long as the battery backup circuit is operating properly or until the address is changed with another [SHIFT] [LOCAL] sequence. In the event of an instrument memory problem, the value stored in "USER" may be replaced by the value "19" (a default value). If this occurs, an instrument failure may have occurred. Refer to detailed information regarding Calibration Constants in Section VIII, Service in this manual.

2-15. Interface Function Codes

2-16. The Interface Function Codes for the HP 8340A are an alphanumeric coded set that describes its operational capabilities on the HP-IB bus. The codes for the HP 8340A are:

SH1, AH1, T6, TE0, L4, LE0, SR1, RL1, PP0, DC1, DT1, C0, C1, C2, C3, C28, E1.

2-17. Mating Connectors

2-18. All of the externally mounted connectors on the Model 8340A are listed in Table 2-3. Opposite each connector is an industry identification, the HP part number of a mating connector, and the part number of an alternate source for the mating connector. For HP part numbers of the externally mounted connectors themselves, refer to Section VI, Replaceable Parts, of this manual.

2-19. HP-IB, 8410, and 8755 INTERFACE Connectors

2-20. Figure 2-2 shows the signal/pin configuration of the rear panel HP-IB connector. The

same information is shown for the 8410 INTERFACE connector in Figure 2-3 and for the 8755C INTERFACE connector in Figure 2-4.

2-21. Internal Oscillator Selection and Warmup Time

2-22. The rear panel FREQUENCY STANDARD toggle switch (shown in Figure 2-5) must be in the INT position and the rear panel BNC jumper cable must be connected between the INT and EXT connectors for the instrument to operate properly when using the internal time base standard. By disconnecting the jumper from the INT connector, setting the switch to EXT, and injecting a 10 MHz signal (approximately +3 dBm, 50 Ohm nominal input impedance) from an external source, the 8340A can be phase locked to other instruments in a specific test setup. Sharing a common frequency reference will eliminate frequency errors between the instruments due to varying internal oscillator frequencies.

2-23. The instrument must be connected to the ac power line in order to keep the Model 8340A internal time base frequency standard oven operating at temperature. The instrument requires approximately 30 minutes to warm up from a cold start before the front panel OVEN annunciator goes out. Internal temperature equilibrium is reached after approximately 2 hours with a stable outside temperature. Refer to the instrument specifications in Section I, General Information, in this volume for additional information on warm up times.

2-24. Operating Environment

2-25. Temperature. The instrument may be operated in temperatures from 0°C to +55°C.

2-26. Humidity. The instrument may be operated in environments with humidity from 5% to 80% relative at +25°C to +40°C. However, the instrument should also be protected from temperature extremes that could cause condensation within the instrument.

2-27. Altitude. The instrument may be operated at altitudes up to 4572 meters (approximately 15,000 feet).

Table 2-3. Model 8340A Mating Connectors

| 8340A Connector | | Mating Connector | |
|--|--------------------------|---|-----------------------------------|
| Connector Name | Industry Identification | HP Part Number | Alternate Source |
| J1 SWEEP OUTPUT J2 PULSE J3 AM J4 EXT (Leveling) INPUT | BNC (female) | 1251-0256 | Speciality Connector 25-P118-1 |
| J5 RF OUTPUT** | APC 3.5 (male) | Any industry standard APC 3.5 (female). | |
| J6 1V/GHz J7 SWEEP OUTPUT J8 10 MHz REF OUTPUT J9 INT J10 EXT J11 EXT TRIGGER INPUT J12 MUTE OUTPUT J13 PEN LIFT OUTPUT J14 NEG BLANK J15 Z-AXIS BLANK/MKRS J16 STOP SWP IN/OUT | BNC (female) | 1251-0256 | Specialty Connector 25-P118-1 |
| J17 8755C INTERFACE* | Audio 3-Pin Connector | N/A | Switchcraft TA-3F |
| J18 8410 INTERFACE | 25-Pin D Series | 1251-0063 | ITT Cannon DBM-25P |
| J19 AUX OUTPUT | Type N (female) (50 ohm) | Any industry standard 50 ohm Type N (male). | |
| J20 RF OUTPUT** | APC 3.5 (male) | Any industry standard APC 3.5 (female). | |
| J21 HP-IB*** | 24-Pin Micro Ribbon | 1251-0293 | Amphenol 57-30240 |
| <p>* A 1219mm (48 inch) cable assembly with a Switchcraft TA-3F Audio 3-pin connector on each end is supplied with the Model 8755C Swept Amplitude Analyzer as the Alternate Sweep Interface Cable. The complete cable may be ordered separately as HP Part Number 8120-3174. The ALT SWP INTERFACE connector J17 signal/pin configuration is shown in Figure 2-4.</p> <p>** Options 004 and 005 only, delete J5, add J20.</p> <p>*** HP-IB interface connector J21 signal/pin configuration is shown in Figure 2-2.</p> | | | |

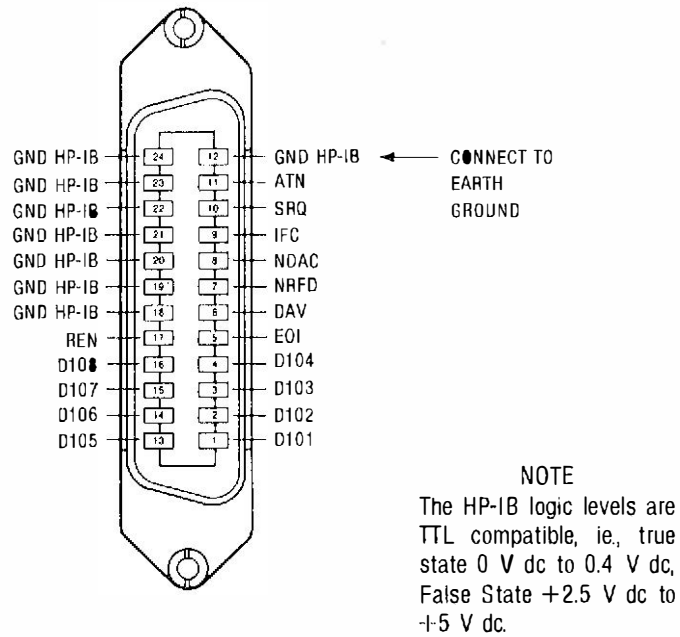

| Mnemonics Table | |
|------------------------|---------------------------------------|
| Mnemonic | Description |
| L ATN | LOW = Attention control line |
| L DAV | LOW = Data Valid control line |
| L DIO1 thru 8 | LOW = Data Input/Output control lines |
| L EO1 | LOW = End Or Identify control line |
| L IFC | LOW = Interface Clear control line |
| L NDAC | LOW = Data Not Accepted control line |
| L NRFD | LOW = Not Ready For Data control line |
| L REN | LOW = Remote Enable control line |
| L SRQ | LOW = Service Request control line |

Figure 2-2. HP-IB Connector Signal/Pin Configuration

8410C INTERFACE CONNECTOR J17
(As seen from rear panel)

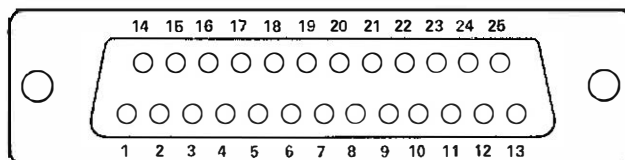

| Pin | Mnemonic | Description ¹ | In/Out ² |
|-----|------------|--------------------------------------|---------------------------|
| 1 | | No Connection | |
| 2 | Z-AXIS | LOW=Marker Pulse ($\pm 5V$) | Output |
| 3 | | No Connection | |
| 4 | LALTSEL | Alternate Sweep (LSTTL) | Output |
| 5 | LSSP | LOW=Stop Forward Sweep Request | Input/Output ³ |
| 6 | +5.2V | +5 Volts (100 mA Max.) | Output |
| 7 | | No Connection | |
| 8 | MUTE | LOW=RF Blank Request (LSTTL) | Input |
| 9 | EXT TRIG | HIGH=External Trigger Sweep (LSTTL) | Input |
| 10 | PEN LIFT | HIGH=Pen Lift | Output ³ |
| 11 | | No Connection | |
| 12 | | No Connection | |
| 13 | | No Connection | |
| 14 | NEG BLANK | LOW=Blanking Pulse ($-5V$) | Output |
| 15 | | No Connection | |
| 16 | LRETRACE | LOW=Retrace Strobe (LSTTL) | Output |
| 17 | LALTEN | LOW=Alternate Sweep Enable (LSTTL) | Output |
| 18 | | No Connection | |
| 18 | GND | Digital Ground/Pen Lift Return | |
| 20 | | No Connection | |
| 21 | | No Connection | |
| 22 | LSTEPUP | LOW=Step Advance (SW. to GND (0.4V)) | Input |
| 23 | | No Connection | |
| 24 | 8410B TRIG | HIGH=Synchronizer Trigger (LSTTL) | Output |
| 25 | | No Connection | |

1. LSTTL Logic Levels. INPUTS: Low ≤ 0.8 Vdc, High ≥ 2.0 Vdc.
OUTPUTS: Low ≤ 0.4 Vdc, High ≥ 2.4 Vdc.

2. Control of input lines can be accomplished by contact closure to ground for a logic low level and open circuit for a logic high level.

3. Open Collector Output

Figure 2-3. 8410 INTERFACE Connector Signal/Pin Configuration

| ALTERNATE SWEEP INTERFACE CONNECTOR J17 | | | | | | |
|---|----------|---|------------|-----------------|------------|----------|
| 8755C ALT SWP. INTERFACE  (viewed from rear of instrument) | | | | | | |
| Pin | Mnemonic | Description | Level | Wire Color Code | A62J31 Pin | Source |
| 1 | LALTEN | LOW to Externally Enable ALT SWP Mode in HP 8755C | TTL OUTPUT | 9 - 1 - 5 | 23 | A57P1-60 |
| 2 | LALTSEL | Channel Select (HIGH =Channel 1, LOW =Channel 2) | TTL OUTPUT | 9 - 1 - 6 | 24 | A57P1-59 |
| 3 | LRETRACE | LOW During Retrace | TTL OUTPUT | 9 - 1 - 7 | 25 | A57P1-58 |

Figure 2-4. 8755C INTERFACE Connector Signal/Pin Configuration

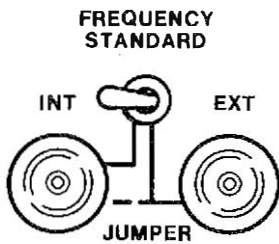

Figure 2-5. Rear Panel FREQUENCY STANDARD Switch

2-28. Cooling. The Model 8340A obtains all of its cooling airflow by forced ventilation from the fan mounted on the rear panel. The cooling airflow path is as follows: into the fan from the rear of the instrument, past the internal circuitry, and out the vents in the right side panel and the rear panel heat sink assembly.

CAUTION

Ensure that all airflow passages at the rear and sides of the Model 8340A are clear before installing

the instrument in its operating environment. This is especially important when using the Model 8340A in a rack mounted instrument configuration.

2-29. Front Handles Kit

2-30. All standard instruments are supplied with a front handles kit. This kit must be installed by the user as illustrated in Figure 2-6.

2-31. Chassis Slide Kit (Option 806)

2-32. Option 806 instruments are supplied with a Chassis Slide Kit that must be installed by the user. This kit and its mounting instructions are illustrated in Figure 2-7.

2-33. Rack Flange Kit (Option 908)

2-34. Option 908 instruments are supplied with a Rack Flange Kit. This kit includes only rack flanges; it does not include handles. Mounting instructions are illustrated in Figure 2-8.

2-35. Rack Mounting with Handles (Option 913)

2-36. Option 913 instruments are supplied with rack mount flanges and front handles. This kit may be installed by the user as illustrated in Figure 2-9.

2-37. STORAGE AND SHIPMENT

2-38. Environment

2-39. The instrument may be stored or shipped in environments within the following limits:

- Temperature -40°C to +75°C
- Humidity 5% to 95%
relative at 0° to +40°C
- Altitude Up to 15240 meters
(approximately 50,000 feet)

2-40. The instrument should also be protected from temperature extremes that could cause condensation in the instrument.

2-41. Packaging

2-42. Original Packaging. Containers and materials identical to those used in factory packaging are available through Hewlett-Packard offices. Original packaging items are shown in Figure 2-10. The instrument front handles must be replaced by the shipping bars when the original packaging materials are used. If the instrument is being returned to Hewlett-Packard for servicing, attach a tag indicating the type of service required, return address, model number, and full serial number located on rear panel serial plate). Mark the container FRAGILE to assure careful handling. In any correspondence, refer to the instrument by model number and full serial number.

2-43. Other Packaging. The following general instructions should be used for repackaging with commercially available packaging materials:

- a. Wrap the instrument in heavy paper or plastic. If shipping to a Hewlett-Packard Office or Service Center, attach a tag indicating the type of service required, return address, model number, and full serial number.
- b. Use a strong shipping container.
- c. Use enough shock-absorbing material around all sides of the instrument to provide a firm cushion and to prevent movement inside the container. Protect the control panel with cardboard.
- d. Seal the shipping container securely.
- e. Mark the shipping container FRAGILE to assure careful handling.
- f. In any correspondence, refer to the instrument by model number and full serial number.

2-44. Blue Service Tags

2-45. Before sending the instrument back to the HP Service organization, attach a blue service tag, located at the rear of this section, to the instrument. Fill out the tag thoroughly to aid the service technician in isolating the specific fault(s) as quickly as possible.

2-46. INCOMING INSPECTION PROCEDURE

2-47. Several forms of an incoming inspection procedure are available in this manual. Section III, Operation, in this volume includes a section on "Getting Acquainted with the 8340A" that may be used to quickly verify operational functions when the instrument is first received. Section IV, Performance Tests, and the HP-IB Operation Verification procedure (also located in Section IV) should be used to verify that the instrument matches its published specifications and performance characteristics.

FRONT HANDLE KIT

HP PART NUMBER 5061-0090

CONTENTS

| QTY. | | PART NO. |
|------|--------------------|-----------|
| 2 | FRONT HANDLE ASS'Y | 5060-9900 |
| 2 | FRONT HANDLE TRIM | 5020-8897 |
| 8 | #8-32 x 3/8 SCREW | 0515-0896 |

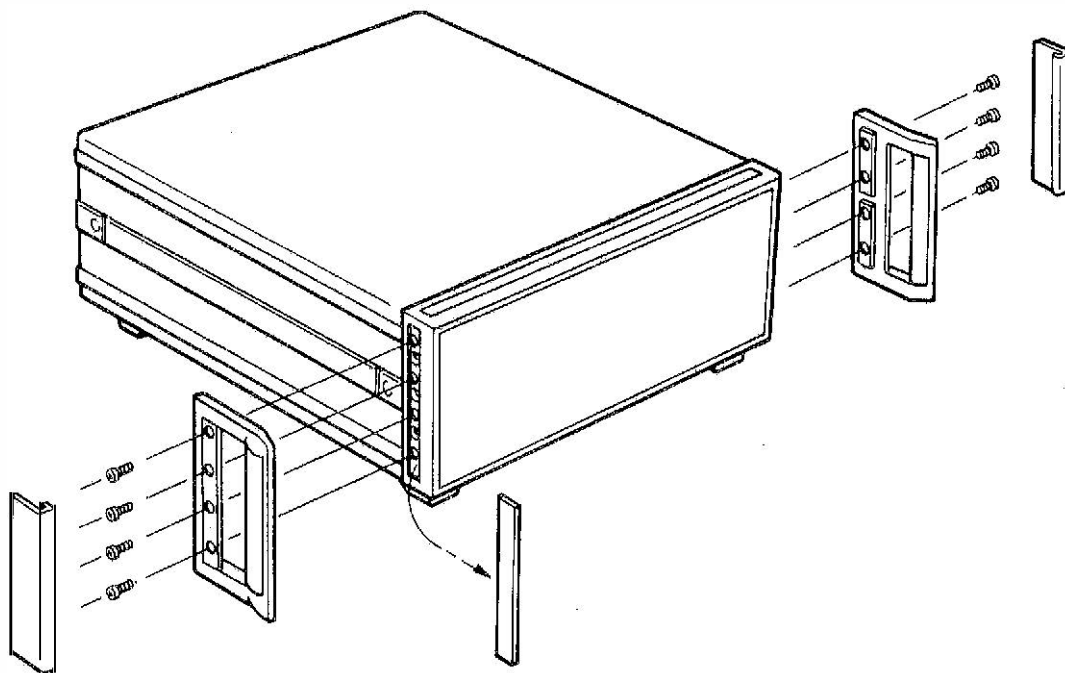

INSTRUCTIONS

1. REMOVE SIDE TRIM STRIPS.
2. ATTACH FRONT HANDLE ASS'Y WITH 4 SCREWS PER SIDE.
3. PRESS FRONT HANDLE TRIM IN PLACE.

Figure 2-6. Mounting the Front Handles Kit

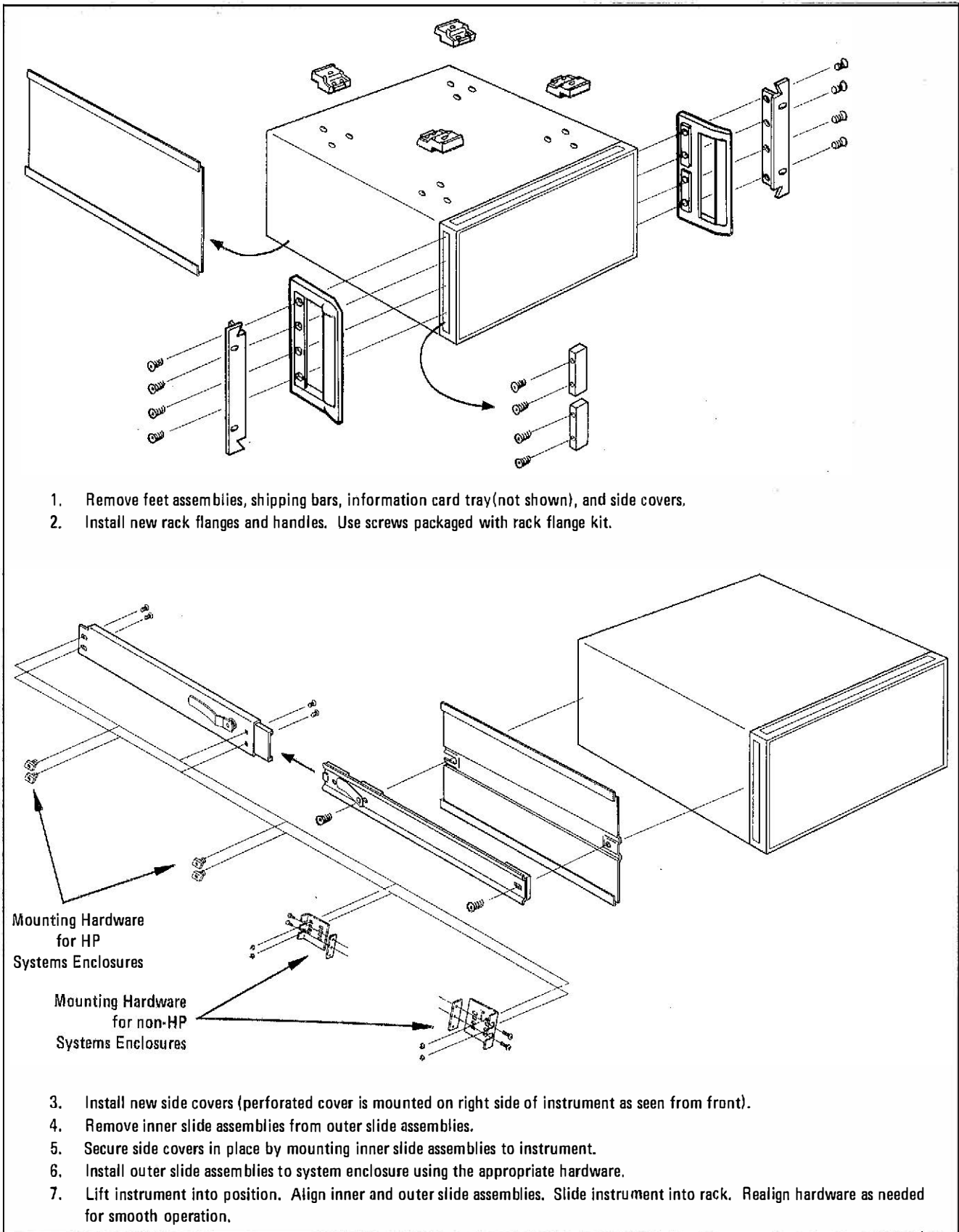

Figure 2-7. Chassis Slide Kit Mounting Instructions (Option 806) (1 of 2)

| HP Part Number | Qty | CD | Description |
|--|-----|----|---|
| 5061-9772 | 1 | 6 | Rack Mount Kit, Metric (Includes the following parts) |
| 5020-8875 | 2 | 2 | RACK MOUNT FLANGE |
| 2510-0194 | 8 | 8 | SCREW-MACH 8-32 .625-IN-LG PAN-HD-POZI |
| 5061-0090 | 1 | 3 | Handles Kit (Refer to Figure 2-6) |
| 5060-9884 | 1 | 9 | SIDE COVER – LEFT |
| 5060-9942 | 1 | 0 | SIDE COVER – RIGHT (PERFORATED) |
| 1494-0059 | 1 | 7 | Slide Kit, Metric (HP Systems Enclosures) (Includes the following parts) |
| | | | MODIFIED SLIDE ASSEMBLY, Metric (Includes Inner and Outer Slides) |
| 2510-0105 | 4 | 1 | SCREW-MACH 8-32 .438-IN-LG PAN-HD-POZI |
| 2510-0104 | 4 | 0 | SCREW-MACH 8-32 .438-IN-LG 100 DEG |
| 0590-0818 | 8 | 9 | NUT-CHANNEL 8-32-THD .406-WD STL |
| 2680-0143 | 4 | 6 | SCREW-MACH 10-32 .562-IN-LG PAN-HD-POZI |
| 1494-0061 | 1 | 1 | Slide Adapter Kit, Metric (NON-HP systems Enclosures) (Includes the following parts) |
| — | 4 | — | ADAPTER BRACKETS, Metric |
| 2680-0103 | 8 | 8 | BAR NUTS 10-32 |
| 2580-0003 | 8 | 5 | SCREW-MACH 10-32 .5-IN-LG PAN-HD-POZI |
| 2510-0100 | 4 | 6 | NUT-HEX-W/LKWR 8-32-THD .125-IN-THK |
| 2510-0101 | 4 | 7 | SCREW-MACH 8-32 .312-IN-LG 100 DEG |
| | | | SCREW-MACH 8-32 .312-IN-LG PAN-HD-POZI |
| All above parts may be ordered as the Chassis Slide Kit, HP Part Number 08340-60136. | | | |

Figure 2-7. Chassis Slide Kit Mounting Instructions (Option 806) (2 of 2)

RACK MOUNT KIT WITHOUT FRONT HANDLES

HP PART NUMBER 5061-0078 (OPTION 908)

CONTENTS

| QTY. | | PART NO. |
|-------------|-----------------------------|-----------|
| 2 | RACK MOUNT FLANGE | 5020-8863 |
| 8 | #8-32 x 3/8 SCREW | 2510-0193 |

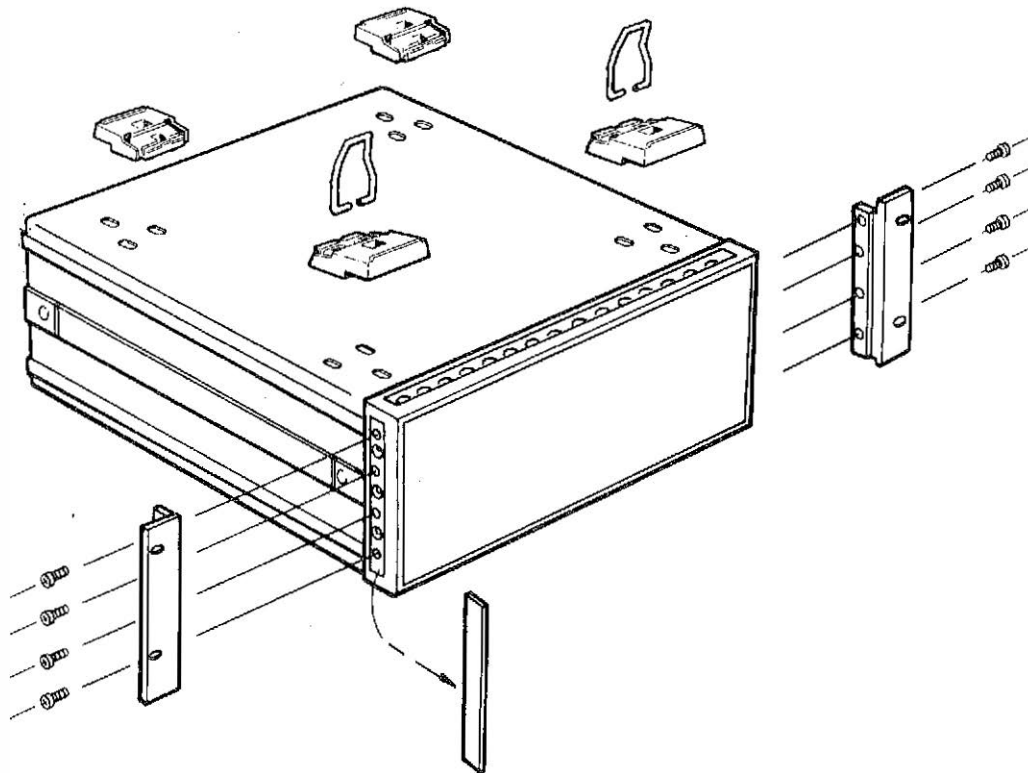

INSTRUCTIONS

1. REMOVE SIDE TRIM STRIPS.
2. ATTACH RACK MOUNT FLANGE WITH 4 SCREWS PER SIDE.
3. REMOVE FEET AND TILT STANDS BEFORE RACK MOUNTING.

Figure 2-8. Rack Flange Kit Mounting Instructions (Option 908)

RACK MOUNT KIT FOR CABINETS WITH PREVIOUSLY ATTACHED FRONT HANDLES

HP PART NUMBER 5061-2072 (OPTION 913)

CONTENTS

| QTY. | | PART NO. |
|------|-------------------------------|-----------|
| 2 | RACK MOUNT FLANGE | 5020-8875 |
| 8 | #8-32 x 5/8 SCREW | 2510-0194 |

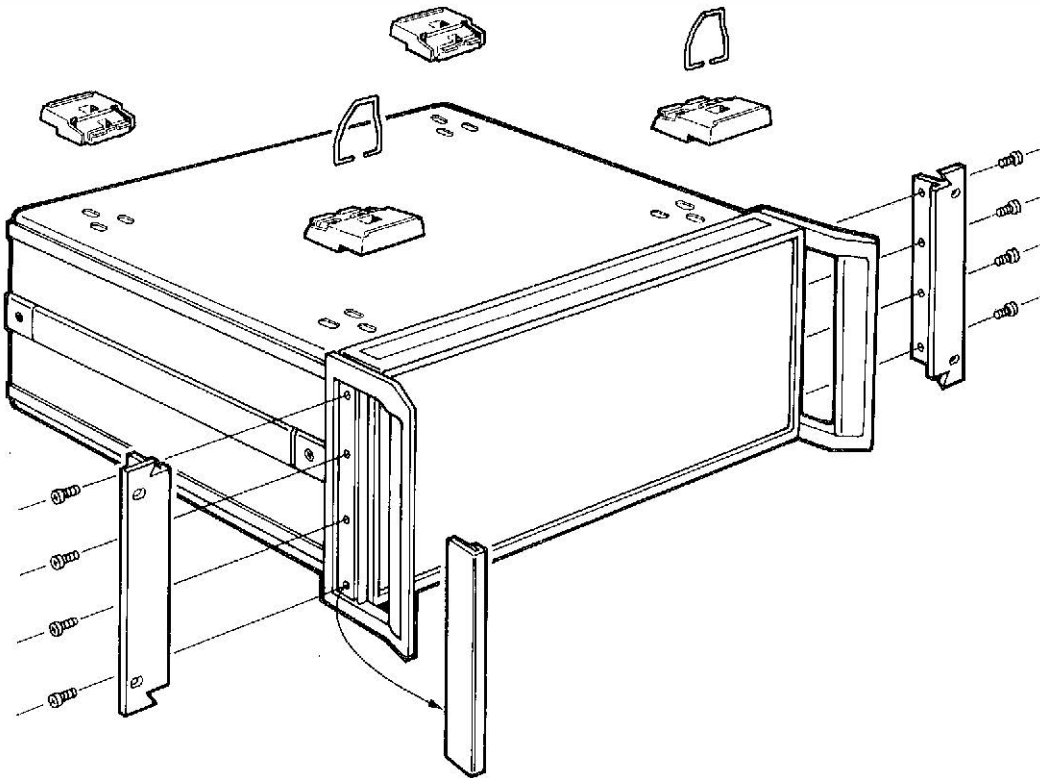

INSTRUCTIONS

1. REMOVE SIDE TRIM STRIPS.
2. REMOVE 4 SCREWS PER SIDE.
3. ATTACH RACK MOUNT FLANGE AND FRONT HANDLE ASS'Y WITH 4 NEW LONGER SCREWS PER SIDE.
4. REMOVE FEET AND TILT STANDS BEFORE RACK MOUNTING.

Figure 2-9. Rack Mounting Kit with Handles (Option 913)

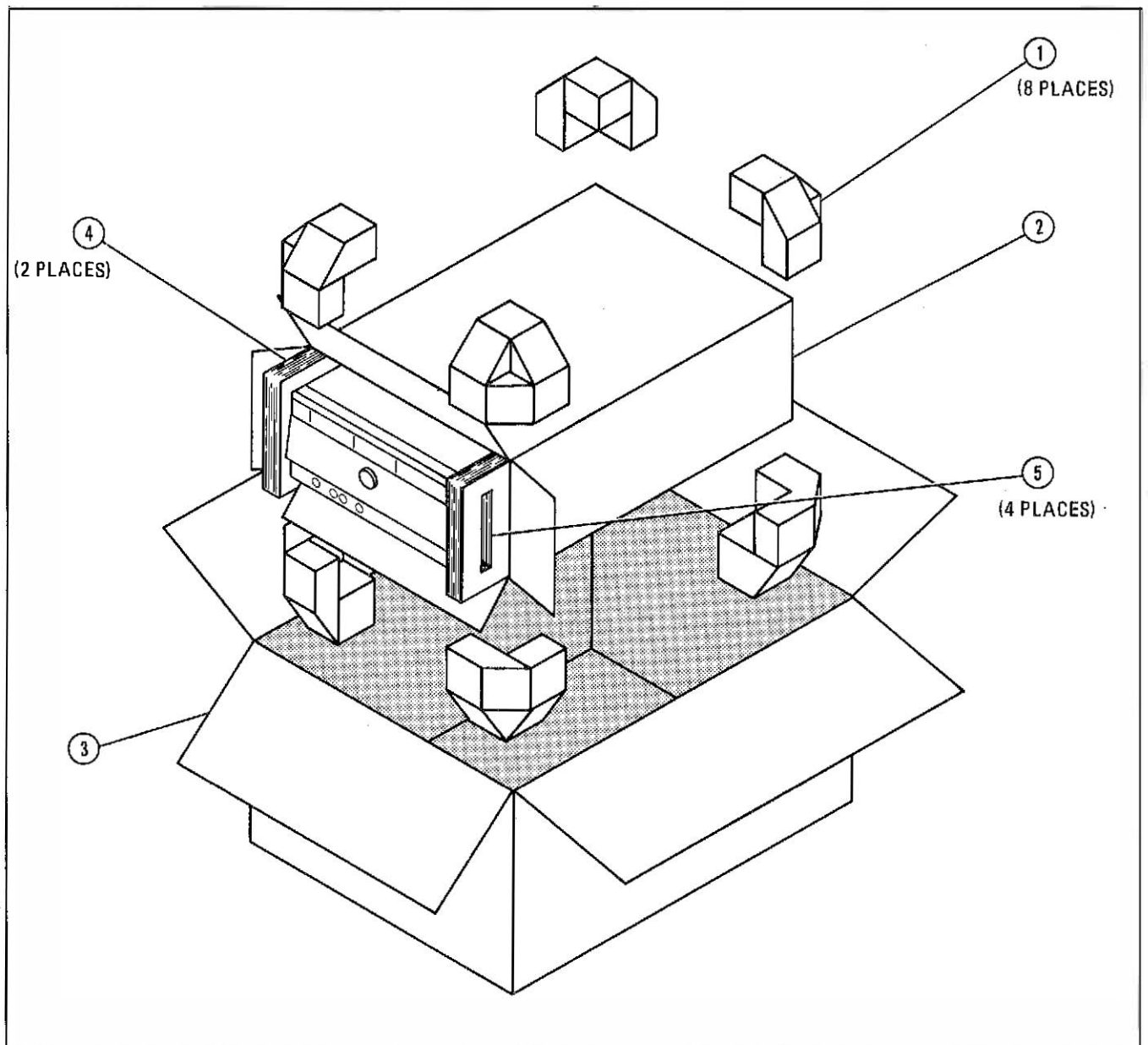

| Item | Qty | HP Part No. | C D | Description |
|------|-----|-------------|--------|--|
| 1 | 8 | 9220-2733 | 7 | FOAM PADS – TOP CORNERS; BOTTOM CORNERS |
| 2 | 1 | 9211-4369 | 2 | CARTON – INNER |
| 3 | 1 | 9211-4370 | 3 | CARTON – OUTER |
| 3 | 1 | 9220-4060 | 7 | SIDE PADS – CORRUGATED CARDBOARD |
| — | 1 | 9222-0069 | 2 | POLY BAG – TO COVER INSTRUMENT (NOT SHOWN) |
| 5 | 4 | 4040-1738 | 3 | SHIPPING BARS |
| — | 8 | 2510-0101 | 7 | SCREW – #8-32x.312 PAN HD (TO MOUNT SHIPPING BARS) |

Figure 2-10. Packaging for Shipment using Factory Packaging Materials

SECTION III OPERATION

INTRODUCTION

The Operation section of this manual consists of the following subsections:

GETTING ACQUAINTED GUIDE describes the basic features and essential operating procedures for local (front panel) and remote (HP-IB) operation of the HP 8340A. Personnel using the HP 8340A for the first time should begin with this Guide.

OPERATION: FRONT/REAR PANEL DESCRIPTIONS, HP-IB PROGRAMMING INFORMATION, and POWER CONTROL/MODULATION FEATURES explains the functions of all front and rear panel keys, switches, connectors, indicators and displays, all HP-IB codes and programming procedures, and all the special features associated with power control and modulation. The front/rear panel information is grouped according to the physical layout of the HP 8340A: Figure 3-1 provides a visual index to the front panel functions, Figure 3-2 is an index to the rear panel functions, and Table 3-1 provides a cross reference between functions/modes and the front panel keys. The HP-IB programming information begins with Table 3-2, which lists all code mnemonics, and the codes and procedures are explained in the subsequent text. The power control and modulation information describes the special procedures that can be used to enhance the performance of these functions.

PROGRAMMING NOTES contain supplemental HP-IB programming information. Two Programming Notes are included:

Quick Reference Guide for the HP 8340A Synthesized Sweeper succinctly lists the input programming codes, and was written for the experienced operator.

Introductory Operating Guide for use with the HP 9826A or HP 9836A BASIC-language computers provides a detailed explanation of HP-IB programming.

OPERATING GUIDES contain specialized application information. This section contains four Operating Guides (in addition to the Getting Acquainted Guide):

Use with X-Y Recorders explains interfacing of the HP 8340A to HP X-Y recorders.

External Leveling of the HP 8340A, describes using crystal detectors or power meters.

Use with the HP 8410B/C Network Analyzer shows interconnections between the HP 8340A, the Network Analyzer, polar and rectangular displays, and transmission/reflection test sets.

Use with the HP 8755 Frequency Response Test Set describes interfacing procedures for the HP 8340A and this scalar network analyzer system.

Contact the nearest HP Sales and Service Office for copies of other Programming Notes and Operating Guides as they become available.

SAFETY

Before applying power, refer to SAFETY CONSIDERATIONS in Section I of this manual. The information, cautions, and warnings in this manual must be followed to ensure safe operating conditions for the instrument and the human operator.

WARNING

Before the instrument's line power cord is plugged in, all protective earth terminals ("ground" connections), extension cords, auto-transformers and other devices that are connected to the HP 8340A should be connected to a protective earth-grounded socket. Any interruption of the protective earth grounding will cause a potential shock hazard that could result in personal injury.

Only fuses with the required current rating and specified type should be used. Do not use repaired fuses or short circuit the fuse holder; to do so could cause a shock or fire hazard.

CAUTION

Before the instrument's line power cord is plugged in, the line power module must be set to the voltage of the power source or damage to the instrument may result.

ADDITIONAL OPERATING INFORMATION

Located underneath the HP 8340A Synthesized Sweeper are pullout information cards that summarize the operating procedures and programming codes for the instrument.

If further information is necessary, contact the nearest Hewlett-Packard Sales and Service Office. The world-wide locations of HP offices are listed inside of the back cover of this manual.

Getting Acquainted with the HP 8340A Synthesized Sweeper

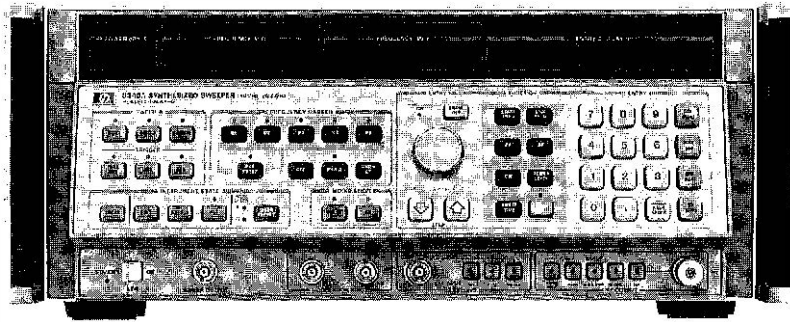

INTRODUCTION

Anyone preparing to use the HP 8340A for the first time should begin by reading this "Getting Acquainted" guide. This guide introduces the basic procedures needed for local (front panel), and remote (computerized) operation of the instrument. An HP 8340A, a computer, and an HP-IB interface cable are all that is required to use this Getting Acquainted guide.

This guide doesn't have any detailed explanations — that is saved for Section III of the HP 8340A Operating and Service Manual. Instead, this guide

is designed as a hands-on introduction to the HP 8340A: press the buttons, program the computer, and watch the displays.

Most of the common operations of the HP 8340A are covered in this guide. The additional, in-depth explanations contained in Section III and the various Operating Guides will be easier to understand after you have completed this introductory material.

The first step in getting started is to check the line power module, as described in the following section.

INSERT IN FRONT OF THE "GETTING ACQUAINTED WITH THE HP 8340A SYNTHESIZED SWEEPER"
OPERATING GUIDE, P/N 08340-90040, IN SECTION III, OPERATION

**SUPPLEMENTAL CHANGES TO "GETTING ACQUAINTED WITH THE HP 8340A SYNTHESIZED
SWEEPER"**

"Getting ACQUAINTED with the HP 8340A Synthesized Sweeper" is a bound section of the manual. This allows the operator to remove the guide for easy reference, However, this feature makes replacement page updates infeasible. This page should be kept with the "Getting ACQUAINTED" guide for reference.

Page 2, Paragraph 1:

Change the paragraph to read:

"If the HP 8340A has just been unpacked, the line power module located on the rear panel of the instrument must be checked for proper fuse rating and the correct positioning of the voltage selector **cam**, as shown in the accompanying illustration. The current line voltage selection is visible through a small window in the line module cover door. **Do not attempt to rotate the line voltage selection cam while it is installed in the line module or non-repairable damage will result. The cam must be completely removed from the line module, rotated to the proper position, and reinstalled. Refer to the instructions in the following figure.**

Page 3, Line Module Illustration:

Replace the existing illustration with the one on the reverse side of this page:

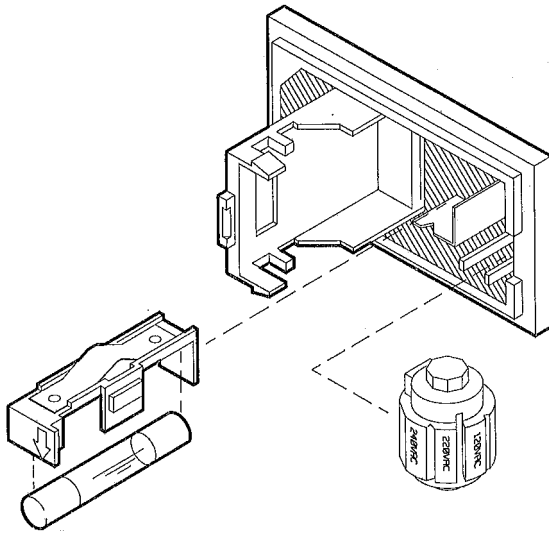
**CAUTION:**

Do not attempt to rotate the voltage selector cam while it is installed in the line module or non-repairable damage will result. The cam must be completely removed from the line module, rotated to the proper position, and reinstalled. Refer to the instructions below.

Replacement of fuse

1. Pry open line module cover door.
2. Pull out fuse carrier.
3. Insert fuse of proper rating.
4. Place carrier back into line module

Selection of Operating Voltage

1. Pry open line module cover door.
2. **REMOVE CAM FROM THE LINE MODULE.**
3. Rotate the cam to the desired voltage. (When the line module cover is closed, the selected voltage will be visible through a small window.)
4. Insert the cam back into the line module.
5. Close the line module cover door.

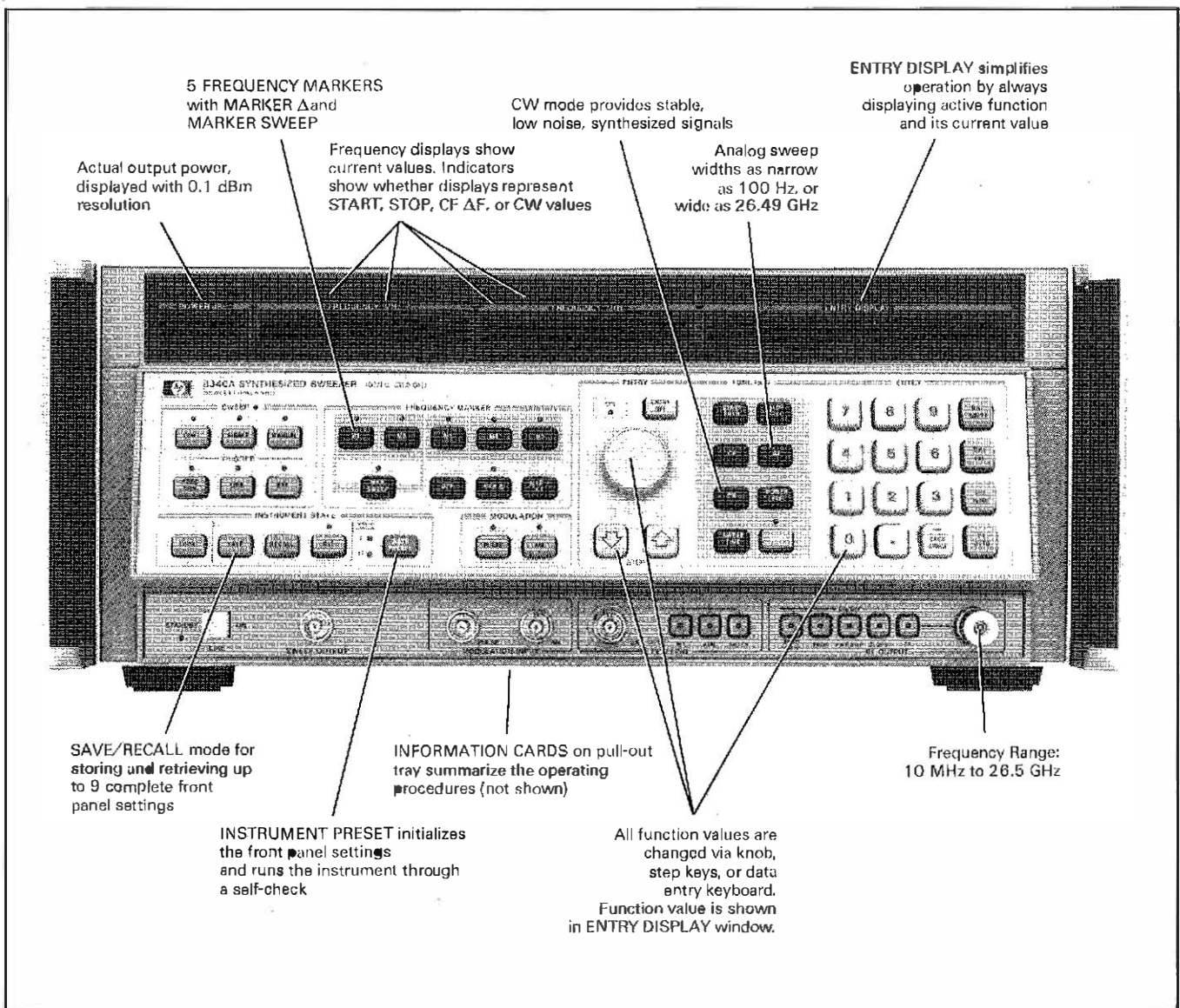

POWER-ON PROCEDURE

If the HP 8340A has just been unpacked, the line-power module located on the rear panel of the instrument must be checked for the proper fuse rating and the correct positioning of the voltage-selector PC board, as shown in the accompanying illustration.

After checking the line-power module, attach the ac power cord and apply power to the instrument. Flip the front-panel switch from STANDBY to ON. Notice that the red OVEN and UNLK (unlocked) annunciators are being displayed in the upper right hand corner of the ENTRY DISPLAY.

One or both of these annunciators will remain on until the crystal oven reaches operating temperature, which will require 5 – 30 minutes from a cold start. When the switch is in STANDBY, the crystal oven remains at operating temperature; therefore, do not unplug the HP 8340A after it has been installed in its work area.

Although the HP 8340A will not fully meet specifications while the OVEN or UNLK annunciators are on, some preliminary checks can be done. These preliminary checks are described in the following Local Operation section.

RECEPTACLE FOR PRIMARY POWER CORD

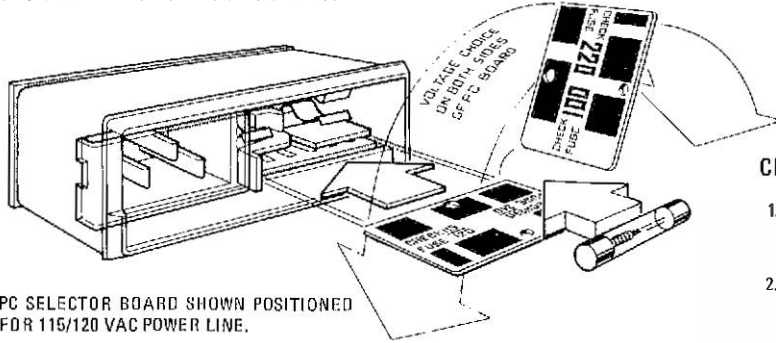

PC SELECTOR BOARD SHOWN POSITIONED FOR 115/120 VAC POWER LINE.

OPERATING VOLTAGE APPEARS IN MODULE WINDOW.

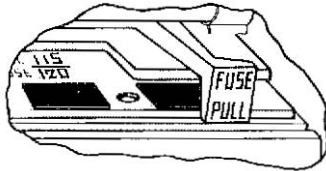

CHECKING THE LINE POWER MODULE

1. SLIDE OPEN POWER MODULE COVER DOOR AND PULL FUSE-PULL LEVER TO LEFT TO REMOVE FUSE.
2. PULL OUT VOLTAGE-SELECTOR PC BOARD. POSITION PC BOARD SO THAT VOLTAGE NEAREST ACTUAL LINE VOLTAGE LEVEL WILL APPEAR IN MODULE WINDOW. PUSH BOARD BACK INTO ITS SLOT.
3. PUSH FUSE-PULL LEVER INTO ITS NORMAL RIGHT-HAND POSITION.
4. CHECK FUSE TO MAKE SURE IT IS OF CORRECT RATING AND TYPE FOR INPUT AC LINE VOLTAGE. FUSE RATINGS FOR DIFFERENT LINE VOLTAGES ARE INDICATED BELOW POWER MODULE.
5. INSERT CORRECT FUSE IN FUSEHOLDER.

LOCAL OPERATION OF THE HP 8340A SYNTHESIZED SWEEPER

Local operation is also called front-panel operation, because the desired HP 8340A functions are initiated by pressing front-panel keys. The first keys to press are those that cause an internal check of the instrument, as described below.

PRELIMINARY CHECKS

Press and hold the **FUNCTION CHECK** key. Notice the red, green, and amber (yellow) LEDs and annunciators: Amber indicates which keys or functions are presently active; the single green LED indicates when the HP 8340A is sweeping (on when sweeping, off during retrace and band-crossings); and red indicates trouble. If any red LED or annunciator turns on (such as OVEN or UNLK seen at cold power-on), refer to the HP 8340A Operating and Service Manual for further instructions.

Release the **FUNCTION CHECK** key, and observe the standard starting conditions: sweeping from 10 MHz to 26.5 GHz, at 0.0 dBm. Press **STOP** at any time to achieve this standard condition, including those times you may need a "panic" button to unscramble all of those keystrokes that you experimentally entered.

The displays are blank during the **FUNCTION CHECK** check. To check the displays, press **STOP**, then the **DISPLAY** key, which will cause every segment of every display element to light followed by a marching display of the entire character set.

To return to standard starting conditions, press either **STOP**, or **FUNCTION CHECK** then **STOP** which will turn off this or any other diagnostic display. A

listing of the other diagnostic functions is contained in the HP 8340A Information Cards.

INFORMATION CARDS

Located below the front panel are information cards that contain a summary of the local and remote commands of the HP 8340A. Slide the cards from their tray, and observe the format of the information: The key-shaped symbols indicate the front-panel keys that are pressed in local operation, the letters and numbers next to the key-shaped symbols are the programming commands used in remote operation, and an explanation of the function follows the symbols and commands.

Under SHIFT KEY FUNCTIONS on the lower information card, find **FUNCTION CHECK** which is the keystroke sequence you just used to activate the display self test. Notice that there are several other built-in diagnostic functions. For example, press **STOP**, then **FUNCTION CHECK** which will display the condition of the internal oscillators (a flashing display indicates an unlocked oscillator; this diagnostic is usually called when the UNLK annunciator is lighted).

Feel free to try any of the functions described on the information cards. The HP 8340A will not be damaged if any keys are pressed in an incorrect sequence. Press **STOP** at any time to return to standard starting conditions.

CW OPERATION

CW operation is one of the major applications of the HP 8340A, and is easy to implement using front-panel keys. In the CW mode, the HP 8340A outputs a single, low-noise, synthesized frequency.

SHIFT, FREERUN
Starts display self test.
SHIFT, M5
Cancels diagnostic functions.

KNOB, STEP keys control active function. **ENTRY DISPLAY** shows active function.

STEP KEY sensitivity:
1. Press **SHIFT,CF**.
2. Enter value.
3. Select frequency unit.
4. Press **CW** to return to CW mode.

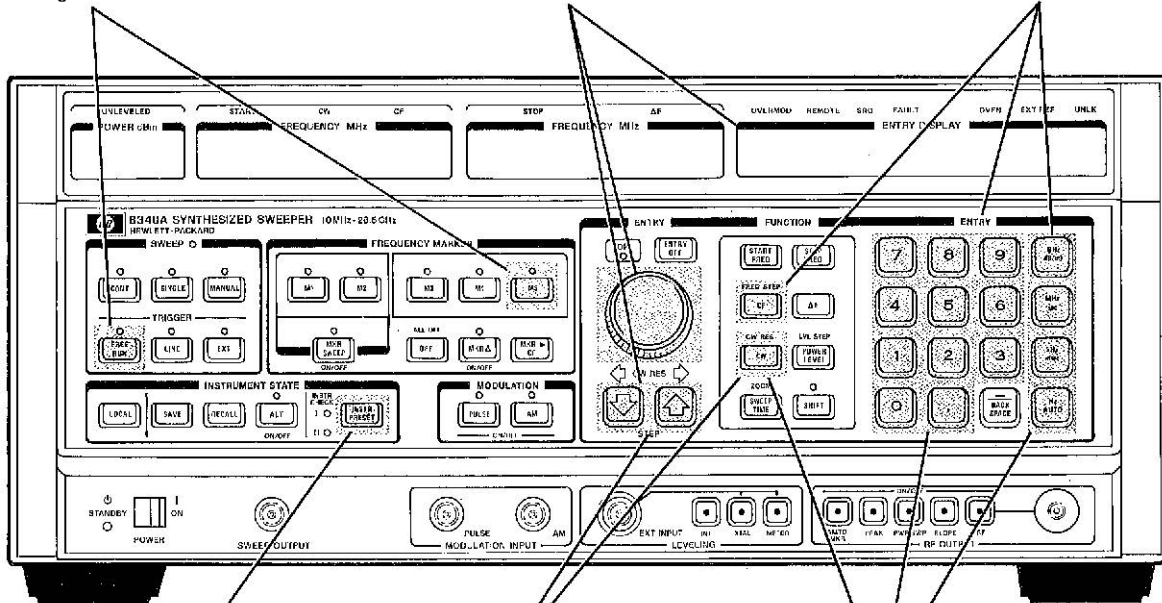

INSTRUMENT PRESET
Restores standard conditions.

KNOB sensitivity:
1. Press **SHIFT, CW**.
2. Use **CW RES** keys to change sensitivity.
3. Press **CW** to return to CW mode.

CW Operation:
1. Press **CW**.
2. Enter value.
3. Select frequency unit.

To get the desired CW frequency, press **[CW]**, then use the numeric keypad to enter your desired CW frequency, followed by the frequency unit (GHz, MHz). The frequency units (GHz, MHz, kHz, Hz) are on keys located to the right of the numeric keys. Try this example:

[CW] [345.123456] [MHz]

Check the **ENTRY DISPLAY** in the upper right hand corner of the instrument, and the left **FREQUENCY MHz** display, which will both show **CW: 12345.123456 MHz** (the **ENTRY DISPLAY** always shows the most recently changed function, which in this case is the CW frequency). Notice that this microwave signal has a resolution at the Hz level!

Try other CW frequencies in the 10 MHz to 26.5 GHz range. As you will see below, the CW frequency can be "tweaked" by using the **[UP]** keys and the **[DOWN]**, but first save this CW configuration for future recall. Press **[PRESET]**, then **[M5]** to save this CW instrument configuration in memory register 1.

STEP KEYS, KNOB

The **[STEP]** keys and the **[KNOB]** affect the function that is currently being displayed in the **ENTRY DISPLAY** window. When you were entering CW frequencies in the last example, your keystrokes were being displayed in the **ENTRY DISPLAY** window and you could have used the **[STEP]** keys or **[KNOB]** to control the CW frequency as well.

For example, enter the following:

[STEP] [10] [MHz]

The **ENTRY DISPLAY** will show this value in MHz. Now alternately press the up-arrow and down-arrow **[UP]** keys while watching the frequency change in the **ENTRY DISPLAY** window. Press and hold one of the **[STEP]** keys for a repeat action.

Next, alternately rotate the **[KNOB]** clockwise and counter-clockwise while watching the changing CW frequency in the **ENTRY DISPLAY**. The **[KNOB]** is

usually used as a fine-sensitivity adjustment, with the **RES** keys used as a coarse adjustment.

To change the sensitivity of the **RES**, press **RES** then **RES**, which will activate the CW RES function. The flashing cursor in the ENTRY DISPLAY indicates the digit affected by the **RES**. Change the resolution by pressing the **RES** key below the **CW RES** label. After you have positioned the flashing cursor over the desired digit, press **RES** to remove the cursor and return to CW mode. Try the **RES** to see the effects of your sensitivity adjustment.

To change the sensitivity of the **RES** keys, press **RES** then **RES**, which will activate the FREQ STEP function (as labeled above the CF key). "STEP" will appear in the ENTRY DISPLAY. Enter the frequency step size you want, using the numerical keys, or the **RES**, or the **RES** keys (which are in a 1-2-5 sequence), followed by a unit key (GHz, MHz, KHz, Hz). When you are finished, press **RES** to return to CW mode, and try the **RES** keys to see the effects of your adjustment.

The **RES** sensitivity you just set will also be the step size for the **RES**, **RES**, **RES** frequency keys, as well as markers **RES-1**. All of these keys are described in this Getting Acquainted guide.

After setting a CW frequency, you will probably want to adjust the power level, which is described below.

POWER LEVEL

The power level, in dBm, is set by a procedure that is very similar to the CW frequency procedure. The HP 8340A can output leveled power for CW or swept frequency operation, or a power sweep. The basic power level adjustment is described here.

To set the power level, press the **POWER LEVEL** key, then use the numeric keys to enter any desired power level, followed by the terminator key **RES**. The minus (-) sign key is also labeled BACK SPACE; The HP 8340A knows that this key is a minus key when used first in a keystroke sequence, and a back space key at all other times.

The selected power level can range from the minimum level of -90 dBm, to the maximum level allowed, which varies with frequency (see the specifications). For practice, enter the following:

POWER LEVEL 12.000 RES

ENTRY DISPLAY will show the selected power level, while the actual power is displayed in the POWER dBm window. If the selected power is

beyond the range of the HP 8340A, the closest possible power will be shown in the POWER dBm display.

When the power level is shown in the ENTRY DISPLAY, the power level can be controlled by the **RES** and **RES** keys. The **RES** affects the power level at the best possible sensitivity, which is 0.05 dBm, while the sensitivity of the **RES** keys can be changed with the LVL STEP function.

To activate the LVL STEP function, press **RES** then the **POWER LEVEL** key (notice the label LVL STEP above the **POWER LEVEL** key). Then use the numerical keypad, or the **RES**, or the **RES** keys (which have a 1-2-5 sequence) to set your desired power step size, followed by the **RES** terminator key. Press the **POWER LEVEL** key to return to POWER LEVEL mode, then try the **RES** keys to see the effects of your adjustment.

So far, you have set a fixed (CW) frequency and a fixed power level. Now you will set sweep operations, first with a power level sweep, then with frequency sweeps.

POWER SWEEP

The HP 8340A can sweep the output power over a 30 dB range. To prepare for this power sweep example, enter the following:

RES 12.000 RES
POWER SWEEP 10.000 RES

The HP 8340A is outputting a 12 GHz CW frequency, and with further instructions will perform power sweeps having a 10 second period. Next, press **RES**, then **RES** which will show the ATN (attenuator) and ALC (automatic leveling control) values in the ENTRY DISPLAY.

The HP 8340A uses the ATN as the coarse adjustment (10 dB steps), and the ALC as the fine adjustment (0.05 dB steps) when you use the **RES** key to set a fixed output power. However, for a maximum-range power sweep the ALC must be decoupled from the ATN, which you just did by pressing **RES** **RES**. After decoupling, the ATN and ALC can be set independently.

Use the **RES** keys to change the ATN value (the clicking sound you hear is the attenuator pads being mechanically switched into place). The ATN value can range from 0 dB to -70 dB, in 10 dB steps. Set the ATN to -40 dB for this example.

SINGLE sweeps
Started when this key is pressed.

Power Level Step Size (STEP keys increment):

1. Press SHIFT, POWER LEVEL.
2. Enter value.
3. Press dB(m).

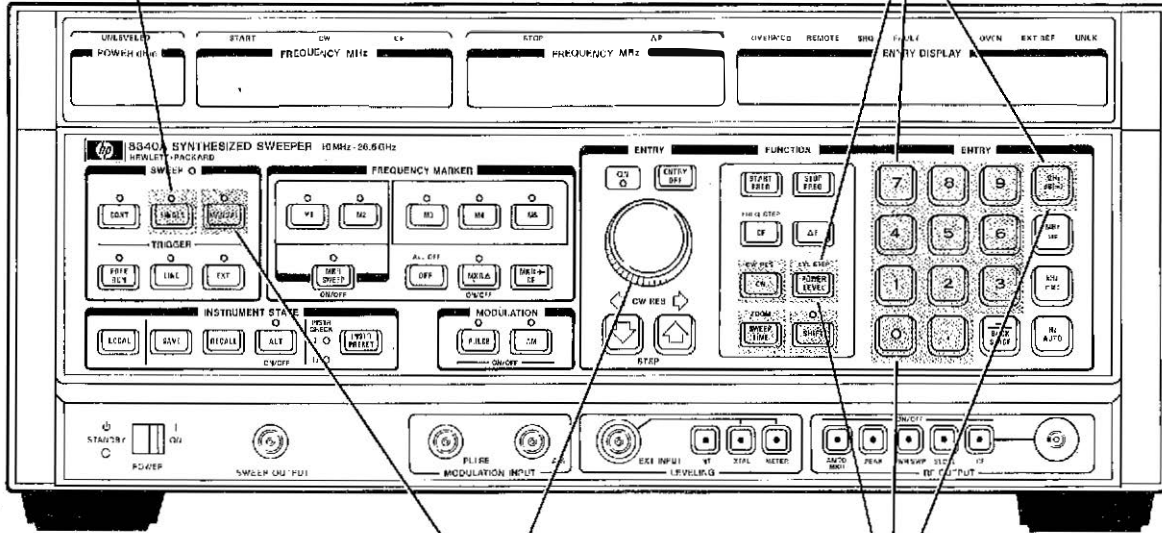

MANUAL sweeps
Controlled by the rotary KNOB.

POWER LEVEL:
1. Press POWER LEVEL.
2. Enter value.
3. Press dB(m).

Next, rotate the **[ROTA]** as you watch the ALC value change. The range is -20 dBm for the lowest value, to an upper value that depends on frequency (see the specifications; the specified upper value is $+10$ dBm at 12 GHz). The maximum effective upper value is determined by watching the POWER dBm display (which shows the ATN + ALC sum) as you increase the ALC value: The red UNLEVELED annunciator will light when you exceed the maximum value. The maximum range of your power sweep equals the maximum leveled range of the ALC, with the ATN providing a fixed offset.

Set the ALC to -15 dBm for this example, using the **[ROTA]** or the numeric keys (with the **[TER]** terminator key). The POWER dBm display will show -55 (-40 ATN plus -15 ALC), and the power sweep range can be at least 25 dB (ALC range of -15 to $+10$ dB).

The rest is easy. Press **[ROTA]**, and the ENTRY DISPLAY will display 0.00 dB/SWP. Use the **[ROTA]** keys, or the **[NUM]**, or the numerical keys (with the

[TER] terminator key) to change this to the desired sweep range. For this example, press



and the HP 8340A will power sweep from -55 dBm to -30 dBm, in a 10 second period.

Before leaving the power sweep function, there are two more keys you should try. Press **[SINGL]** to change from CONTINUOUS sweeps to single sweeps, which start every time you press the **[ROTA]** key (if you press **[ROTA]** in the middle of a sweep, the sweep will stop). Next, press **[MAN]** which will allow you to use the **[ROTA]** to manually sweep through the -55 to -30 dBm range.

Press **[OFF]** again to turn power sweep off, and press **[RECOUPL]** to re-couple the ATN and ALC. Swept frequency operation is explained in the next section.

SWEPT OPERATION

The HP 8340A can sweep a frequency span as large as 26.49 GHz (10 MHz to 26.5 GHz range), or as small as 100 Hz, with 5 frequency markers available to you in the sweep span.

In this Getting Acquainted section, you will be introduced first to establishing swept operation using start/stop frequencies and center/Δ frequencies, followed by marker operations.

START/STOP SWEPT OPERATION

The HP 8340A will sweep from a selected start frequency to a selected stop frequency. To begin, press the **FREQ** key, then enter the numerical value of your desired start frequency, followed by the appropriate frequency unit (GHz, MHz); for example:

3.5 GHz

Then, press the **STOP** key, enter your desired stop frequency followed by the frequency unit; for example:

4.5 GHz

The left FREQUENCY MHz display will show your start frequency, while the middle FREQUENCY MHz display (and ENTRY DISPLAY) will show your stop frequency.

Next, adjust the sweep time. In typical applications the sweep time can vary tremendously — from milliseconds in a network analyzer system to more than a minute in thermistor-based power meter systems. However, the sweep time adjustment procedure is the same: Press the **SWEEP** key, then a numerical value followed by **SEC** or **MSEC**. If the fastest possible sweep time is desired, press **SWEEP** followed by **MIN**. For example, enter the following:

10.00 MSEC

Watch the green LED next to the SWEEP label, which will blink every 2.5 seconds. The LED will blink at each retrace, and at each bandcrossing for wideband sweeps (although you aren't crossing any bands in this example). Next, press **STOP**, then **SWEEP** to obtain the fastest possible sweep speed at this frequency span (10.00 msec).

Press **SAVE**, then **2** to save this start/stop example in storage register 2 for later use.

CENTER FREQUENCY, Δ FREQUENCY SWEPT OPERATION

This is another way of establishing Swept operation. Start/stop swept operation and center/Δ frequency swept operation are just two different ways of defining the sweep limits.

As an example of the CF/Δ F mode, press **CF/Δ F**, a numerical value for the desired center frequency, and the frequency unit (GHz, MHz); for practice try:

3.5 GHz

Then press the **SPAN** key, a numerical value for the span frequency, and the frequency unit; for example:

1.0 GHz

The HP 8340A is now sweeping from 3.5 — 4.5 GHz. The left FREQUENCY MHz display shows your center frequency, while the middle FREQUENCY MHz display (and the ENTRY DISPLAY) shows your delta frequency.

While **CF/Δ F** is the active function (presently being displayed in ENTRY DISPLAY), try the **STOP** and **SWEEP** keys and watch the changing frequency. This symmetrical expansion of the frequency span about the center frequency is one reason that CF/Δ F swept mode is sometimes used instead of start/stop frequency sweeps. Next, you will add markers to the sweep field.

Press **MARK**, then **1** to save this instrument configuration for future recall.

FREQUENCY MARKERS

The HP 8340A has 5 frequency markers that can be used as fixed frequency "landmarks", or as variable frequency pointers on a CRT display. Your introduction to frequency markers will be made by continuing with the previous swept frequency examples.

To obtain the instrument configuration used in the start/stop swept frequency example, press **RECALL** then **2**, which will recall all of the instrument settings that you previously established and SAVED in storage register 2. The HP 8340A should once again be sweeping from 144 MHz to 146 MHz, with a 10.00 msec sweep speed. Add a marker to this sweep field by pressing **MARK**, then enter **144.5 MHz**. This causes an intensified dot to appear at that frequency on a CRT display (to obtain a "spike" at that frequency instead of the intensified dot, press **MARK**).

MARKERS:

1. Press one M1-M5 key.
2. Enter value.
3. Select frequency unit.

MARKER DELTA:

1. Press MKR Δ .
2. Press any two markers M1-M5.
3. Read frequency difference in ENTRY DISPLAY.

START/STOP FREQUENCY SWEEPS:

1. Press START FREQ.
2. Enter value.
3. Press freq unit.
4. Press STOP FREQ.
5. Enter value.
6. Press freq unit.

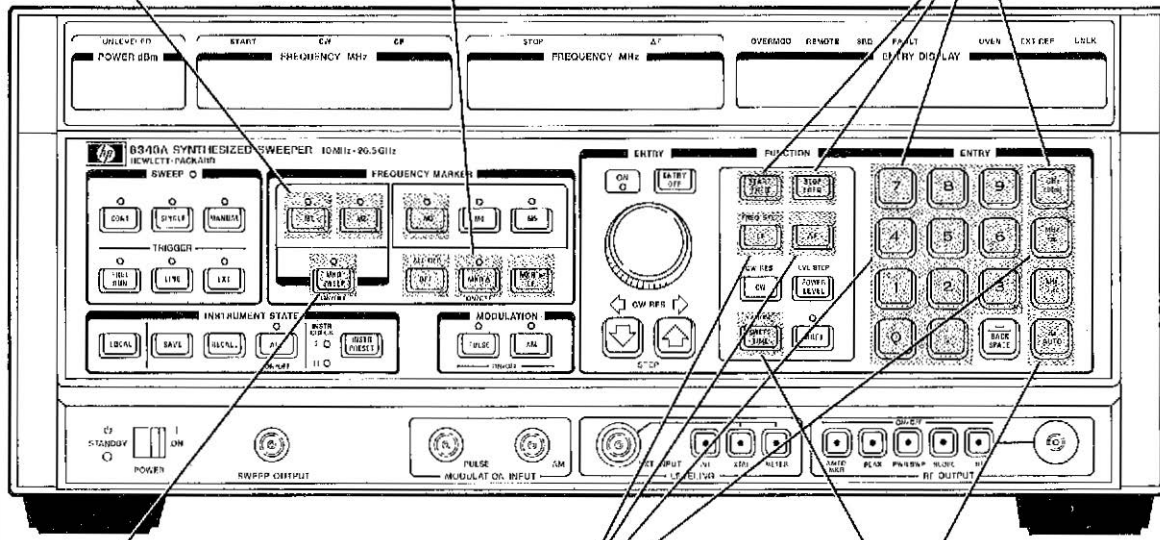

MARKER SWEEP
Press MKR SWEEP.
HP 8340A will sweep between M1-M2.

CF/ Δ F SWEEPS:

1. Press CF.
2. Enter value.
3. Select frequency unit.
4. Press Δ F.
5. Enter value.
6. Select frequency unit.

SWEEP TIME:

1. Press SWEEP TIME, then AUTO to get fastest possible sweep.
or
1. Press SWEEP TIME.
2. Enter value.
3. Press set or msec.

For a second marker, press [M2], then enter [value]. This process can be continued for all 5 markers. Note that the marker presently being displayed in the ENTRY DISPLAY window is "active" and as such can be controlled by the numerical keyboard, [M1-M5], and [M] keys; pressing any marker key will make that marker the active one.

As an example of the marker delta function, press [M1], enter [value], and press [M2]. This causes the frequency difference between any two markers to be displayed in the ENTRY DISPLAY window, and the CRT trace is intensified between the two markers. Select the two markers by pressing any two marker keys. For example, press [M1] [M2], then [M1] [M2], and finally [M1] [M2] and watch the ENTRY DISPLAY for the frequency

differences. Press [M1] again to turn off the [M] function. [M] is a useful aid in examining CRT traces as for example, in measuring the 3 dB bandwidth of a bandpass filter on a network analyzer display.

Once the [M1] and [M2] markers have been established, the Marker Sweep function will change the start/stop frequencies originally established to the frequencies of these two markers. This can serve as a "magnification" function that you can use to focus in on a selected portion of the CRT trace. As an example, press [M1] [M2], which will change the start/stop sweep frequencies to the frequencies of markers [M1] and [M2] (marker sweep works only with [M1] and [M2]). Press [M1] [M2] again to turn off the Marker Sweep function and return the sweep to its previous start/stop limits.

Markers are also used in exactly the same way with CF/ Δ F frequency swept mode, so at this point press **MARKER**, then **SHIFT** to recall the CF/ Δ F swept mode settings stored in register 3 to continue with the marker examples. The HP 8340A should once again be sweeping around a 4 GHz center frequency.

Markers are very easy to use, especially if you let the **MARKER** do the work for you. Try this example: Press **MARKER** and **MARKER** to turn off all markers (so you are starting with a clean slate), then press **MARKER**. **MARKER** will come up with its most recent frequency; however, at the first turn of the **MARKER** the frequency of **MARKER** will jump to the center frequency of the current sweep; that is, if **MARKER** came up at 144.5 MHz it will jump to 4.0 GHz as soon as the **MARKER** is turned. The 4 other markers can be brought into the sweep field in the same manner.

The final example of using markers is **MARKER**, which changes the center frequency of the sweep to the frequency of one of the markers, which is another way of focusing in on a selected portion of the CRT trace. First, press one of the marker keys (the one that you want to become the center frequency) to bring that marker into the ENTRY DISPLAY. Then,

press **MARKER** to change the center frequency to the marker frequency. You can re-use the marker that just became the center frequency.

Markers are indispensable for swept frequency measurements, so practice with them until you are completely comfortable with their many features.

RECALL INSTRUMENT CONFIGURATIONS

For the final Local Operation example, you will recall all of the instrument modes you previously created and saved (with the **MARKER** key) by using the **MARKER** key.

To recall any previously stored instrument configuration (stored by using the **MARKER** key), Press **MARKER**, then the number of the storage register (1 - 9). For example:

MARKER 0 recalls the CW configuration used in this Getting Acquainted guide.

MARKER 0 recalls the start/stop sweep example used in this guide.

SAVE n

Stores instrument state in register n (1-9).

RECALL n

Recalls instrument state previously SAVED in register n (1-9).

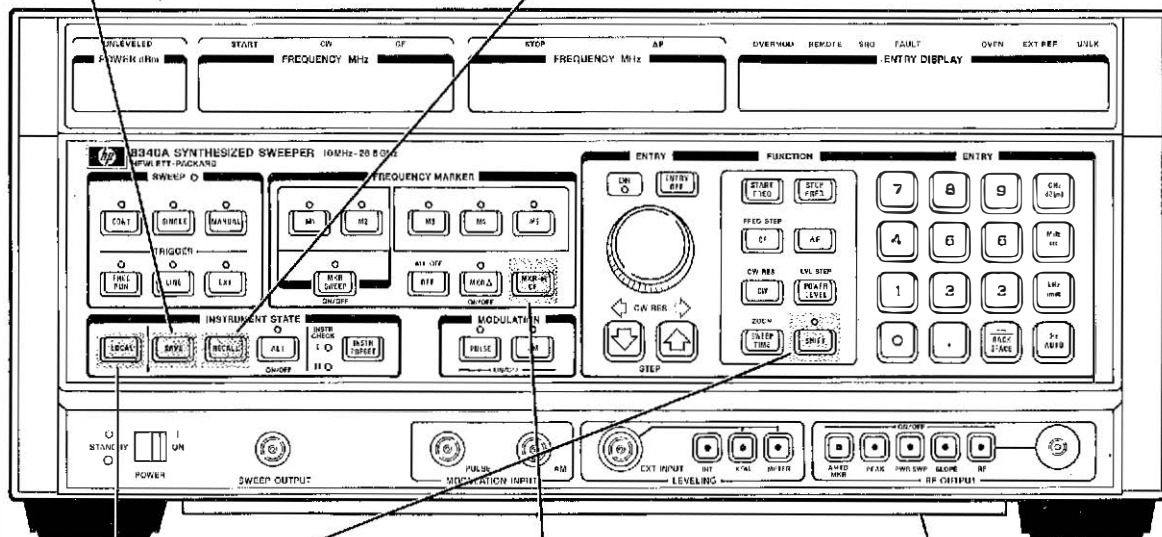

SHIFT, LOCAL

Causes the HP-IB address to appear in the ENTRY DISPLAY.

MKR → CF:

1. Press one marker M1-M5.
 2. Press MKR → CF.
- The center sweep frequency (CF) will change to the frequency of the marker.

Information Cards

Summarize operation procedures.

recalls the center frequency / Δ frequency example.

This completes the basic introduction to local (front panel) operation of the HP 8340A Synthesized Sweeper. At this point, you are ready to study (as

needed) the advanced features of Local Operation contained in Section III of the HP 8340A Operating and Service Manual.

An introduction to remote (computerized) operation of the HP 8340A is provided in the following text.

REMOTE OPERATION OF THE HP 8340A SYNTHESIZED SWEEPER

HP-IB Interface Cables Available

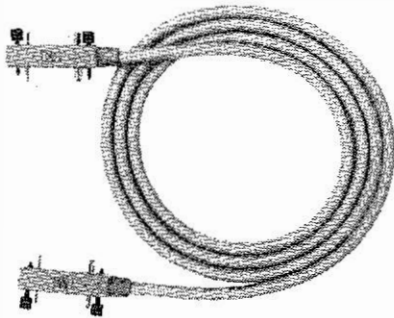

| HP-IB Cable Part Numbers | Lengths |
|--------------------------|-----------------|
| HP 10833A | 1 m (3.3 ft.) |
| HP 10833B | 2 m (6.6 ft.) |
| HP 10833C | 4 m (13.2 ft.) |
| HP 10833D | 0.5 m (1.6 ft.) |

HP-IB CONNECTION

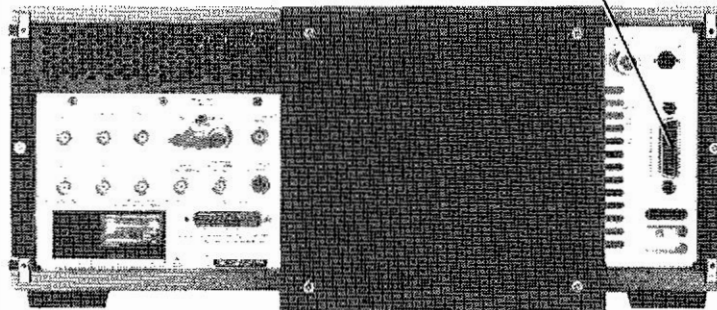

PREPARATION FOR USE

Prepare the instruments for remote operation by connecting an HP-IB cable between the computer and the HP 8340A, and load the BASIC operating system into the computer (if necessary).

Any HP-IB computer system can control the HP 8340A; however, for simplicity only HP BASIC language commands will be used in this Getting Acquainted section. These BASIC commands are applicable to the HP 9826, 9835, 9836, 9845, and HP 80-series of computers. For other computers and other languages, consult Section III of the HP 8340A Operating and Service Manual, and the computer manuals.

Next, check the HP-IB address of the HP 8340A. If several instruments are connected to an HP-IB cable, each must have a unique address within the range of 00-30. The factory-set address for the HP 8340A is 19, which can be seen in one of two ways: Flip the STANDBY/ON switch from STANDBY to ON, and the HP-IB address will appear (momentarily) in the ENTRY DISPLAY; or press MODE , then ENTER , which will also cause the address to appear in the ENTRY DISPLAY.

To change the HP-IB address, press **19**, a numerical value (range 00–30), and any “terminator” key (GHz, MHz, kHz, Hz). The examples that follow use “19” as the HP 8340A address.

PREPARATORY COMPUTER COMMANDS

HP-IB systems can be very complicated, with several instruments and lots of activity on the bus. Although your simple practice setup (one computer, one instrument) doesn't require any preparatory commands, the following 3 commands are so useful that you should become familiar with them at this time.

The “panic button” for an HP-IB system is the ABORT command. All activity on the bus is halted by this command:

ABORT 7

Enter this statement on the computer, then press the computer's **7** or **7** key. All HP-IB instruments (“7” directs the command to the HP-IB system) have stopped transmitting on the HP-IB and are now listening for a command from the controller (computer).

Now you want to specifically tell the HP 8340A that the computer is in command, not the front panel. To change the HP 8340A from local (front panel) control to remote HP-IB operation, enter this command:

REMOTE 719

followed by pressing the **7** or **7** key. This command prepares the HP-IB (code “7”) instrument located at address 19 for computer control. Notice that the amber REMOTE annunciator above the ENTRY DISPLAY is now lighted. Also notice that the front panel controls on the HP 8340A no longer function, except for the **7** switch and the **7** key (pressing the **7** key will return front panel control to the HP 8340A).

As the final preparatory command, enter

CLEAR 719

followed by **7** or **7**, as usual. This command clears the internal status byte and extended status byte registers of the HP 8340A, so you start with a “clean slate” before beginning a program. None of the front panel annunciators change when you execute this command. This completes the preparatory commands.

At this point, any front panel function (and several special functions) can be controlled by the computer. However, only a few commands will be pre-

sented in this Getting Acquainted guide — just enough to get you started. After this introduction, you will be prepared for the additional material contained in the Programming Notes and Operating Guides contained in Section III of the HP 8340A Operating and Service Manual.

DATA COMMANDS, OUTPUT

Data commands change the operating conditions of the HP 8340A, and are typically the most often used commands in remote applications. All front panel keystroke operations can be replaced by a data command (except for the **7** switch). The format for outputting data commands is

OUTPUT 719; “CODE”

for the simplest commands, or

OUTPUT 719; “CODE DATA TERMINATOR”

for the commands that require numerical data. In both cases, the statements are followed by **7** or **7**. CODE is the characters that represent a front panel key, or a special function; all codes are listed on the lower Information Card (located below the front panel of the HP 8340A). DATA is the numerical value that is desired, and TERMINATOR is the desired unit (such as GHz, sec, dB(m), etc.). The TERMINATOR abbreviations are also listed on the Information Cards. Try each of the following commands as they are explained to you.

The simplest commands involve no numerical data. For example, Instrument Preset is established by this command:

OUTPUT 719; “IP”

For shifted commands, add SH; for example

OUTPUT 719; “SHT1”

starts the display self test, and

OUTPUT 719; “SHM5”

stops the display test. A complete code-data-terminator command for establishing a 12 GHz CW output is written:

OUTPUT 719; “CW12GZ”

The commands you have tried so far have had one command per statement; however, the commands can be strung back-to-back in the same statement. For example

OUTPUT 719; “CW12GZPL-50DB”

causes the HP 8340A to output a 12 GHz CW signal at a power level of -50 dBm.

The HP 8340A ignores spaces and unassigned characters that are placed in a command string, and automatically upshifts lower-case letters. Therefore, both of the following commands are functionally equivalent (although the statement with spaces requires a longer execution time):

```
OUTPUT 719; "FA8GZFB12GZPL0DBST500MS"
```

```
OUTPUT 719; "FA 8 Gz  FB 12 Gz  PL 0 dB  
ST 500 mS"
```

The second statement is easier to read and check for errors. Looking at the Information Cards, the above statement translates to start frequency (FA) of 8 GHz, stop frequency (FB) of 12 GHz, power level (PL) of 0 dBm, and a sweep time (ST) of 500 milliseconds (mS).

There is also a command, **EK**, that is added to another code to enable KNOB control of that function on an otherwise remote front panel. For example:

```
OUTPUT 719; "EKFA" enables KNOB control of the  
start frequency
```

```
OUTPUT 719; "EKFB" enables KNOB control of the  
stop frequency
```

```
OUTPUT 719; "EKPL" enables KNOB control of the  
power level
```

This completes the introduction to sending data from the computer to the HP 8340A; but how do you send data from the HP 8340A to the computer (the reverse operation)?

DATA COMMANDS, INPUT

A set of commands allows the computer to read HP 8340A conditions — such conditions as the start frequency, the power level, sweep times and many others. As an example, enter the following program, which will set and read the start frequency of the HP 8340A:

```
10 REMOTE 719  
20 OUTPUT 719; "FA 100 Mz  FB 200  Mz  
PL -50 dB"  
30 OUTPUT 719; "OPFA"  
40 ENTER 719; A  
50 DISP A; " MHz start frequency"  
60 END
```

Press **ENTER** on the computer. The HP 8340A will start sweeping at 100 MHz (FA 100 Mz), stop sweeping at 200 MHz (FB 200 Mz), at a power level of -50 dBm (PL-50 dB). The command **OPFA** in line 30 translates as "Output Interrogated Parameter" (OP) the "Start Frequency" (FA). The value of the start frequency (the interrogated parameter) is placed in a buffer, and transferred to the computer's variable A in line 40 (A is an arbitrary selection; any floating point variable can be used).

To read the stop frequency and the power level, modify the previous program from line 50 and beyond as follows:

```
50 OUTPUT 719; "OPFB"  
60 ENTER 719; B  
70 OUTPUT 719; "OPPL"  
80 ENTER 719; C  
90 DISP A; " MHz start "; B; " MHz stop "; C; " dBm  
power level"  
100 END
```

Press **ENTER** and the start frequency (variable A), stop frequency (variable B), and power level (variable C) will be set by the computer and the values will be displayed on the computer's screen.

This completes the introduction to remote operation of the HP 8340A. Although only a few examples were presented, you will find that most of the other programming commands follow a very similar format, and they will be easy to learn after this introductory practice.

This also completes the Getting Acquainted guide. You should now be ready to study (as needed) the advanced features discussed in Section III of the HP 8340A Operating and Service Manual.



For more information, call your local HP Sales Office or nearest Regional Office: Eastern (201) 265-5000; Midwestern (312) 255-9800; Southern (404) 955-1500; Western (213) 970-7500; Canadian (416) 678-9430. Ask the operator for instrument sales. Or write Hewlett-Packard, 1501 Page Mill Road, Palo Alto, CA 94304. In Europe: Hewlett-Packard S.A., 7, rue du Bois-du-Lan, P.O. Box, CH 1217 Moirin 2, Geneva, Switzerland. In Japan: Yokogawa-Hewlett-Packard Ltd., 29-21, Takaido-Higashi 3-chome, Suginami-ku, Tokyo 168.

HP Part Number 08340-90040

Printed in U.S.A.

OPERATING INFORMATION

8340A SYNTHESIZED SWEEPER

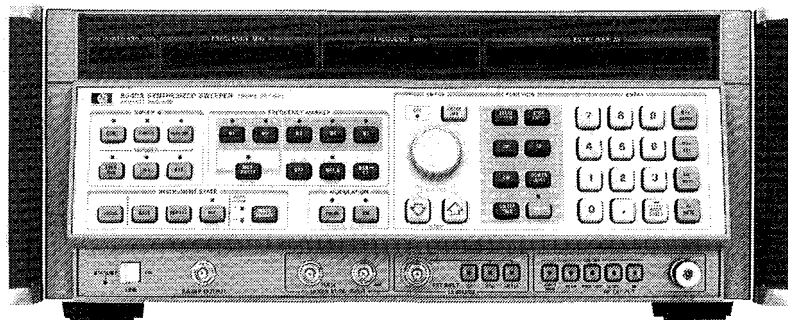

 **HEWLETT
PACKARD**

HP 8340A SYNTHESIZED SWEEPER Operating Information

© Copyright HEWLETT-PACKARD COMPANY 1983
1400 FOUNTAINGROVE PARKWAY, SANTA ROSA, CA 95401 U.S.A.

HP 8340A Synthesized Sweeper Operating and Service Manual

| | |
|---|----------------------------|
| Operating and Service Manual (includes Sections I through VIII) | HP Part Number 08340-90020 |
| Operating and Service Manual Microfiche (includes Sections I through VIII)... | HP Part Number 08340-90021 |
| Operating Manual..... | HP Part Number 08340-90022 |

Printed: DECEMBER 1983



SECTION III OPERATION

INTRODUCTION

This section completely describes all front- and rear-panel keys, connectors, switches, and displays of the HP 8340A Synthesized Sweeper, and explains all code mnemonics and the procedures used for HP-IB programming. Also described are enhancement procedures for the power control and modulation functions.

The descriptive material in the local operation subsection is organized according to the physical layout of the HP 8340A. To find specific information, use as an index either Table 3-1, or Figures 3-1 and 3-2:

Table 3-1 lists the operational modes and functions of the HP 8340A, shows the keystrokes that initiate those functions, and lists the reference figures that explain the procedures.

Figure 3-1 is a front panel drawing of the HP 8340A, with callouts indicating the reference figures that explain each key, connector, switch, and display.

Figure 3-2 is a rear panel drawing of the HP 8340A, with callouts that indicate the appropriate reference figures.

The nucleus for the HP-IB programming material is Table 3-2. Table 3-2 lists all code mnemonics and provides cross referencing to equivalent front panel keys. The codes that do not have an equivalent front panel key, along with the HP-IB programming procedures, are explained following Table 3-2.

The power control and modulation functions have several enhancement provisions. These provisions are mentioned in the relevant parts of the local operation and HP-IB programming subsections, but a collective, detailed explanation is made at the end of this Operation section.

A Table of Contents for this section follows this Introduction.

Hewlett-Packard periodically updates the operating information for the HP 8340A, in the form of a Manual Changes Supplement, and publishes a series of Operating Guides and Programming Notes. Contact the nearest HP Sales and Service office (listed inside of the back cover) to obtain this supplemental information as it becomes available.

TABLE OF CONTENTS

INTRODUCTION..... 3-1

LOCAL OPERATING INFORMATION

| Figure | Page |
|--|------|
| 3-1. Index by Front Panel Keys, Display and Connectors | 3-3 |
| 3-2. Index by Rear Panel Connectors | 3-3 |
| 3-3. Power dBm Display..... | 3-7 |
| 3-4. START/CW/CF Frequency Display..... | 3-9 |
| 3-5. STOP/ Δ F Frequency Display..... | 3-10 |
| 3-6. Entry Display | 3-11 |
| 3-7. Function..... | 3-13 |
| 3-8. KNOB/STEP Entry..... | 3-16 |
| 3-9. Frequency Marker | 3-17 |
| 3-10. Entry..... | 3-20 |
| 3-11. Sweep and Trigger | 3-22 |
| 3-12. Instrument State..... | 3-25 |
| 3-13. Power Switch, Sweep Output..... | 3-27 |
| 3-14. Modulation | 3-28 |
| 3-15. Modulation Input..... | 3-29 |
| 3-16. Leveling | 3-30 |
| 3-17. RF Output | 3-32 |
| 3-18. Rear Panel BNC Connectors..... | 3-35 |
| 3-19. Rear Panel RF Output | 3-37 |
| 3-20. HP-IB Connector..... | 3-38 |
| 3-21. HP 8410 Interface..... | 3-40 |
| 3-22. HP 8755C Interface | 3-42 |
| 3-23. Fan Assembly..... | 3-43 |
| 3-24. Power Line Module..... | 3-44 |

| Table | Page |
|---------------------------------------|------|
| 3-1. Index by Mode and Function | 3-4 |

HP-IB PROGRAMMING INFORMATION

| | |
|--|------|
| Introduction | 3-45 |
| Interconnective Cabling | 3-45 |
| Instrument Addresses | 3-45 |
| HP-IB Instruments Nomenclature | 3-45 |
| Programming the HP 8340A | 3-45 |
| HP-IB Command Statements | 3-46 |
| HP 8340A Programming Codes..... | 3-51 |
| Programs that Duplicate Front Panel Operations..... | 3-51 |
| Using the Rotary KNOB..... | 3-56 |
| Using Keys that Toggle ON/OFF | 3-56 |
| Operator's Programming Check | 3-56 |
| Unique HP-IB Programming Codes | 3-57 |
| System Timing | 3-77 |
| HP-IB Programming Techniques for Special Applications..... | 3-77 |
| HP-IB Pin-Out Description..... | 3-78 |
| The Twelve HP-IB Messages..... | 3-81 |
| Computer Access of HP-IB Lines..... | 3-88 |

3-2

| | |
|---|------|
| Sending HP-IB Messages..... | 3-88 |
| Reading HP-IB Messages..... | 3-89 |
| Direct Writing to the HP-IB Lines | 3-91 |

| Figure | Page |
|--|------|
| 3-25. HP-IB Pin-Out | 3-78 |
| 3-26. HP-IB Handshake Timing..... | 3-79 |
| 3-27. Representative Status Registers..... | 3-90 |
| 3-28. Representative Control Registers | 3-92 |

| Table | Page |
|--------------------------------------|------|
| 3-2. HP 8340A Programming Codes..... | 3-53 |
| 3-3. The Standard ASCII Code..... | 3-85 |

POWER CONTROL AND MODULATION INFORMATION

| | |
|--|-------|
| INTERNAL LEVELING | 3-94 |
| Coupled Mode..... | 3-94 |
| Power dBm Display | 3-95 |
| Decoupled Mode..... | 3-96 |
| UNLEVELED MODE | 3-98 |
| EXTERNAL LEVELING..... | 3-100 |
| Detector Characteristics..... | 3-101 |
| POWER dBm Display used with the Attenuator | 3-103 |
| Bandwidth | 3-103 |
| AMPLITUDE MODULATION | 3-105 |
| Power dBm Display used with AM | 3-105 |
| Dynamic Range..... | 3-105 |
| Bandwidth for AM Applications | 3-106 |
| PULSE MODULATION | 3-106 |
| Sample and Hold Leveling | 3-106 |
| Response Time..... | 3-110 |
| Unleveled Mode Used with Pulse Modulation | 3-110 |
| Input Characteristics | 3-111 |
| Pulse Envelope | 3-112 |
| Source Match..... | 3-112 |
| Video Feedthrough | 3-112 |
| FURTHER INFORMATION | 3-113 |

| Figure | Page |
|--|-------|
| 3-29. ALC Loop Block Diagram..... | 3-95 |
| 3-30. Reverse Power Effects | 3-97 |
| 3-31. Typical Unleveled Modulation Response..... | 3-99 |
| 3-32. Typical External Leveling Hookup..... | 3-100 |
| 3-33. Typical Crystal Detector Response at 25°C..... | 3-102 |
| 3-34. Pulse Measuring System..... | 3-108 |
| 3-35. Error Detection and Modulator Drive.. | 3-109 |
| 3-36. Pulse Input Circuit..... | 3-112 |
| 3-37. Video Feedthrough | 3-113 |

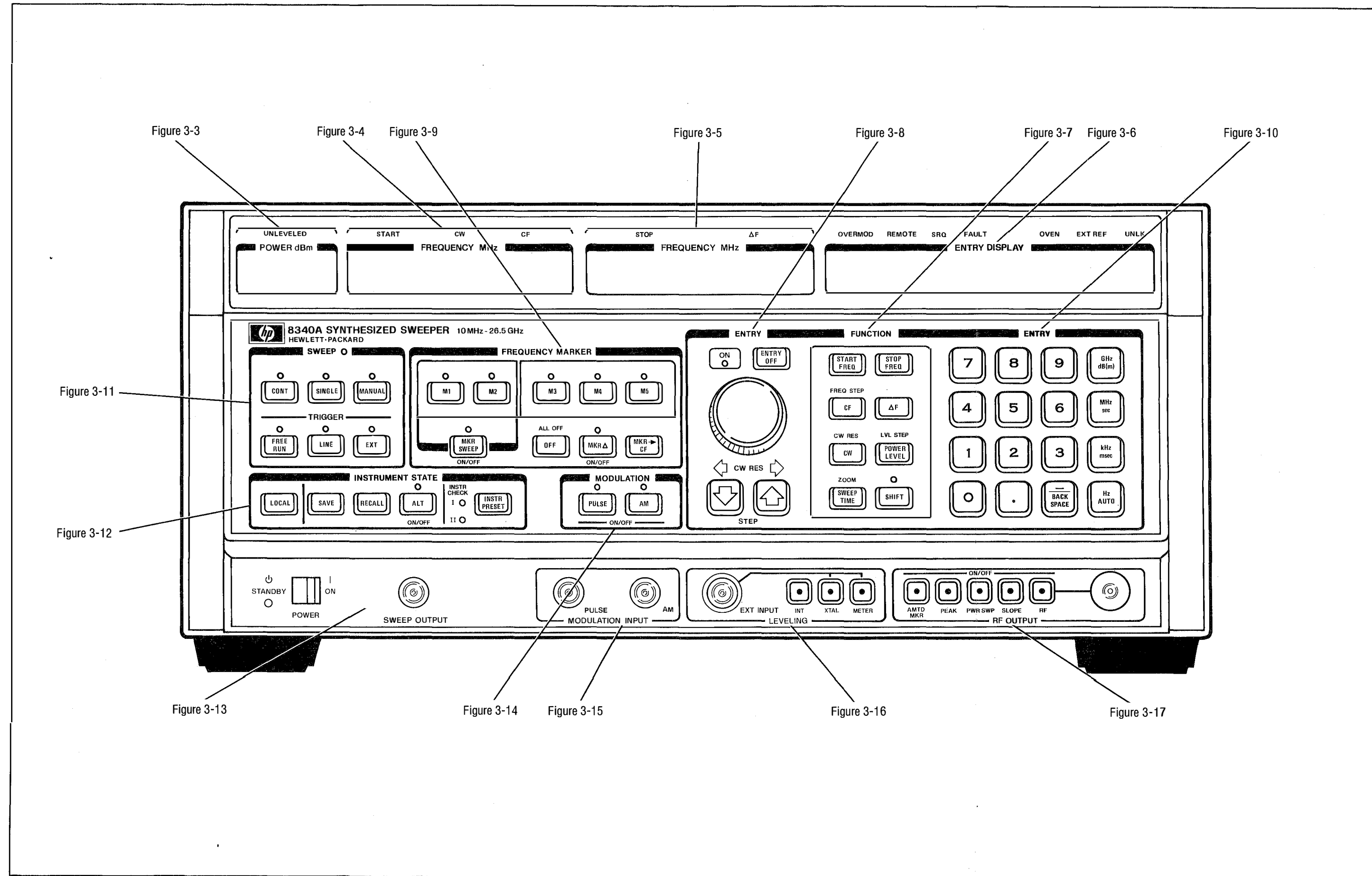

Figure 3-1. Index by Front Panel Keys, Display and Connectors

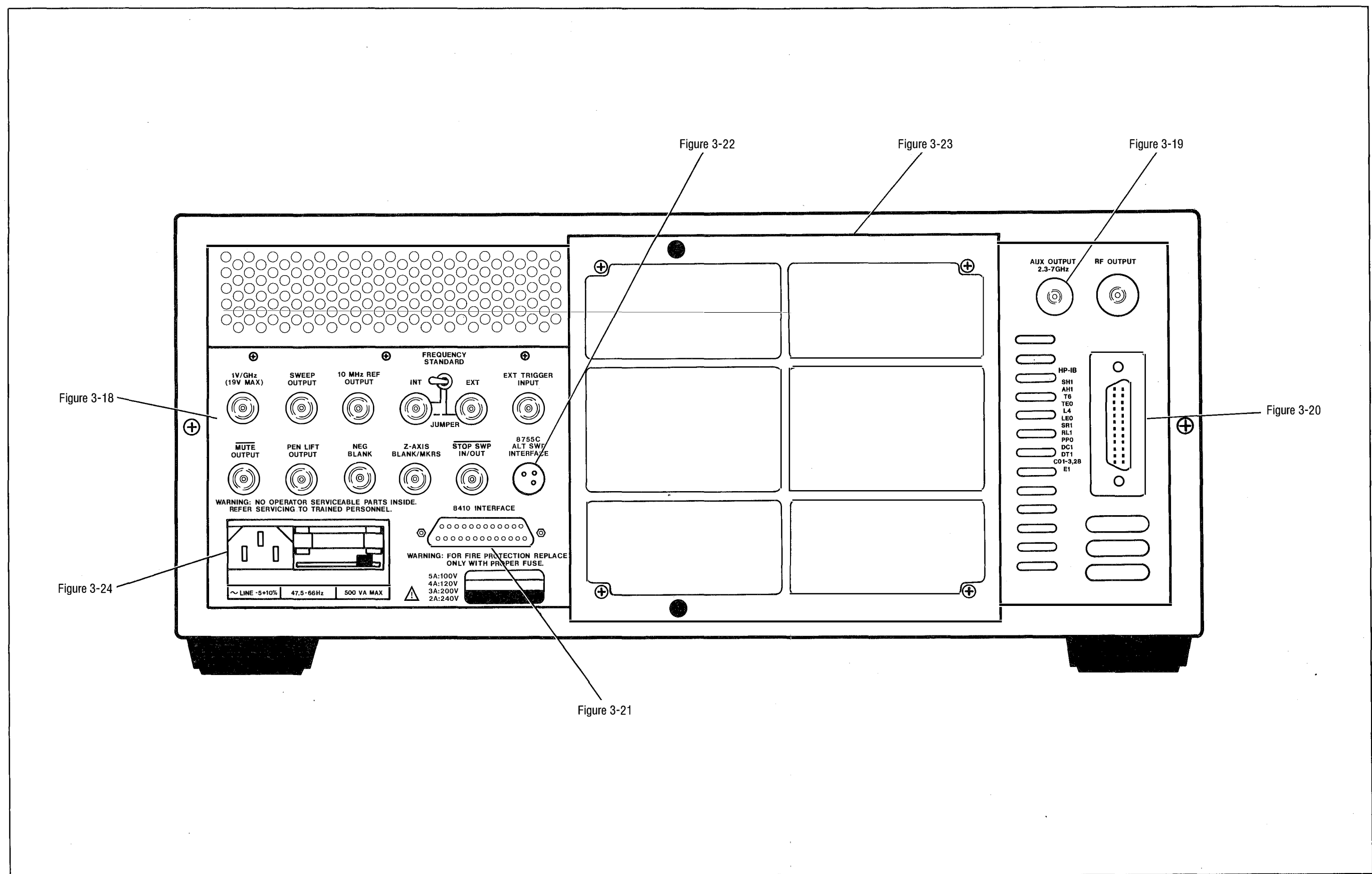

Figure 3-2. Index by Rear Panel Connectors

Table 3-1. Index by Mode and Function (1 of 6)

| Mode | Function | Keys | HP-IB Code | Reference Figure | |
|---------------------------------------|-------------------------------|----------------------|------------|------------------|-----|
| Swept/CW Frequency Selection | | | | | |
| Start/Stop Sweep | START | [START FREQ] | FA | 3-7 | |
| | STOP | [STOP FREQ] | FB | | |
| Center Frequency/ ΔF Sweep | CF | [CF] | CF | | |
| | ΔF | [ΔF] | DF | | |
| | ZOOM | [SHIFT] [SWEEP TIME] | SHST | | |
| CW Frequency | CW | [CW] | CW | | |
| | CW RESOLUTION | [SHIFT] [CW] | SHCW | | |
| Frequency Markers | | | | | |
| Turn On and Set Marker Frequency | MARKER 1 | [M1] | M1 | | 3-9 |
| | MARKER 2 | [M2] | M2 | | |
| | MARKER 3 | [M3] | M3 | | |
| | MARKER 4 | [M4] | M4 | | |
| | MARKER 5 | [M5] | M5 | | |
| Turn Off A Frequency Marker | M1 OFF | [M1] [OFF] | M1M0 | 3-9 | |
| | M2 OFF | [M2] [OFF] | M2M0 | | |
| | M3 OFF | [M3] [OFF] | M3M0 | | |
| | M4 OFF | [M4] [OFF] | M4M0 | | |
| | M5 OFF | [M5] [OFF] | M5M0 | | |
| Turn Off All Markers | ALL OFF | [SHIFT] [OFF] | SHM0 | | |
| Turn On And Set Mkr Δ | MKR Δ, Marker "m" Marker "n" | [MKR Δ] | MD1 | | |
| Turn Off Mkr Δ | MKR Δ OFF | | MD0 | | |
| Active Marker To Center Frequency | MKR → CF | [MKR → CF] | MC | | |
| Marker 1-2 Sweep | MKR SWEEP ON MKR SWEEP OFF | [MKR SWEEP] | MP1 MP0 | | |
| Marker 1 to Start Marker 2 to Stop | M1 → START M2 → STOP | [SHIFT] [MKR SWEEP] | SHMP | | |
| Amplitude Frequency Markers | AMPTD MKR ON | [AMTD MKR] | AK1 | 3-17 | |
| | AMPTD MKR OFF | | AK0 | | |

Table 3-1. Index by Mode and Function (2 of 6)

| Mode | Function | Keys | HP-IB Code | Reference Figure | |
|--|--------------------------------------|-----------------------|-------------|------------------|------------|
| Sweep Mode, Trigger and Time | | | | | |
| Sweep Mode | CONTINUOUS | [CONT] | S1 | 3-11 | |
| | SINGLE | [SINGLE] | S2 or SG | | |
| | MANUAL FREQUENCY SWEEP | [MANUAL] | S3 or SM | | |
| Sweep Trigger | FREE RUN | [FREE RUN] | T1 | | |
| | LINE | [LINE] | T2 | | |
| | EXTERNAL | [EXT] | T3 | | |
| Sweep Time | SWEEP TIME | [SWEEP TIME] | ST | | 3-7 |
| Modulation | | | | | |
| Amplitude Modulation | AM ON | [AM] | AM1 | | 3-14, 3-15 |
| | AM OFF | | AM0 | | |
| Pulse Modulation | PULSE MOD. ON | [PULSE] | PM1 | | |
| | PULSE MOD. OFF | | PM0 | | |
| | INCREASE ALC BANDWIDTH IN PULSE MODE | | SHAM | | |
| Step Size, Display, and Entry Control | | | | | |
| Set Frequency Step Size | FREQUENCY STEP SIZE | [SHIFT] [CF] | SF or SHCF | 3-7 | |
| Set Power Step Size | POWER STEP SIZE | [SHIFT] [POWER LEVEL] | SP or SHPL | | |
| Increment Active Parameter | STEP UP ↑ | [▲] (STEP KEY) | UP | 3-8 | |
| Decrement Active Parameter | STEP DOWN ↓ | [▼] (STEP KEY) | DN | | |
| Numeric Display Update | RE-ENABLE DISPLAY UPDATE | [SHIFT] [CONT] | SHSI or DUI | | |
| X-Y Recorder Interface | ENABLE PENLIFT AT BANDCROSSING | [SHIFT] [LINE] | SHT21 | 3-11 | |
| | DISABLE PENLIFT AT BANDCROSSING | | SHT20 | | |

Table 3-1. Index by Mode and Function (3 of 6)

| Mode | Function | Keys | HP-IB Code | Reference Figure |
|--|---------------------------|----------------------|------------|------------------|
| Step Size, Display and Entry Control (Cont'd) | | | | |
| Fixed Function To Coupled Mode | AUTO | [Hz/AUTO] | AU | 3-10 |
| Disable Active Function | ENTRY OFF | [ENTRY OFF] | EF | 3-8 |
| Display Scale | MULTIPLICATION FACTOR | [SHIFT] [START FREQ] | SHFA | 3-7 |
| Display Offset | OFFSET FACTOR | [SHIFT] [STOP FREQ] | SHFB | |
| Instrument State/Registers | | | | |
| Instrument Preset | INSTR PRESET | [INSTR PRESET] | IP | 3-12 |
| Save An Instrument State | SAVE n | [SAVE] | SV | |
| Recall An Instrument State | RECALL n | [RECALL] | RC | |
| Lock Registers | SAVE LOCK | [SHIFT] [SAVE] | SHSV | |
| Unlock Registers | SAVE UNLOCK | [SHIFT] [RECALL] | SHRC | |
| Alternate Sweep Mode | ALT ON | [ALT] | AL1 | |
| | ALT OFF | | AL0 | |
| Power Level and Control | | | | |
| Set Output Power Level | POWER LEVEL | [POWER LEVEL] | PL | 3-7 |
| Power Sweep Mode | POWER SWEEP ON | [PWR SWP] | PS1 | 3-17 |
| | POWER SWEEP OFF | | PS0 | |
| Power Slope Mode | SLOPE ON | [SLOPE] | SL1 | |
| | SLOPE OFF | | SL0 | |
| RF Power | RF ON | [RF] | RF1 | |
| | RF OFF | | RF0 | |
| Peak Output Power (CW Mode or Manual Sweep) | PEAK ON | [PEAK] | RP1 | |
| | PEAK OFF | | RP0 | |
| Instantaneous Peak | FAST PEAKING | [SHIFT] [AMTD MKR] | SHAK | |
| Tracking Calibration | AUTO TRACKING CALIBRATION | [SHIFT] [PEAK] | SHRP | |

Table 3-1. Index by Mode and Function (4 of 6)

| Mode | Function | Keys | HP-IB Code | Reference Figure |
|---|---|--------------------|-----------------|------------------|
| Power Level and Control (Cont'd) | | | | |
| Leveling Modes | INTERNAL | [INT] | A1 | 3-16 |
| | EXTERNAL CRYSTAL | [XTAL] | A2 | |
| | EXTERNAL POWER METER | [METER] | A3 | |
| | DISABLE ALC TO CONTROL MODULATOR DRIVE DIRECTLY | [SHIFT] [METER] | SHA3 | |
| Independent Control of ALC and Attenuator | DECOUPLE ALC AND ATTENUATOR | [SHIFT] [PWR SWP] | SHPS | 3-17 |
| | CONTROL EACH INDEPENDENTLY | | 1 | |
| | CONTROL STEP ATTENUATOR INDEPENDENTLY | | [SHIFT] [SLOPE] | |
| Diagnostic Functions | | | | |
| Display M/N and 20/30 Loop Frequencies | DISPLAY M,N, M/N FREQ., 20/30 FREQ. | [SHIFT] [M1] | SHM1 | 3-9 |
| Display Band # And Y.O. Loop Frequency | DISPLAY BAND # AND Y.O. FREQ. | [SHIFT] [M2] | SHM2 | |
| Display VCO1 And VCO2 Frequencies | DISPLAY VCO1 | [SHIFT] [M3] | SHM3 | |
| Front Panel Display Test | DISPLAY TEST | [SHIFT] [FREE RUN] | SHT1 | 3-11 |
| Display Unlock | DISPLAY UNLOCK | [SHIFT] [EXT] | SHT3 | |
| Display Fault Indicators | DISPLAY FAULT INDICATORS | [SHIFT] [MANUAL] | SHS3 | |
| Band Cross Control | DISABLE BAND CROSS | [SHIFT] [XTAL] | SHA21 | 3-16 |
| | RE-ENABLE BAND CROSS | | SHA20 | |
| Cause Manual Band Cross | MANUAL BAND CROSS | [SHIFT] [INT] | SHA1 or BC | |
| Turn Off Diagnostic Display | DIAGNOSTICS OFF | [SHIFT] [MS] | SHM5 | 3-9 |

Table 3-1. Index by Mode and Function (5 of 6)

| Mode | Function | Keys | HP-IB Code | Reference Figure |
|-----------------------------------|---------------------------------|---------------------|------------|------------------|
| Read/Write to Internal Circuits | SELECT CHANNEL | [SHIFT] [GHz/dB(m)] | SHGZ | 3-10 |
| | SELECT SUBCHANNEL | [SHIFT] [MHz/sec] | SHMZ | |
| | WRITE DATA | [SHIFT] [KHz/msec] | SHKZ | |
| | READ DATA | [SHIFT] [Hz/AUTO] | SHHZ | |
| HP-IB Functions | | | | |
| Status Bytes and Service Requests | CLEAR BOTH STATUS BYTES | | CS | |
| | OUTPUT BOTH STATUS BYTES | | OS | |
| | MASK STATUS BYTE 1 | | RM | |
| | MASK STATUS BYTE 2 | | RE | |
| Output Operating Configuration | OUTPUT LEARN STRING | | OL | |
| | INPUT LEARN STRING | | IL | |
| | OUTPUT MODE STRING | | OM | |
| Output Parameters | OUTPUT ACTIVE VALUE | | OA | |
| | OUTPUT NEXT BANDCROSS FREQUENCY | | OB | |
| | OUTPUT COUPLED PARAMETERS | | OC | |
| | OUTPUT DIAGNOSTICS | | OD | |
| | OUTPUT FAULTS | | OF | |
| | OUTPUT FIRMWARE ID | | OI | |
| | OUTPUT LAST LOCK FREQUENCY | | OK | |
| | OUTPUT INTERROGATED PARAMETER | | OP | |
| OUTPUT POWER LEVEL | | OR | | |

Table 3-1. Index by Mode and Function (6 of 6)

| Mode | Function | Keys | HP-IB Code | Reference Figure |
|---------------------------|-----------------------------------|------|------------|------------------|
| Network Analyzer Function | NETWORK ANALYZER CONFIGURE | | NA | |
| | ADVANCE TO NEXT BANDCROSSING | | BC | |
| | KEYBOARD RELEASE | | KR | |
| | SWAP CHANNELS | | SW | |
| Control Knob | ENABLE HP 8340A KNOB | | EK | |
| | ENABLE REMOTE KNOB | | RB | |
| Sweep Functions | STEPPED SWEEP | | SN | |
| | INCREMENT FREQUENCY | | IF | |
| | RESET SWEEP | | RS | |
| | TAKE SWEEP | | TS | |
| | TIME LIMIT | | TL | |
| Alternate State Selection | SELECT FOREGROUND | AS0 | | |
| | SELECT BACKGROUND | AS1 | | |
| Fast Phaselock | FAST PHASELOCK SELECT | FP | | |
| Attenuator Control | INDEPENDENT CONTROL OF ATTENUATOR | AT | | |
| HP-IB Test | TEST HP-IB DATA TRANSMISSION | TI | | |

DESCRIPTION

This display shows the actual power delivered to the RF OUTPUT port of the HP 8340A, and contains the UNLEVELED warning indicator.

PANEL LAYOUT

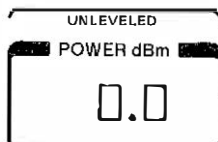

FUNCTIONS

POWER dBm: The available output power of the HP 8340A is shown in this display, rounded to the nearest 0.1 dB. Depending on the installed attenuator, the available power ranges from a minimum of -110.00 dBm to a maximum that depends on frequency, with a resolution of 0.05 dB (see Table 1-1 for the specified maximum power available for each frequency band). If the user requests a power level that the HP 8340A cannot provide, the instrument will select the closest available power and show that value in the POWER dBm display (to ± 0.1 dB); in this situation the ENTRY DISPLAY, which shows user-selected power level, will not match the POWER dBm display which shows actual power.

The procedures for setting the power level are explained in Figures 3-7 (POWER LEVEL) and 3-17 (POWER SWEEP, PEAKING, and RF OFF).

This display can be blanked (turned off) by pressing [SHIFT] [CONT]. Although the display is blank, the power functions can be changed by the same local and remote procedures that are used with an active display. Press [SHIFT] [CONT] to regain an active display.

INDICATORS

UNLEVELED: The red UNLEVELED annunciator indicates trouble, either from operator error or machine malfunction, with one exception.

Operator error: request for too much power. If the operator requests a power output that is too high for the HP 8340A at that frequency, the UNLEVELED annunciator lights. Typically, the HP 8340A can deliver more power than listed in the specifications (Table 1-1); the UNLEVELED annunciator will light when the true maximum power level has just been exceeded. To remedy an UNLEVELED condition either [PEAK] the instrument (for CW or manual modes, as explained in Figure 3-17), or reduce the requested power.

Figure 3-3. Power dBm Display (1 of 2)

Machine malfunction: If the UNLEVELED annunciator lights, and the cause is not a request for excessive power, one or more of the power circuits are malfunctioning. If this happens, press **[INSTR PRESET]** which will restore standard instrument conditions, then re-enter the desired instrument configuration. If the UNLEVELED annunciator remains lighted, shut down the instrument and consult Section VIII (Service) of this manual.

Exception: open-loop operation. The ALC can be bypassed by pressing **[SHIFT] [METER]**, as described in Figure 3-16. Under these conditions the UNLEVELED annunciator is lighted, but acts as a reminder in this case instead of a warning.

DIAGNOSTICS

Test this display (and the three other displays) by pressing and holding **[INSTR PRESET]**, which will cause the UNLEVELED annunciator to light, then release **[INSTR PRESET]** and press **[SHIFT] [FREE RUN]** which will light every segment of the LED display ("88888"). Press **[SHIFT] [M5]** to cancel this diagnostic test.

Figure 3-3. Power μ Bm Display (2 of 2)

DESCRIPTION

This display shows (in megahertz) either the start frequency, the CW frequency, or the CF (center frequency) of the HP 8340A depending on its current operating mode.

PANEL LAYOUT

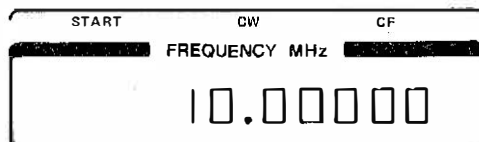

FUNCTIONS

One of three frequencies is shown in this display: Start, CW, or CF. Figure 3-7 explains the implementation of these three functions.

This display can be blanked (turned off) by pressing **[SHIFT] [CONT]**. Although the display is blanked, the Start, CW, or CF values can be changed by the same local or remote procedures that are used when the display is active. Press **[SHIFT] [CONT]** again to turn the display on.

INDICATORS

START, CW, and CF: These three amber annunciators indicate which function value is shown in the display.

DIAGNOSTICS

Press and hold **[INSTR PRESET]** to light the three annunciators, then release **[INSTR PRESET]** and press **[SHIFT] [FREE RUN]** which will light every LED segment ("888888888888"). Press **[SHIFT] [M5]** to end this diagnostic routine. (This same diagnostic procedure also tests the three other displays)

Figure 3-4. START/CW/CF Frequency Display

DESCRIPTION

This display shows, in megahertz, either the Stop frequency or the ΔF frequency span of the HP 8340A.

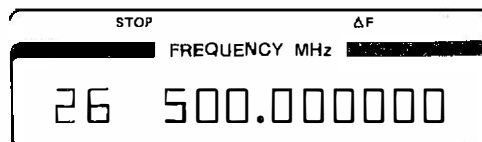
PANEL LAYOUT**FUNCTIONS**

One of two frequencies is shown in this display: Stop, or ΔF . Figure 3-7 explains the implementation of these two functions.

This display can be blanked (turned off) by pressing **[SHIFT] [CONT]**. Although the display is blanked, the Stop or ΔF values can be changed by the same local and remote procedures that are used when the display is active. Press **[SHIFT] [CONT]** again to turn the display on.

INDICATORS

STOP, ΔF : These two amber annunciators indicate which function value is shown in the display.

DIAGNOSTICS

Press and hold **[INSTR PRESET]** to light the two annunciators, then release **[INSTR PRESET]** and press **[SHIFT] [FREE RUN]** which will light every LED segment ("888888888888"). Press **[SHIFT] [M5]** to end this diagnostic routine. (This diagnostic also tests the three other displays)

Figure 3-5. STOP/ ΔF Frequency Display

DESCRIPTION

This display shows the active function and its present value, and contains the OVERMOD, REMOTE, SRQ, FAULT, OVEN, EXT REF, and UNLK indicators.

PANEL LAYOUT

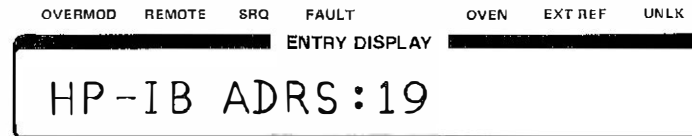

FUNCTIONS

The most recently activated function and its present value is shown in this display. In local operation, the most recently pressed function key is the active function and will remain active until superseded by the pressing of another function key. The HP 8340A will remember (for approximately one year) the activated function even when the power is disconnected, and will display that function in the ENTRY DISPLAY when the power is turned on. The HP-IB address ("HP-IB ADRS=19") is displayed momentarily at power-on, followed by a display of the active function.

In local operation, the active function can be changed by the rotary [KNOB], the [STEP] keys, or the numerical keypad. First, press one of the function keys to make that function active and display its present value in the ENTRY DISPLAY. Then, change the value of that function by using either the [KNOB], the [STEP] keys, or the numerical keys (with a terminator key).

In remote operation, the ENTRY DISPLAY will show the last function programmed.

ENTRY DISPLAY can be blanked (turned off) by pressing [ENTRY OFF]; the display will remain blanked until one of the function keys is pressed.

ENTRY DISPLAY can also be blanked by pressing [SHIFT] [CONT], which turns off all of the displays. The displays will remain blanked even when the function keys are pressed (although the annunciators will change). To regain a live display, press [SHIFT] [CONT] again.

INDICATORS

ENTRY DISPLAY contains two types of indicators: amber identification annunciators, and red warning annunciators.

REMOTE (amber) annunciator lights when the HP 8340A is being remotely controlled by a computer. When REMOTE is lighted, all front panel operations are disabled with three exceptions: The POWER switch can only be locally operated, the rotary [KNOB] can be enabled by using the EK programming code, and the [LOCAL] key will override the computer and restore local control (unless the computer sent a LOCAL LOCKOUT command to the HP 8340A, which disables the [LOCAL] key).

Figure 3-6. Entry Display (1 of 2)

FAULT (amber) annunciator lights when one of the internal circuits performs atypically. To identify the affected circuit, press [**SHIFT**] [**MANUAL**] which will cause "FAULT: CAL KICK ADC PEAK TRK" to appear in the ENTRY DISPLAY. The flashing letters identify the faulty circuit as CAL (calibration constants), KICK (YO or YTM kick pulses), ADC (analog to digital converter), PEAK (power peaking), or TRK (tracking control); at this point, Section VIII (Service) of this manual should be consulted for further instructions.

EXT REF (amber) annunciator lights when an external frequency source is used as the reference standard instead of the internal crystal oscillator. The internal/external frequency standard is selected by a rear-panel switch; see Figure 3-18 for an explanation of this switch and the associated connectors.

OVERMOD (red) annunciator lights when excessive negative voltage is applied to the front-panel AM MODULATION INPUT, which causes the HP 8340A to attempt to exceed the maximum available modulation depth. This happens at approximately -1 volt AM input. Positive excursions have no limit as long as maximum available power is not exceeded, at which point the UNLEVELED annunciator lights. AM linearity will suffer for inputs above $+1$ volt. As with the UNLEVELED annunciator, an OVERMOD indication may signify an internal malfunction.

SRQ (amber) annunciator lights when a remotely controlled HP 8340A initiates a Service Request (SRQ does not apply to local operation). Several conditions can cause a Service Request, including altered parameter values, syntax error, power failure, and unleveled power. The SRQ annunciator remains lighted until the computer sends an acknowledgment signal to the HP 8340A. Service Requests are more fully explained in the HP-IB Programming part of this Operation chapter.

OVEN (red) annunciator lights when the oven for the reference crystal oscillator is not at operating temperature. A cold oven typically requires 5-30 minutes to reach operating temperature. The STANDBY position of the POWER switch maintains power to the oven heater, thus keeping the oven warm and the crystal oscillator ready for immediate operation. Although the HP 8340A can be operated with a cold crystal oscillator, the instrument might not fully comply with specifications until the proper operating temperature is achieved.

UNLK (red) annunciator lights when the HP 8340A's output signal is no longer phase-locked to the 10 MHz reference oscillator. Press [**SHIFT**] [**EXT**], which will cause "OSC: REF M/N HET YO N2 N1" to appear in the ENTRY DISPLAY. The flashing letters indicate the oscillator that is not phase locked, which will require service as described in Section VIII (Service) of this manual.

DIAGNOSTICS

Press and hold [**INSTR PRESET**] to light the seven annunciators, then release [**INSTR PRESET**] and press [**SHIFT**] [**FREE RUN**] which will light every LED segment and show the entire ENTRY DISPLAY character set. Press [**SHIFT**] [**M5**] to end this diagnostic routine. (This diagnostic also tests the three other displays)

Figure 3-6. Entry Display (2 of 2)

DESCRIPTION

This group of keys selects frequency mode, power level, sweep time, and associated functions.

PANEL LAYOUT

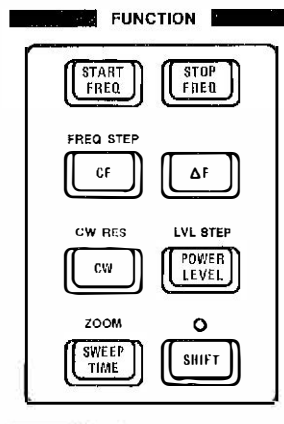

FUNCTIONS

[START FREQ] (HP-IB: FA) selects the start frequency for start/stop swept operation. Press **[START FREQ]**; then use either the rotary **[KNOB]**, the **[STEP]** keys, or the numerical keys with a terminator key to set the desired value. The start frequency must be at least 100 Hz lower than the stop frequency. If there is less than 100 Hz between start/stop, or if the start frequency is greater than the stop frequency, the HP 8340A will change the start or stop frequency to achieve the required separation. The order in which start/stop is entered is not important. If start/stop mode is interchanged with CF/ΔF mode (by pressing either of the start/stop keys and then either of the CF/ΔF keys) the sweep limits are the same. The start frequency appears in the left FREQUENCY MHz display.

[SHIFT] [START FREQ] (HP-IB: SHFA) scales the frequency displays by a multiplication factor of -30 to $+30$. This is used, for example, when a frequency doubler or tripler is connected to the RF output of the HP 8340A, and the display values are multiplied by a factor of two or three to indicate the system output frequency. Press **[SHIFT] [START FREQ]**, then enter the integer multiplication factor (-30 to $+30$) followed by any terminator key. The selected multiplication factor effects all frequency functions (start, stop, CF, ΔF, markers and marker functions, and the dB/GHz slope function), but the factor is not stored in the SAVE/RECALL registers (the current factor is used when recalling those registers). Cancel the multiplication factor by pressing **[INSTR PRESET]**, or enter a multiplication factor of 1.

[STOP FREQ] (HP-IB: FB) selects the stop frequency for start/stop swept operation. Press **[STOP FREQ]**; then use either the rotary **[KNOB]**, the **[STEP]** keys, or the numerical keys with a terminator key to set the desired value. The restrictions that apply to **[START FREQ]** also apply to **[STOP FREQ]**. The stop frequency appears in the right FREQUENCY MHz display.

Figure 3-7. Function (1 of 3)

[SHIFT] [STOP FREQ] (HP-IB: SHFB) offsets the frequency displays by a fixed amount ranging from -500 GHz to $+500$ GHz. This is used, for example, when the RF output of the HP 8340A is connected to a mixer, and for convenience the sum or difference frequency is shown in the displays. Press **[SHIFT] [STOP FREQ]**, then enter the desired offset value (-500 GHz to $+500$ GHz) followed by any terminator key. The offset affects all frequency values (start, stop, CF, CW, and markers), but the offset cancels in difference functions such as **[Δ F]**, **[Δ MKR]** and the dB/GHz **[SLOPE]** function. The offset value is not stored in the SAVE/RECALL registers, but the current offset value does change the values of a recalled register. Cancel the offset by pressing **[INSTR PRESET]**, or by entering an offset value of 0.

[CF] (HP-IB: CF) selects the center frequency for center frequency/ delta frequency swept operation. Press **[CF]**; then use either the rotary **[KNOB]**, the **[STEP]** keys, or the numerical keys with a terminator key to set the desired value. The order in which CF/ Δ F are entered is not important. Start/stop and CF/ Δ F modes can be interchanged without changing the actual sweep limits, as described in the **[START FREQ]** paragraph. The CF value appears in the left FREQUENCY MHz display.

[SHIFT] [CF] (HP-IB: SHCF) selects the incremental step size for the STEP keys (the FREQ STEP function). The step size can be as small as 1 Hz, or as large as 10 GHz. Press **[SHIFT] [CF]**, then use either the numerical keys with a terminator key, the rotary **[KNOB]**, or the **[STEP]** keys (which step in a 1-2-5 sequence at this time) to set the desired increment. After setting the step size, "FIXD" appears in the right corner of the ENTRY DISPLAY. An alternative procedure couples the FREQ STEP increment size to the Δ F frequency span: Press **[SHIFT] [CF] [AUTO]** (causing "AUTO" to appear in the ENTRY DISPLAY) and the increment size will become 1/10 of the frequency span. AUTO is the default condition after an **[INSTR PRESET]**. The step size established by the FREQ STEP function is the same for start/stop frequencies, CF/ Δ F frequencies, the markers, and manual sweeps. The **[STEP]** keys are explained in Figure 3-8.

[Δ F] (HP-IB: DF) selects the delta frequency (frequency span) for center frequency/ delta frequency swept operation. Press **[Δ F]**; then use either the **[STEP]** keys, the numerical keys with a terminator key, or the rotary **[KNOB]** to set the desired value. The HP 8340A will sweep from $1/2 \Delta F$ below to $1/2 \Delta F$ above the center frequency. The restrictions that apply to **[CF]** also apply to **[Δ F]**. The right FREQUENCY MHz displays shows the **[Δ F]** value.

[SHIFT] [Δ F] has no effect on the HP 8340A.

[CW] (HP-IB: CW) selects a synthesized CW frequency. Press **[CW]**; then use either the rotary **[KNOB]**, the **[STEP]** keys, or the numerical keys with a terminator key to set the desired value. The right side of the ENTRY DISPLAY shows either "AUTO" if the **[STEP]** keys and **[KNOB]** are coupled to the Δ F frequency span, or "FIXD" if they are not coupled (see the **[SHIFT] [CF]** and **[SHIFT] [CW]** paragraphs for an explanation). The left FREQUENCY MHz display shows the CW value.

[SHIFT] [CW] (HP-IB: SHCW) sets the sensitivity of the rotary **[KNOB]** (the CW RES function) for adjusting the CW value. Press **[CW]** to enter CW mode, and set the desired CW value as described in the preceding paragraph. Then, press **[SHIFT] [CW]** and observe the flashing cursor in the ENTRY DISPLAY, which identifies the digit presently affected by the rotary **[KNOB]**. Reposition the cursor by pressing either the left-arrow or right-arrow **[STEP]** key (the arrows are printed in blue above the **[STEP]** keys). When the cursor is

Figure 3-7. Function (2 of 3)

positioned over the desired digit, press **[CW]** to return to CW mode. After changing the CW RES, "FIXD" appears in the right corner of the ENTRY DISPLAY. However, the CW RES can be coupled to the ΔF frequency span ("AUTO" in the ENTRY DISPLAY) by pressing **[SHIFT] [CW] [AUTO]**, which causes the CW RES to be 1/1000 of the frequency span, reduced to the next lowest integer power of ten (for example, a frequency span of 16 GHz corresponds to a CW RES of: $16 \text{ GHz}/1000 = 16 \text{ MHz}$; 16 MHz reduced to the next lowest integer power of ten equals 10 MHz, which is the CW RES). For frequency spans less than 1000 Hz, the AUTO CW RES is 10 Hz. AUTO is the default condition for CW RES after an **[INSTR PRESET]**.

[POWER LEVEL] (HP-IB: PL) controls the output power level of the HP 8340A, when it is internally leveled. Press **[POWER LEVEL]**; then use either the rotary **[KNOB]**, the **[STEP]** keys, or the numerical keys with the **[dB(m)]** terminator key to set the desired value (resolution 0.05 dB). When externally leveled, **[POWER LEVEL]** selects the external detector feedback voltage to which the HP 8340A will attempt to level, with a range of +6 dBV (2.00 V) to -66 dBV (500 μ V) and a resolution of 0.1 dB. The EXT INPUT (BNC connector) accepts either positive or negative inputs. When in the **[SHIFT] [METER]** (open-loop) mode the **[POWER LEVEL]** entry controls the linear modulator, as explained in Figure 3-16. In any of these three modes, the POWER dBm display shows the output power to the nearest 0.1 dB (see Figure 3-3 for information on this display, and its UNLEVELED indicator). The output power can range from -110 dBm to a maximum value that depends on frequency (see Table 1-1 for power specifications). Figure 3-17 explains **[PEAK]**, **[PWR SWP]**, and **[SLOPE]** power functions.

[SHIFT] [POWER LEVEL] (HP-IB: SHPL) selects the incremental step size for the **[STEP]** keys when they are used for the power level functions (**[POWER LEVEL]**, **[PWR SWP]**, or **[SLOPE]**). This is the LVL STEP function. Press **[SHIFT] [POWER LEVEL]**; then use either the rotary **[KNOB]**, the **[STEP]** keys (which step in a 1-2-5 sequence in this mode), or the numerical keys with the **[dB(m)]** terminator key to set the desired step size. The step size can range from 0.05 dB to 50.00 dB. Consult Figures 3-3 and 3-17 for further information on power functions.

[SWEEP TIME] (HP-IB: ST) selects the sweep times for frequency sweeps or power sweeps (power sweep is explained in Figure 3-17). Press **[SWEEP TIME]**; then use either the **[STEP]** keys (which increment in a 1-2-5 sequence for sweep time), the rotary **[KNOB]**, or the numeric keys with the **[sec]** or **[msec]** terminator key to set the desired value. Sweep time has an allowable range of 10 msec to 200 seconds, but the fastest sweep time is constrained by the frequency span: The sweep rate cannot exceed 600 MHz/msec (for example, the full 26.49 GHz frequency span of the HP 8340A can be swept no faster than $26490/600 = 44.15 \text{ msec}$). The fastest possible sweep can be determined automatically: Press **[SWEEP TIME] [AUTO]** to obtain the fastest possible calibrated sweep time for any sweep span. The right-hand corner of the ENTRY DISPLAY shows "AUTO" when the sweep time is coupled to the frequency span, or "FIXD" when sweep time is independent. AUTO is the default condition after an **[INSTR PRESET]**. Also, see **TL** in the HP-IB section.

[SHIFT] [SWEEP TIME] (HP-IB: SHST) places the HP 8340A into CF/ ΔF sweep mode, with ΔF controlled only by the **[STEP]** keys and CF controlled by either the rotary **[KNOB]** or the numerical keys (with a terminator key). This is the ZOOM function, which allows the operator to quickly zoom-in on a frequency band of interest even from very wide sweeps.

[SHIFT] (HP-IB: SH) activates functions that are printed in blue on the front panel, as well as special functions. All **[SHIFT]** functions are described in this Operation chapter, and are summarized on the two information cards located below the HP 8340A.

Figure 3-7. Function (3 of 3)

DESCRIPTION

The rotary **[KNOB]** and **[STEP]** keys affect the function that is presently being shown in the ENTRY DISPLAY. **[ENTRY OFF]** blanks the ENTRY DISPLAY.

PANEL LAYOUT

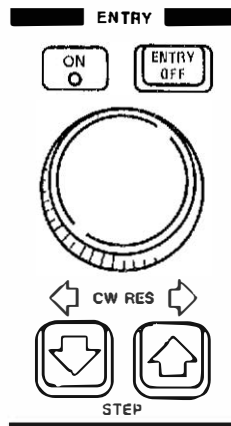

FUNCTIONS

[ENTRY OFF] (HP-IB: EF) blanks (turns off) the ENTRY DISPLAY, and disables the **[STEP]** keys and the rotary **[KNOB]**. When any function key is pressed ENTRY DISPLAY is reactivated, the **ON** indicator next to **[ENTRY OFF]** lights, and the **[KNOB]** and **[STEP]** keys are enabled. To blank the ENTRY DISPLAY without disabling the **[KNOB]** or **[STEP]** keys, press **[SHIFT] [CONT]** (as described in Figure 3-6).

[SHIFT] [ENTRY OFF] has no effect on the HP 8340A.

ROTARY KNOB (HP-IB: EK) allows analog-type adjustment of the function shown in the ENTRY DISPLAY. Press any function key to activate that function, then turn the rotary **[KNOB]** to obtain the desired value. **[SHIFT] [CW]** in Figure 3-7 explains the procedure for adjusting the sensitivity of the rotary Knob. Although the **[KNOB]** has the feel of an analog control, it is actually a digital control that generates 120 pulses per revolution (the **[KNOB]** is frequently referred to as an RPG - rotary pulse generator - in service literature).

[SHIFT] ROTARY KNOB: **[SHIFT]** does not effect the rotary **[KNOB]**.

STEP KEYS (HP-IB: UP for up-increment, DN for down-increment) change the value of any active function by an incremental step. Press any function key to activate that function, then press either the up-arrow or down-arrow **[STEP]** key to incrementally change the value of that function. Press and hold a **[STEP]** key for a repeat action. The active function is always shown in the ENTRY DISPLAY. **[SHIFT] [CF]** and **[SHIFT] [POWER LEVEL]** in Figure 3-7 explain the procedures for changing the size of the increment step (although for sweep times the increment is a fixed 1-2-5 sequence). After an **[INSTR PRESET]** the step size increments default to 1/10 of the current sweep width (changing as the width changes) for the **FREQ STEP**, and to 10.00 dB for the **LVL STEP**.

Figure 3-8. KNOB/STEP Entry (1 of 2)

[SHIFT] STEP KEYS: **[SHIFT]** does not effect the **[STEP]** keys; however, the **[STEP]** keys are used for the shifted CW RES function. CW RES is accomplished by pressing **[SHIFT][CW]**, then using the **[STEP]** key to move the cursor left or right in the ENTRY DISPLAY. **[SHIFT][CW]** in Figure 3-7 explains the CW RES function.

INDICATORS

ON is an LED that is lighted when the **[STEP]** keys and rotary **[KNOB]** are enabled, not lighted when those controls are disabled. The preceding **[ENTRY OFF]** paragraph contains additional information about this indicator.

Figure 3-8. *KNOB/STEP Entry (2 of 2)*

DESCRIPTION

This key group selects the five marker functions (MARKER SWEEP, MARKER DELTA, and MARKER TO CENTER FREQUENCY), and several diagnostic functions that are used during servicing.

PANEL LAYOUT

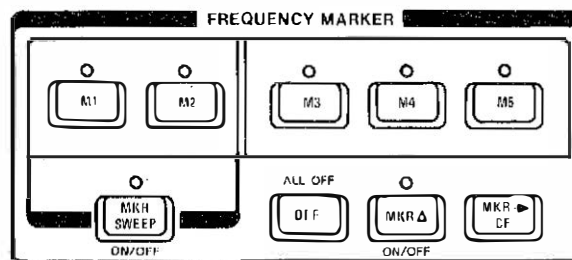

FUNCTIONS

[M1] . . . [M5] (HP-IB: M1 . . . M5) keys select markers 1-5. Press one **[M1] . . . [M5]** key, and the present value of that marker will appear in the ENTRY DISPLAY. Use either the rotary **[KNOB]**, the **[STEP]** keys, or the numerical keys with a terminator key to set the desired marker frequency. Repeat this process for the other markers as needed. If the initial marker frequency is outside of the current sweep range, a slight turn of the **[KNOB]** will bring the frequency of that marker to the center frequency of the sweep. Markers are normally displayed as z-axis intensity dots but can be changed to amplitude “dips” (an abrupt discontinuity in the sweep trace) by pressing **[AMTD MKR]**, as explained in Figure 3-17. The markers are functional whenever their individual LEDs are lighted; however, only one marker can be “active” at a time (the “active” marker is shown in the ENTRY DISPLAY, and can be changed via **[KNOB]**, **[STEP]** keys, or numerical keys with a terminator key). Press any marker key to make that marker active. After **[INSTR PRESET]** all markers are initialized to 13.255 GHz; otherwise, the last-used marker values will be remembered by the HP 8340A (for up to one year), even with disconnected ac power.

[SHIFT][M1] (HP-IB: SHM1) is a service diagnostic that shows (from left to right) the M divisor, N divisor, M/N frequency, and 20/30 loop frequency. Consult Section VIII (Service) for additional information.

[SHIFT][M2] (HP-IB: SHM2) is a service diagnostic that shows (from left to right), the band number and the YIG oscillator (YO) frequency. Consult Section VIII (Service) for further information.

[SHIFT][M3] (HP-IB: SHM3) is a service diagnostic that shows, from left to right, the PLL #2 VCO frequency and the PLL #3 upconverter frequency. Consult Section VIII (Service) for additional information.

Figure 3-9. *Frequency Marker (1 of 3)*

INSERT IN FRONT OF THE OPERATING INFORMATION MANUAL IN SECTION III, OPERATION

SUPPLEMENTAL CHANGES TO SECTION III, OPERATION

The Operating Information manual in section III is a bound section of the manual. This allows the operator to remove the document and refer to it more easily. However, the binding makes it impossible to provide replacement pages for this section. This supplement should be kept with the Operating Information booklet for reference.

The following information documents corrections and revisions to the Operating Information manual. Information accompanied by the term "ALL SERIALS" applies to any HP 8340A, regardless of serial number. Information accompanied by a serial number prefix (e.g. 2447A, etc.) only applies to instruments of that serial number prefix or higher.

Page 3-18, [SHIFT] [M4] Description (ALL SERIALS):

The following [SHIFT] [M4] description supersedes the description currently in the manual: [SHIFT] [M4] (HP-IB: SHM4) activates 32 service diagnostic routines which test the DACs and control circuitry on the A27 level control, A28 SYTM driver, A57 marker bandcross, and A58 sweep generator. This diagnostic also allows the results of the self-test, run at power on and after an [INSTR PRESET], to be displayed in the front panel **ENTRY DISPLAY**. For more information, refer to the A60 Processor assembly troubleshooting in the Controller Section.

External Controller Programming:

An HP Series 200 controller may be programmed to interrogate the HP 8340A and print out the results of the 32 [SHIFT] [M4] diagnostic tests. The instrument sends a string of 32 characters to the external controller. These characters may be either 1 or 0 indicating a passed or failed test respectively. The external controller will print the name of each test and show whether it passed or failed. Test results will be printed out on the device specified by the operator. In Basic:

```

100 DIM Test_no$(32)[20]
110 OUTPUT 719;"SHM4"
120 FOR I=1 TO 32
130 READ Test_no$(I)
140 DATA "PROCESSOR TST", "ROM 1 CKSUM", "ROM 2 CKSUM", "ROM 3 CKSUM",
"ROM 4 CKSUM", "RAM 1 RD/WR", "RAM 2 RD/WR", "EEROM 1 RD/WR", "EEROM
2 RD/WR"
150 DATA "MRK RAM RD/WR", "PIT(LED REG)", "PIT RESPONDS", "IO ADDR BUS",
"IO DATA BUS", "A-D CONVERTER", "LEVEL REF DAC", "MAN SWP DAC",
"MARKER RAMP"
160 DATA "RESET DAC", "LEVEL SWP DAC", "BND CROSS DAC", "SWP WIDTH DAC",
"SWP RANGE ATN", "V/GHz CIRCUIT", "V/GHz BND ATN", "BRK PNT 1 DAC",
"BRK PNT 2 DAC"
170 DATA "ATN SLOPE DAC", "YO PRETUN DAC", "NOT USED", "A27 INSTALLED"
180 NEXT I
190 DIM Dt$(32)
200 OUTPUT 719; "OD"
210 ENTER 719; Dt$

```

```
220 FOR I=1 TO 32
230 IF Dt$(I,I) = "1" THEN
240 IMAGE 13A, 10X, "PASS"
250 PRINT USING 240: Test_no$(I)
260 ELSE
270 IMAGE 13A, 10X, "FAIL"
280 PRINT USING 270: Test_no$(I)
290 END IF
300 NEXT I
310 END
```

Page 3-34, [SHIFT] [RF] Description (ALL SERIALS):

The following **[SHIFT] [RF]** description supersedes the description currently in the manual:

[SHIFT] [RF] (HP-IB: SHRF) disables the ALC (automatic leveling control) to allow direct control of the linear modulator circuit. This is useful when very narrow pulses are being generated in pulse modulation mode. When **[SHIFT] [RF]** is engaged, there is no limit on the minimum pulse repetition frequency.

The following message will be displayed in the **ENTRY DISPLAY**: "**POWER SEARCH: X.XX dB**" (where X.XX is the last-entered power value).

To set the power level, place the HP 8340A in CW mode, or in pulse modulation mode with pulses wider than 2 usec, and use the **[STEP]** keys, the rotary **[KNOB]** or the data entry keypad with the **[dBm]** terminator key to enter the power level desired. The **POWER dBm** display shows the actual power when the instrument is in CW or pulse modulation mode. The accuracy of the **POWER dBm** display is typically the same as when the instrument is leveled. Table 1-1 contains this information under **PULSE MODULATION** specifications, **ACCURACY OF INTERNALLY LEVELED RF PULSE Vp (relative to CW mode level)**. The actual power changes very little as the pulse width is narrowed, even though the **POWER dBm** reading drops. Therefore, at very narrow pulse widths, ignore this reading.

[SHIFT] [RF] can also be used as a diagnostic function of the ALC circuits (refer to the ALC loop description/troubleshooting in the beginning of the RF Section for more information).

[SHIFT] [M4] (HP-IB: SHM4) activates 32 service diagnostic routines which test the DACs and control circuitry on the A27 level control, A28 SYTM driver, A57 marker bandcross, and A58 sweep generator. This diagnostic also allows the results of the self-test, run at power on and after on **[INSTR PRESET]**, to be displayed in the front panel **ENTRY DISPLAY**. For more information, refer to the A60 Processor assembly troubleshooting in the Controller Section.

External Controller Programming:

An HP Series 200 controller may be programmed to interrogate the HP 8340A and print out the results of the 32 **[SHIFT] [M4]** diagnostic tests. The instrument sends a string of 32 characters to the external controller. These characters may be either 1 or 0 indicating a passed or failed test respectively. The external controller will print the name of each test and show whether it passed or failed. Test results will be printed out on the device specified by the operator. In Basic:

```

100 DIM TEST_no$(32)[20]
110 OUTPUT 719;"SHM4"
120 FOR I=1 TO 32
130 READ Test_no$(I)
140 DATA "PROCESSOR TST", "ROM 1 CKSUM", "ROM 2 CKSUM", "ROM 3 CKSUM",
"ROM 4 CKSUM", "RAM 1 RD/WR", "RAM 2 RD/WR", "EEROM 1 RD/WR", "EEROM
2 RD/WR"
150 DATA "MRK RAM RD/WR", "PIT(LED REG)", "PIT RESPONDS", "IO ADDR BUS",
"IO DATA BUS", "A-D CONVERTER", "LEVEL REF DAC", "MAN SWP DAC",
"MARKER RAMP"
160 DATA "RESET DAC", "LEVEL SWP DAC", "BND CROSS DAC", "SWP WIDTH DAC",
"SWP RANGE ATN", "V/GHz CIRCUIT", "V/GHz BND ATN", "BRK PNT 1 DAC",
"BRK PNT 2 DAC"
170 DATA "ATN SLOPE DAC", "YO PRETUN DAC", "NOT USED", "A27 INSTALLED"
180 NEXT I
190 DIM Dt$(32)
200 OUTPUT 719; "OD"
210 ENTER 719; Dt$
220 FOR I=1 TO 32
230 IF Dt$(I,I) = "1" THEN
240 IMAGE 13A, 10X, "PASS"
250 PRINT USING 240: Test_no$(I)
260 ELSE
270 IMAGE 13A, 10X, "FAIL"
280 PRINT USING 270; Test_no$(I)
290 END IF
300 NEXT I
310 END

```

[SHIFT] [M5] (HP-IB: SHM5) turns off any diagnostic routine and restores the displays to their previous condition.

[MKR SWEEP] (HP-IB: MP1 activates the function, MP0 turns off the function) causes the HP 8340A to start sweeping at the frequency marker **[M1]**, and stop sweeping at the frequency of marker **[M2]** (**[M2]** must have a higher frequency than **[M1]**). If **[MKR SWEEP]** is activated when **[M2]** is at a lower frequency than **[M1]**, the values of **[M1]/[M2]** will be permanently interchanged. Press **[MKR SWEEP]** again to exit from Marker Sweep and return to the previous sweep limits. The LED above the key indicates whether the function is on (lighted), or off (not lighted).

Figure 3-9. Frequency Marker (2 of 3)

[SHIFT] [MKR SWEEP] (HP-IB: SHMP) causes the sweep limits to permanently change to the frequencies of **[M1]** and **[M2]**. Repeated pressing of **[MKR SWEEP]** alone causes the HP 8340A to toggle between **[M1]/[M2]** sweeps and the previous sweep frequencies; **[SHIFT] [MKR SWEEP]** eradicates the previous sweep values, leaving only the **[M1]/[M2]** frequencies.

[OFF] (HP-IB: M0) turns off (deactivates) any single marker. Press any marker key **[M1] . . . [M5]**, then press **[OFF]** to deactivate that marker. If **[OFF]** is pressed without first pressing a marker key, the most recently active marker will be turned off. The frequency value of the deactivated marker is retained in memory, and will be recalled when that marker key is pressed once again. A deactivated marker will not affect the **[MKR SWEEP]**, **[MKR Δ]**, or **[MKR → CF]** functions.

[SHIFT] [OFF] (HP-IB: SHM0) turns off (deactivates) all markers, **[M1]** through **[M5]**. However, the frequency values of all markers are retained in memory, and will be recalled when the marker keys are pressed once again. Deactivating the markers will not affect the **[MKR SWEEP]**, **[MKR Δ]**, or **[MKR → CF]** functions.

[MKR Δ] (HP-IB: MD1 turns on the function, MD0 turns off the function) causes the frequency difference between any two markers to appear in the ENTRY DISPLAY. Press any two marker keys **[M1] . . . [M5]**, then press **[MKR Δ]** and the ENTRY DISPLAY will show the frequency difference. Press any other marker keys **[M1] . . . [M5]**, and the ENTRY DISPLAY will change to show the frequency difference between the two most recently pressed markers. On a CRT display, the trace between the two selected markers is intensified (intensity markers only, not **[AMTD MKR]**). The LED above **[MKR Δ]** shows when the function is on (lighted), or off (not lighted).

[SHIFT] [MKR Δ]: SHIFT has no effect on **[MKR Δ]**.

[MKR → CF] (HP-IB: MC) sets the center frequency of the sweep to the frequency of the active marker. Press any marker key **[M1] . . . [M5]**, then press **[MKR → CF]** to change the center frequency of the sweep to that of the marker. The frequency span, **[ΔF]**, will not change unless the new sweep limits fall outside the frequency range of the HP 8340A; in that case, the HP 8340A will automatically scale down the **ΔF** to be within the frequency range.

[SHIFT] [MKR → CF] has no effect on the HP 8340A.

Figure 3-9. Frequency Marker (3 of 3)

DESCRIPTION

This is the numerical keypad, with the terminator keys, that provides data entry to the HP 8340A.

PANEL LAYOUT

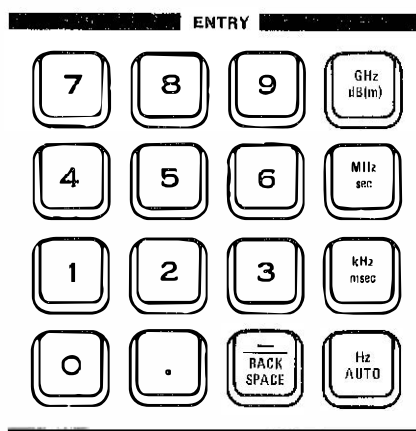

FUNCTIONS

[.] [0]...[9] (HP-IB: decimal numbers 0 through 9, - (minus) sign, and decimal point) are the numerical data entry keys. Press any function key, enter the desired numerical value, then press the appropriate terminator key (GHz, sec, dB(m), etc.). Table 1-1 (Specifications) lists the numerical limits for each function.

[SHIFT] (data entry key) has no effect on the HP 8340A.

[- / BACK SPACE] is a minus sign (-) entry when this key is pressed at the beginning of a data entry sequence, a back space at all other times.

[SHIFT] [- / BACK SPACE] has no effect on the HP 8340A.

[GHz / dB(m)] [MHz / sec] [kHz / msec] [Hz / AUTO] are the terminator keys that must be pressed after a numerical value has been entered. The HP 8340A interprets the terminator key to match the selected function. For example, GHz is selected when a frequency function is active, dB(m) is selected when a power function is active. An explanation of each key follows.

[GHz / dB(m)] (HP-IB: GZ, or DB) selects either gigahertz for a frequency function, decibels or dBm for a power function.

[MHz / sec] (HP-IB: MZ, or SC) selects either megahertz for a frequency function, or seconds for a sweep time function.

[kHz / msec] (HP-IB: KZ, or MS) selects either kilohertz for a frequency function, or milliseconds for a sweep time function.

Figure 3-10. Entry (1 of 2)

[HZ / AUTO] (HP-IB: HZ, or AU) selects hertz for a frequency function; AUTO affects **[SWEEP TIME]**, **FREQ STEP**, and **CW RES**: Press **[SWEEP TIME]** then **[AUTO]** to obtain the shortest possible sweep time for that frequency span; press **[SHIFT] [CF]** then **[AUTO]** to couple the **FREQ STEP** increment size to the ΔF frequency span; press **[SHIFT] [CW]** then **[AUTO]** to couple the **CW RES** to the ΔF frequency span (all of these shifted functions are explained in Figure 3-7). When one of the AUTO-coupled functions is active, "AUTO" or its complement "FIXD" (which indicates that AUTO is not active) appears in the **ENTRY DISPLAY**.

[SHIFT] (terminator key) allows direct electrical access to the internal circuits, registers, and buffers of the HP 8340A. These tremendously powerful functions are comprehensively explained in Section VIII (Service); however, a brief explanation follows.

[SHIFT] [GHz / dB(m)] (HP-IB: SHGZ) allows the I/O channel to be specified. The I/O channel, along with the I/O subchannel (explained in the following paragraph) defines the address for a circuit board or memory register that is accessible via the internal I/O bus. The channel values range from 0 to 15. Channel and subchannel addresses are listed in Section VIII. Press **[SHIFT] [GHz / dB(m)]**, then enter a numerical value between 0-15, followed by any terminator key.

[SHIFT] [MHz / sec] (HP-IB: SHMZ) allows the I/O subchannel to be specified. Press **[SHIFT] [MHz / sec]**, then enter a numerical value followed by any terminator key.

[SHIFT] [kHz / msec] (HP-IB: SHKZ) allows a numerical value to be written to the address defined by the channel and subchannel. The appropriate numerical value is explained in the relevant parts of Section VIII. Press **[SHIFT] [kHz / msec]**, enter a numerical value, followed by any terminator key.

[SHIFT] [Hz / AUTO] (HP-IB: SHHZ) allows a numerical value to be read from the address defined by the channel and subchannel. Press **[SHIFT] [Hz / AUTO]**, and the numerical data will appear in the **ENTRY DISPLAY**. The relevant parts of Section VIII describe the interpretation of this data.

Figure 3-10. Entry (2 of 2)

DESCRIPTION

Continuous, single, or manual sweeps and internal, external or power line triggering are controlled by these keys. Additionally, display blanking, penlift, and three diagnostic functions are enabled by adding the SHIFT prefix to these keys.

PANEL LAYOUT

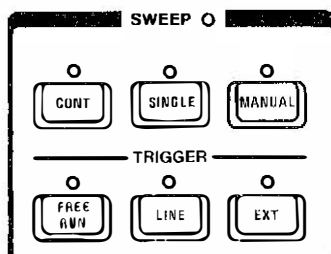

FUNCTIONS

[CONT] (HP-IB: S1) allows continuous sweep-retrace-sweep-retrace cycling of the HP 8340A. The sweep is initiated by one of the TRIGGER functions, as explained later in this Figure, while the sweep speed is controlled by the **[SWEEP TIME]** function as explained in Figure 3-7.

[SHIFT] [CONT] (HP-IB: SHS11 disables displays, SHS10 re-enables displays) blanks (turns off) all displays on the HP 8340A. Although the displays are blanked, the functions that are normally shown in the displays can still be changed in the usual manner, and the changed values will be shown when the displays are reactivated. The displays are reactivated in one of two ways: Press **[SHIFT] [CONT]** again to restore the displays, or press **[SHIFT] [M5]** which always restores the displays and cancels any diagnostic routines that are in effect.

[SINGLE] (HP-IB: S2) allows single sweeps of the HP 8340A. Press **[SINGLE]** to start the sweep, which will sweep at a rate determined by the **[SWEEP TIME]** function (explained in Figure 3-7). If **[SINGLE]** is pressed in the middle of a single sweep, the sweep will abruptly stop and the HP 8340A will retrace back to the starting point.

[SHIFT] [SINGLE] has no effect on the HP 8340A.

[MANUAL] (HP-IB: S3) allows manual sweeps. Press **[MANUAL]**, then use the rotary **[KNOB]** to manually sweep between the start/stop limits. In manual mode the HP 8340A will not automatically retrace at the sweep end point (the operator must retrace), and the green LED by the SWEEP label will not light. The resolution of the **[KNOB]** is 0.1% of the sweep span in either start/stop or CF/ Δ F mode. Frequencies in manual sweep are synthesized, just as they are in CW mode.

Figure 3-11. Sweep and Trigger (1 of 3)

There are two significant differences between **[MANUAL]** sweep and the sweep that can be obtained by having the **[KNOB]** control an active CW function:

1. The sweep output voltage ramp (see Figures 3-13 or 3-18, SWEEP OUTPUT) is 0-10 volts in both modes, but in CW mode 0 volts always corresponds to 10 MHz and 10 volts always corresponds to 26.5 GHz, while in manual sweep mode 0 volts corresponds to the start frequency and 10 volts corresponds to the stop frequency. In both cases the sweep voltage at intermediate frequencies is a linear interpolation of the frequency span (i.e., a frequency half-way between the start/stop limits has a corresponding sweep voltage of 5 volts).
2. The bandcrossing points in CW mode always occur at precisely 2.3, 7.0, 13.5, and 20.0 GHz. In manual sweep mode the bandcrossing points have 200 MHz of flexibility, which is automatically used by the HP 8340A for optimum performance (for example, a 2.35 to 7.05 sweep could be accomplished without any band changes in manual sweep mode).

[SHIFT] [MANUAL] (HP-IB: SHS3) activates the FAULT diagnostic routine. When the amber FAULT annunciator appears in the ENTRY DISPLAY, press **[SHIFT] [MANUAL]** to initiate the FAULT diagnostic which will cause "FAULT: CAL KICK ADC PEAK TRK" to appear in the ENTRY DISPLAY. The flashing cursor indicates which circuit (**CAL**ibration constants, **KICK** pulses, **A**nalog to **D**igital **C**onverter, power **PEAK**ing, or **TRAcK**ing) is causing the problem. Once the faulty circuit has been identified, consult Section VIII (Service) for instructions on how to remedy the problem.

[FREE RUN] (HP-IB: T1) allows internal triggering of the any sweep function, and is the fastest possible way to accomplish the sweep-retrace cycle.

[SHIFT] [FREE RUN] (HP-IB: SHT1) activates the display self-test diagnostic function. Press **[SHIFT] [FREE RUN]**, which will cause every segment of every LED in the displays to light, followed by a marching pattern of every character in the display lexicon. Press **[SHIFT] [M5]** to cancel this diagnostic routine and to restore the displays to their previous condition. If this marching display ever appears spontaneously, especially at power-on, the main processor circuit has failed and Section VIII (Service) should be consulted for further instructions.

Figure 3-11. Sweep and Trigger (2 of 3)

[LINE] (HP-IB: T2) triggers the sweep functions in synchronization with the ac power line frequency, which is typically 50 or 60 Hz.

[SHIFT] [LINE] (HP-IB: SHT21 enables penlift, SHT20 disables penlift) generates a penlift signal at each band crossing. When an HP 8340A sweep crosses frequency bands, the RF is momentarily turned off at each band crossing which can cause a negative spike on X-Y recorders. To prevent the negative spike, **[SHIFT] [LINE]** activates a rear-panel PENLIFT OUTPUT connector that causes the X-Y recorder's pen to lift at each band crossing. The PENLIFT function works only when the sweep time is > 5 seconds. See Figure 3-18 for information on the rear-panel connector, and the X-Y Recorder Operating Guide (at the end of Section III) for specific information on X-Y recorder interconnections.

[EXT] (HP-IB: T3) externally triggers the sweep function. Figure 3-18 explains the rear-panel EXT TRIGGER INPUT connector and the trigger signal requirements.

[SHIFT] [EXT] (HP-IB: SHT3) activates the oscillator diagnostic function. When the red UNLK annunciator appears in the ENTRY DISPLAY, press **[SHIFT] [EXT]**, which will cause "OSC: REF M/N HET YO N2 N1" to appear in the ENTRY DISPLAY. The flashing cursor indicates which oscillator circuit is not phase locked, with the remedy found in the appropriate part of Section VIII (Service). Press **[SHIFT] [M5]** to cancel this diagnostic function and to return the displays to their previous condition.

INDICATORS

SWEEP green LED lights when the HP8340A is performing an analog sweep. The LED is off during all of the following: retrace, band crossings (band crossings occur at 2.3 GHz, 7.0 GHz, 13.5 GHz, and 20.0 GHz), during the phase locking that occurs at the start frequency of each new sweep and each new band, and during manual sweeps (since manual sweeps are synthesized).

Figure 3-11. Sweep and Trigger (3 of 3)

DESCRIPTION

Instrument check and preset, HP-IB address assignment, storage and recall of operating configurations, alternating operation, and restoration of local control are the functions of this key group.

PANEL LAYOUT

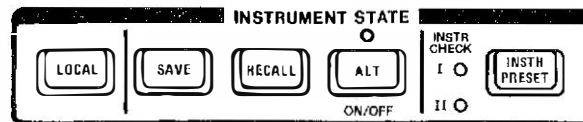

FUNCTIONS

[LOCAL] (HP-IB: LOCAL command). The front panel keys (except **[LOCAL]** and the POWER switch) are inoperative when the HP 8340A is being remotely controlled by a computer. Press **[LOCAL]** to cancel computer control and to reactivate the front panel keys. **[LOCAL]** does not work if the computer executed a LOCAL LOCKOUT command, as explained in the HP-IB section of this chapter.

[SHIFT] [LOCAL] (no HP-IB code) causes the HP-IB address to appear in the ENTRY DISPLAY. The factory-set address is 19; however, any unique address between 00-30 can be assigned to the HP 8340A by pressing **[SHIFT] [LOCAL]**, entering the address numbers, and pressing any terminator key (GHz, MHz, kHz, Hz). This new address remains in effect until again changed by the operator. The calibration constants (described in Section VIII) can be configured to disable the **[SHIFT] bLOCAL** function, thus locking the HP 8340A to the address specified in the calibration constants.

[SAVE] (HP-IB: SV_n, n=1-9) allows up to 9 different front panel settings to be stored in memory registers 1 through 9. Instrument settings can then be recalled via the **[RECALL] n** (n = 0 through 9, where 0 is the last-used front panel setting) function, or a memory setting can be alternated with the current front panel setting with the **[ALT] n** (n = 1 - 9) function. Set the front panel controls to any desired configuration, then press **[SAVE]** which will cause "SAVE REGISTER: ?" to appear in the ENTRY DISPLAY. Press any digit 1-9 to select the storage register, and the setting will be saved in that register. The information stored in the memory registers is retained in memory indefinitely when ac line power is constantly available, or for approximately one year without line power.

[SHIFT] [SAVE] (HP-IB: SHSV) is a save-lock that prevents any new front panel settings from being saved. **[SHIFT] [RECALL]** removes the save lock.

[RECALL] (HP-IB: RC_n, n=0-9) retrieves a front panel setting that was previously SAVED in storage registers 1-9 (**[RECALL] [0]** retrieves the last-entered front panel setting). Press **[RECALL]**, which will cause "RECALL REGISTER: ?" to appear in the ENTRY DISPLAY. Then press any digit 0-9, or use the **[STEP]** keys, to select the desired memory register. (The rear panel "8410 CONNECTOR" has a pin that duplicates the step-recall function, as explained in Figure 3-21 and the HP 8340A/HP 8410 Operating Guide)

[SHIFT] [RECALL] (HP-IB: SHRC) cancels the save-lock function, which is described in the previous **[SHIFT] [SAVE]** paragraph.

Figure 3-12. Instrument State (1 of 2)

[ALT] (HP-IB: AL1n, n=1-9 turns on the function, AL0 turns off the function) causes the instrument state to alternate on successive sweeps between the current front panel setting and the setting stored in memory location 1-9. Press **[ALTb]**, which will cause "ALT WITH REGISTER: ?" (? is the last used memory register) to appear in the ENTRY DISPLAY, then press a digit 1-9 to select the desired memory register. Although the HP 8340A is in the alternate mode, the panel displays will only show the current front panel state. The power level of the two alternated functions must have the same attenuator setting, or the attenuator must be decoupled from the ALC (automatic leveling control circuit) which will allow up to 40 dB of power level difference. This restriction is necessary to prevent rapid cycling, and subsequent wear, on the mechanical attenuator. See **[PWR SWP]** in Figure 3-17 for an explanation of the attenuator and ALC relationship. Press **[ALT]** again to cancel the alternate function.

[SHIFT] [ALT] has no effect on the HP 8340A.

[INSTR PRESET] (HP-IB: IP) causes an internal self-test of the HP 8340A, and initializes the instrument to a standard starting configuration:

1. Start sweep at 10 MHz, stop sweep at 26.5 GHz.
2. Power level set to 0.0 dBm; however, this level can be reset by changing the calibration constants (as described in Section VIII).
3. Sweep time to AUTO (44.15 msec).
4. CONT sweep, FREE RUN trigger.
5. All markers set to 13.255 GHz (center frequency of the sweep).
6. The checksum of the calibration data is calculated, and if an error is detected then the calibration data in protected memory is used. If the checksum of the protected data is not correct then default values are used, and the FAULT annunciator lights in the ENTRY DISPLAY to indicate a calibration constant error (press **[SHIFT] [MANUAL]** when the FAULT annunciator lights, as described in Figure 3-11).
7. All function values stored in memory registers 1-9 are reset to default values.
8. A self test is performed, and check LEDs are lighted.

Press **[INSTR PRESET]** at any time to test the instrument and restore the standard starting condition. If either of the two red LEDs that are adjacent to **[INSTR PRESET]** (labeled "INSTR CHECK I / II") remain lighted after a preset, the HP 8340A failed the self-test; refer to Section VIII (Service) for further instructions.

[SHIFT] [INSTR PRESET]: **[SHIFT]** has no effect on **[INSTR PRESET]**.

INDICATORS

INSTR CHECK I / II red LEDs light if the HP 8340A fails the internal self-test that occurs when **[INSTR PRESET]** is pressed. If this happens, refer to Section VIII (Service) for further instructions.

Figure 3-12. Instrument State (2 of 2)

DESCRIPTION

The **POWER** power switch and the **SWEEP OUTPUT** front-panel BNC connector are described in this Figure.

PANEL LAYOUT

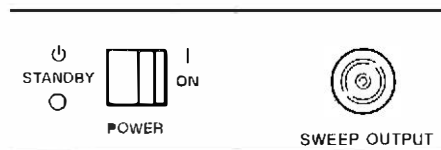

FUNCTIONS

POWER SWITCH selects either ON, or STANDBY. Once the ac power line has been plugged in, power is always being applied to all or part of the HP 8340A: In **STANDBY**, power is applied to the crystal oscillator's oven to maintain operating temperature and to the RAM circuits to maintain memory data; in the **ON** position, power is applied to the entire instrument. When the HP 8340A is connected to ac power for the first time, or after a prolonged period without power, the crystal oscillator's oven requires approximately 30 minutes to reach operating temperature (the red **OVEN** annunciator in the **ENTRY DISPLAY** will be lighted during this warm-up period). Power must always be available to the HP 8340A to keep the oven warm; therefore, when the instrument is not in use set the **POWER** switch to **STANDBY**, and do not interrupt the ac power.

When the **POWER** switch is changed from **STANDBY** to **ON**, the HP 8340A will automatically initiate an internal circuit check, then momentarily show the **HP-IB** address in the **ENTRY DISPLAY**, followed by setting the instrument functions to the last-entered values. If this sequence does not happen, press [**INSTR PRESET**] to initiate an instrument check, as described in Figure 3-12. If a warning annunciator lights at power-on, refer to the display Figures 3-3, 3-4, 3-5, and 3-6 for further instructions.

SWEEP OUTPUT is provided by a front panel BNC connector (and an identical rear panel BNC connector). The output voltage range for this connector is 0 to +10 volts dc. When the HP 8340A is sweeping, the **SWEEP OUTPUT** is 0 Vdc at the beginning of the sweep and +10 Vdc at the end of the sweep, regardless of sweep width. In **CW** mode, the **SWEEP OUTPUT** ranges from 0 Vdc at the 10 MHz minimum frequency of the HP 8340A, to 10 Vdc at the 26.5 GHz maximum frequency, with a proportional voltage for frequencies between 10 MHz - 26.5 GHz. Pressing [**CW**] then [**MANUAL**] locks the **CW** frequency but allows a full-range voltage output from the **SWEEP OUTPUT**, which is controlled by the rotary [**KNOB**] (useful, for example, when scaling an X-Y recorder). The output impedance at this **SWEEP OUTPUT** connector is nominally 1 k Ω .

Figure 3-13. Power Switch, Sweep Output

DESCRIPTION

These two keys select pulse and/or amplitude modulation of the RF output, and are used in conjunction with the front panel **PULSE** and **AM** BNC connectors (described in Figure 3-15). Table 1-1 (Specifications) lists all electrical parameters of these two modulation functions.

PANEL LAYOUT

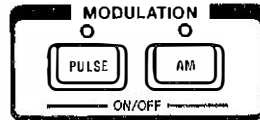

[PULSE] (HP-IB: PM1 turns on pulse modulation, PM0 turns off the function) activates the pulse modulation function. When pulse modulation is in effect, the RF output of the HP 8340A is turned on (full power selected) and off (>80 dB attenuation) at a rate determined by the pulse modulation input (described in Figure 3-15). Pulse and amplitude modulation can be in effect simultaneously (amplitude modulation is described in a following paragraph). Press **[PULSE]** a second time to turn off the function.

[SHIFT] [PULSE] has no effect on the HP 8340A.

[AM] (HP-IB: AM1 turns on amplitude modulation, AM0 turns off the function) activates the amplitude modulation function. Amplitude modulation allows the pre-attenuated RF output of the HP 8340A to be continuously and linearly varied between -30 dBm and the maximum power available, at a rate determined by the **AM** input (described in Figure 3-15). Amplitude and pulse modulation can be in effect simultaneously. Press **[AM]** a second time to turn off the function.

[SHIFT] [AM] (HP-IB: SHAM) activates the AM function and increases the ALC (automatic leveling control) bandwidth in the pulse modulation mode to reduce the settling time of the pulses. Settling time is the typical amount of time needed for the amplitude of the internally leveled RF pulse to come to within 10% of its final value after a change in the pulse amplitude has been initiated. Settling time values are listed in Table 1-1. The cost for the faster settling time obtained by **[SHIFT] [AM]** is a slight degradation of the pulse envelope, and a change of the minimum pulse repetition frequency from 100 Hz to 1 kHz.

Figure 3-14. Modulation

DESCRIPTION

The external pulse or amplitude modulation signals are applied to the HP 8340A at these two BNC connectors.

PANEL LAYOUT

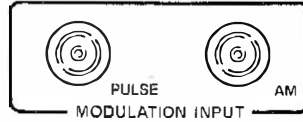

FUNCTIONS

PULSE MODULATION INPUT is TTL compatible; a TTL high input ($> +2$ volts) causes maximum selected RF power output, while a TTL low input causes minimum RF output (>80 dB RF on/off ratio). The pulse repetition frequency is dc to 20 MHz in non-leveled applications, 100 Hz to 5 MHz when internally leveled, or 1 kHz to 5 MHz when internally leveled in the extended bandwidth mode ([SHIFT] [AM]). Table 1-1 (Specifications) details the electrical requirements of the **PULSE** modulation input, and explains the subsequent effects on the RF output. The damage levels for this input are $\geq +12$ volts or ≤ -20 volts.

AM MODULATION INPUT accepts a -1 volt to $+1$ volt signal, at a frequency of dc to 100 kHz (3 dB bandwidth). With an **AM** input of 0 volts, the RF output level (the reference level) is unaffected; at -1 volts input the RF is shut off, and at $+1$ volts input the RF output is 100% (6 dB) higher than the reference level (hence there must be ≥ 6 dB of headroom between the reference power level and the maximum power level available at that frequency). The on (0 volt input) to off (-1 volt input) ratio is a function of power level and frequency, but is always greater than 20 dB. The amplitude of the RF output changes linearly as the **AM** input changes from -1 to $+1$ volts. Table 1-1 (Specifications) lists all electrical requirements of the **AM** input, and explains the subsequent effects on the RF output. Damage level for this input is $\geq +12$ volts or ≤ -12 volts.

Figure 3-15. Modulation Input

DESCRIPTION

Internal or external (crystal or power meter) power leveling is selected by these keys, which also select a band crossing diagnostic and allow direct linear modulator access. The external leveling BNC input connector is also described in this Figure.

PANEL LAYOUT

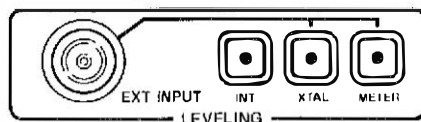

FUNCTIONS

EXT INPUT BNC connector is the input port for an external leveling signal. The signal requirements are listed in Table 1-1. See the Operating Guide “Externally Leveling the HP 8340A Synthesized Sweeper,” located at the end of Section III, for detailed information about external leveling procedures.

[INT] (HP-IB: A1) selects internal leveling of the HP 8340A. Table 1-1 (Specifications) lists the maximum leveled power for each frequency band, and other power function restraints.

[SHIFT] [INT] (HP-IB: SHA1) allows single-stepping through each frequency band, and is used with **[SHIFT] [XTAL]** for a band crossing diagnostic routine. See **[SHIFT] [XTAL]** for an explanation of how these two shifted functions interact, and see Section VIII (Service) for a comprehensive explanation of this diagnostic function.

[XTAL] (HP-IB: A2) activates external crystal leveling of the HP 8340A. A portion of the RF output (derived from a coupler or a splitter) must be detected, with the detected output being delivered to the **EXT INPUT** BNC connector, thus forming an output-input feedback loop (the loop typically has 7 kHz bandwidth). Press **[XTAL]**, and “ATN: -xx dB, REF: -xx.xx dBV” (where x is the last-entered value) will appear in the entry display. Then use the rotary **[KNOB]** or the numerical keys with the **[dB(m)]** terminator key to change the REFERENCE level, and the **[STEP]** keys to change the ATN while watching either the POWER dBm display (allowing for losses in the coupler or splitter) or an attached power meter. The “Externally Leveling the HP 8340A Synthesized Sweeper” operating guide (HP Part Number 08340-90041) located at the end of this Section fully explains crystal leveling and shows typical equipment interconnections.

[SHIFT] [XTAL] (HP-IB: SHA2) activates a band crossing diagnostic function. Press **[SHIFT] [XTAL]** to enable the diagnostic, then press **[SHIFT] [INT]**, which will cause the HP 8340A to sweep to the first band crossing point and stop at that point. Press **[SHIFT] [INT]** again and the HP 8340A will sweep to the next band crossing point and stop at that point. Continue pressing **[SHIFT] [INT]** to single-step through each of the bands. Press **[SHIFT] [XTAL]** again to cancel this diagnostic routine. **[SHIFT] [XTAL]** used without **[SHIFT] [INT]** will cause the HP 8340A to stop at the end of a sweep.

Figure 3-16. Leveling (1 of 2)

[METER] (HP-IB: A3) selects external power meter leveling of the HP 8340A. A portion of the RF output must be measured by a power meter, with the power meter also connected to the **EXT INPUT** BNC connector to form an output-input feedback loop (typical bandwidth 0.7 Hz). Press **[METER]**, which will cause (after a brief delay) "ATN: -xx dB, REF: -xx.xx dBV" (where x is the last-entered value) to appear in the ENTRY DISPLAY. Use the rotary **[KNOB]** or the numerical keys with the **[dB(m)]** terminator key to set the REFERENCE level, and the **[STEP]** keys to set the ATN while watching either the POWER dBm display (allowing for coupler or splitter losses) or the power meter. An operating guide, "Externally Leveling the HP 8340A Synthesized Sweeper" (HP Part Number 08340-90041), located at the end of this Section fully explains power meter leveling.

[SHIFT] [METER] (HP-IB: SHA3) bypasses the ALC (automatic leveling control) to allow direct control of the linear modulator circuit, which is useful when very narrow pulses are being generated in pulse modulation mode. In this mode there is no limit on the minimum pulse repetition frequency. Press **[SHIFT] [METER]**, which will cause "ATN: -xx dB, MOD: x.x dB" (where x is the last-entered value) to appear in the ENTRY DISPLAY. To set the power, place the HP 8340A in CW mode, or in pulse modulation mode with pulses wider than 2 μ sec. Then use the **[STEP]** keys to set the ATN (attenuator), and the rotary **[KNOB]** or numerical keys with **[dB(m)]** terminator key to set the MOD (linear modulator), as follows: Set MOD entry at 0 dB, increment ATN until the POWER dBm display shows a level 5 dB to 15 dB higher than the desired output power, then reduce the power to the desired level by changing the MOD value. The POWER dBm display shows actual power when the HP 8340A is in CW or wide-pulse pulse modulation modes; this actual power changes very little as the pulse width is narrowed, even though the POWER dBm reading drops. Therefore, at this point reduce the pulse width to the desired value and ignore the POWER dBm display. The ATN and MOD values in the ENTRY DISPLAY also have a limitation: Although the ATN displayed value is always accurate, the MOD becomes saturated in the top 10 dB (approximately) of its range at which point no change occurs in the true power; furthermore, the modulation entry is only approximately calibrated. Consequently, rely on the POWER dBm display for the true power level instead of the MOD value. See Figures 3-14 and 3-15 for additional pulse modulation information. **[SHIFT] [METER]** can also be used as a diagnostic function for the ALC circuits, as described in Section VIII (Service).

Figure 3-16. Leveling (2 of 2)

DESCRIPTION

All RF power functions, except for power level, are controlled by these keys; and the RF output port is contained in this group.

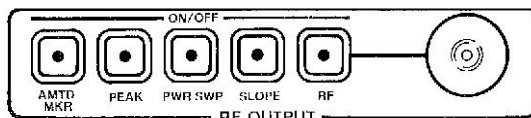

FUNCTIONS

[AMTD MKR] (HP-IB: AK1 turns on amplitude markers, AK0 turns off amplitude markers) changes intensity-dot markers to amplitude-spike markers on a CRT display. When the markers are activated after an **[INSTR PRESET]**, markers **[M1]** . . . **[M5]** appear as intensified dots on a CRT display; press **[AMTD MKR]** to change all of the markers to amplitude spikes. Press **[AMTD MKR]** again to return to intensified-dot markers.

[SHIFT] [AMTD MKR] (HP-IB: SHAK) causes an instantaneous execution of the peaking function, when the HP 8340A is in CW or manual mode. This is a one-time implementation of peaking, where the function is quickly turned on then turned off. Peaking is explained in the next paragraph.

[PEAK] (HP-IB: RP1 turns on peaking, RP0 turns off peaking) aligns the output filter (SYTM) so that its passband is centered on the RF output, in CW or manual-sweep mode. Peaking is used to obtain the maximum available power and spectral purity, and best pulse envelopes, at a given frequency. Press **[PEAK]**, and the HP 8340A will automatically peak the present CW frequency, and continue to peak new frequencies as they are entered by the **[KNOB]**, or the **[STEP]** keys, or the numerical keys (with a terminator key). If **[PEAK]** is on for an extended time, the peaking function will automatically re-peak every 7 minutes. Press **[PEAK]** again to cancel this function. When **[PEAK]** is activated, the HP 8340A performs a coarse alignment, and then a fine alignment that begins at the final setting of the coarse search; **[SHIFT] [AMTD MKR]** initiates only a fine alignment which begins at the present instrument setting. **[SHIFT] [AMTD MKR]** is faster, but has less adjustment range than **[PEAK]**. **[SHIFT] [PEAK]**, described in the next paragraph, is a related function.

[SHIFT] [PEAK] (HP-IB: SHRP) is a more extensive version of peaking, **[PEAK]**, which requires a fraction of a second to implement, aligns the output filter with a single CW frequency, while **[SHIFT] [PEAK]** aligns all of the YTM tracking calibration constants and requires 5-10 seconds to implement. Use **[SHIFT] [PEAK]** to enhance the power output and spectral purity of swept modes, and to improve tracking performance (especially in harsh environments having wide temperature variations). Press **[SHIFT] [PEAK]**, which will cause "AUTO TRACKING" to appear in the ENTRY DISPLAY. "AUTO TRACKING" will disappear after 5-10 seconds when the calibration has been completed.

Figure 3-17. RF Output (1 of 3)

[PWR SWEEP] (HP-IB: PS1 turns on power sweep, PS0 turns off the function) allows the power output to be swept when the HP 8340A is in CW mode. This is the procedure:

1. Select a CW frequency, as explained in Figure 3-7.
2. Press **[SHIFT] [PWR SWEEP]**, which decouples the attenuator (ATN) from the automatic leveling control (ALC) and displays the ATN and ALC values in the ENTRY DISPLAY. The ALC range is -20 dBm to an upper value that depends on frequency (see Table 1-1 for the specifications).
3. Use the **[STEP]** keys to set the value of the ATN, and the **[KNOB]** or numerical keys with **[dB(m)]** terminator key to set the ALC for the starting power level, as shown in the POWER dBm display. The ALC value should be as close as possible to -20 dBm to achieve the widest-span power sweep.
4. Set the **[SWEEP TIME]**, as explained in Figure 3-7.
5. Press **[PWR SWEEP]**, which will cause "POWER SWEEP: x.xx dB/SWP" (where x is the last-entered value) to appear in the ENTRY DISPLAY. Use either the **[KNOB]**, the **[STEP]** keys, or the numerical keys with the **[dB(m)]** terminator key to select the span of the power sweep (positive values only, ranging from 0.0 to 40.00 dB/SWP).
6. Select SWEEP and TRIGGER, as described in Figure 3-11.

If only narrow-span power sweeps are necessary, the ATN does not need to be decoupled from the ALC: Omit steps 2 and 3 in the preceding text, using instead the **[POWER LEVEL]** key to set the initial power output. This simplified procedure restricts the range of power sweeps to that of the coupled ALC, which is -9.95 dBm to the maximum power permitted (maximum power depends on frequency, as listed in Table 1-1).

[SHIFT] [PWR SWEEP] (HP-IB: SHPS) decouples the attenuator (ATN) from the automatic leveling control (ALC), as explained in the preceding function. Recouple the ATN and ALC by pressing **[POWER LEVEL]**.

[SLOPE] (HP-IB: SL1 turns on the slope function, SL0 turns off the function) compensates for system or cable losses at high frequencies by linearly increasing the power output as the frequency increases. Press **[SLOPE]**, which will cause "RF SLOPE: xx.xx dB/GHz" (where x is the last-entered value) to appear in the ENTRY DISPLAY. Use either the **[KNOB]**, the **[STEP]** keys, or the numerical keys with the **[dB(m)]** terminator key to set any positive slope value between 0.000 to 1.500 dB/GHz. Press **[SLOPE]** again to cancel this function. **[SLOPE]** functions in dB/GHz units, but SL (the equivalent HP-IB code) functions in the fundamental units of dB/Hz. Therefore, the SL code should be programmed as SLmdt, where m is 0 (off) or 1 (on), d is the numerical value in dB/Hz, and t is either "DB" or the ASCII LF terminator. For example, to obtain a slope of 1.5 dB/GHz use this procedure:

1. $1.5 \text{ dB/GHz} = 1.5 \text{ dB} / 1,000,000,000 \text{ Hz}$
2. $1.5 \text{ dB} / 1\text{E}9 \text{ Hz} = 1.5\text{E}-9 \text{ dB/Hz}$
3. Programming code is then "SL11.5E-9 DB".

Figure 3-17. RF Output (2 of 3)

[SHIFT] [SLOPE] (HP-IB: SHSL) allows front panel control of the mechanical attenuator (ATN). Press **[SHIFT] [SLOPE]**, which will cause "ATN: x dB" (where x is the last-entered value) to appear in the ENTRY DISPLAY. Use the **[STEP]** keys, or the numerical keys with any terminator key to change the attenuator value within the range 0 dB to -90 dB in 10 dB steps. Keyboard entries are automatically rounded to the nearest 10 dB. The clicking sound heard after each attenuator change is the attenuator pad being mechanically switched into the RF output path.

[RF] (HP-IB: RF1 turns on RF output, RF0 turns off RF output) turns the RF output on or off. Press **[RF]**, which will cause "- OFF -" to appear in the POWER dBm display and will cause the output power to be turned off (output = -110 dBm). Press **[RF]** again to turn on the RF output, restoring the last-entered power output.

[SHIFT] [RF] (HP-IB: SHRF) disables the ALC (automatic leveling control) to allow direct control of the linear modulator circuit. This is useful when very narrow pulses are being generated in pulse modulation mode. When **[SHIFT] [RF]** is engaged, there is no limit on the minimum pulse repetition frequency.

The following message will be displayed in the ENTRY DISPLAY: "**POWER SEARCH: X.XX dB**" (where X.XX is the last-entered value).

To set the power level, place the HP 8340A in CW mode, or in pulse modulation mode with pulses wider than 2 usec, and use the **[STEP]** keys, the rotary **[KNOB]** or the data entry keypad with the **[dBm]** terminator key to enter the power level desired. The POWER dBm display shows the actual power when the instrument is in CW or pulse modulation mode. The accuracy of the **POWER dBm** display is typically the same as when the instrument is leveled. Table 1-1 contains this information under **PULSE MODULATION** specifications, **ACCURACY OF INTERNALLY LEVELED RF PULSE Vp (relative to CW mode level)**. The actual power changes very little as the pulse width is narrowed, even though the POWER dBm reading drops. Therefore, at very narrow pulse widths ignore this reading.

[SHIFT] [RF] can also be used as a diagnostic function of the ALC circuits (refer to the ALC loop description/troubleshooting in the beginning of the RF Section for more information).

RF OUTPUT CONNECTOR consists of a precision APC 3.5 male connector. The output impedance, SWR, and other electrical characteristics are listed in Table 1-1 (Specifications). When making connections, carefully align the center conductor elements, then rotate the knurled barrel of the RF OUTPUT CONNECTOR while holding the connecting component still, until a firm contact is obtained.

Considerable care must be used when working with APC-3.5 connectors: Do not deform the connector by excessive tightening force, and do not allow the connector to get corroded, scratched, or dirty. If cleaning is necessary, use a firm, lintless brush only; do not use any cleaning solvents, since solvents can chemically damage the plastic bead that supports the center conductor. If this conductor is mechanically degraded in any way, high frequency losses will occur. Section VIII (Service) describes replacement procedures for this connector.

Figure 3-17. RF Output (3 of 3)

DESCRIPTION

The electrical characteristics and requirements of the rear panel BNC connectors are listed in this Figure.

PANEL LAYOUT

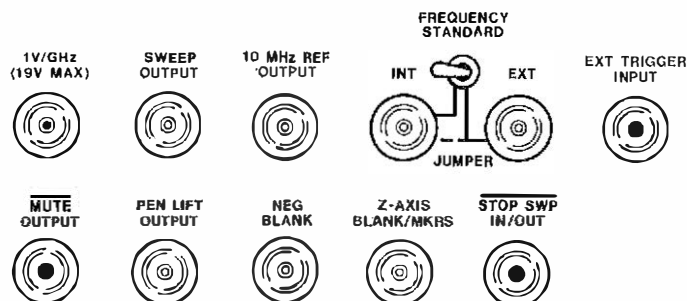

FUNCTIONS

1 V/GHz outputs a voltage that is proportional to the RF output frequency, with a ratio of 1 volt output per 1 GHz RF frequency. The maximum output voltage is 19 V; hence, this BNC output is not proportional above 19 GHz. Load impedance should be $\geq 4 \text{ k}\Omega$. Accuracy is $1 \text{ V/GHz} \pm 1\% \pm 2 \text{ mV}$. An output voltage ratio of 0.5 volts/GHz can be achieved by clipping two jumpers on the A28 SYTM board (see Section VIII), which would allow a proportional output for the entire 10 MHz to 26.5 GHz frequency span of the HP 8340A.

SWEEP OUTPUT is provided by a rear panel BNC connector, and an identical front panel BNC connector. The output voltage range for this connector is 0 to +10 volts dc. When the HP 8340A is sweeping, the **SWEEP OUTPUT** is 0 Vdc at the beginning of the sweep and +10 Vdc at the end of the sweep regardless of sweep width. In CW mode, the **SWEEP OUTPUT** ranges from 0 Vdc at the 10 MHz minimum frequency of the HP 8340A, to 10 Vdc at the 26.5 GHz maximum frequency, with a proportional voltage for frequencies between 10 MHz - 26.5 GHz. Pressing [CW] then [MANUAL] locks the CW frequency but allows a full-range voltage output from the SWEEP OUTPUT, controlled by the rotary [KNOB] (useful, for example, when scaling an X-Y recorder). The output impedance at this **SWEEP OUTPUT** connector is nominally $1 \text{ k}\Omega$. Figure 3-13 also describes SWEEP OUTPUT.

10 MHz REF OUTPUT provides a 0 dBm, 10 MHz signal derived from the internal frequency standard of the HP 8340A. Test instruments are connected to this $50 \text{ }\Omega$ BNC connector while the 10 MHz crystal oscillator is being adjusted (as described in Section VIII, Service, of this Manual), or this can be the master clock reference output for a network of instruments.

Figure 3-18. Rear Panel BNC Connectors (1 of 2)

INT / EXT SWITCH & BNC CONNECTORS select either the internal (INT) 10 MHz crystal oscillator frequency standard, or an external (EXT) frequency standard to be used as the master timebase for the HP 8340A. To select the internal standard, place the switch in the **INT** position and connect a jumper cable between the **INT** and **EXT** BNC connectors (the **INT** BNC is now outputting 10 MHz at +3 dBm). To use an external standard, disconnect the jumper, change the switch to **EXT**, and connect the external source to the **EXT** BNC connector. The external source must be either 5 MHz \pm 50 Hz, or 10 MHz \pm 100 Hz, and provide 0 to +10 dBm into the 50 Ω BNC connector. When the switch is in the **EXT** position the amber **EXT REF** annunciator lights in the ENTRY DISPLAY.

EXT TRIGGER INPUT triggers the start of a sweep. Trigger signal must be >2 volts (10 V maximum), and wider than 0.5 μ sec. Nominal input impedance is 2 k Ω . Figure 3-11 describes the front panel procedures that are involved in sweep operations.

MUTE OUTPUT causes the servo motor of an X-Y recorder to pause while the HP 8340A crosses a frequency band switchpoint. The X-Y recorder Operating Guide, located at the end of Section III, explains the interaction of recorders with the HP 8340A.

PENLIFT OUTPUT provides a blanking signal at band crossing switchpoints if [**SHIFT**] [**LINE**] has been activated on the front panel. The output at switchpoints (and during retrace) is +15 volts from 10 k Ω ; during sweeps, the output is 0 volts from 10 Ω . This output is operational only for sweep times \geq 5 seconds. Figure 3-11 explains the [**SHIFT**] [**LINE**] front panel function that activates **PENLIFT OUTPUT**, and the X-Y recorder Operating Guide located at the end of Section III contains detailed interconnection information.

NEG BLANKING provides a negative rectangular pulse (approximately -5 volts into 2 k Ω) during retrace and band switchpoints when the HP 8340A is sweeping.

Z-AXIS BLANK/MKRS supplies a positive rectangular pulse (approximately +5 volts into 2 k Ω) during the retrace and band switchpoints when the HP 8340A is sweeping. This output also supplies a -5 volt pulse when the RF output is coincident with a marker frequency (intensity markers only, as explained in Figure 3-9).

STOP SWP IN/OUT abruptly stops a sweep when this input is grounded. Retrace does not occur, and the sweep will resume when this input is ungrounded. The open circuit voltage at this connector is TTL High, and is internally pulled low when the HP 8340A stops its sweep. Externally forcing this input High will neither cause damage nor disrupt normal HP 8340A operation.

Figure 3-18. Rear Panel BNC Connectors (2 of 2)

DESCRIPTION

The two rear panel RF Output connectors (one standard, one an option) are described in this Figure.

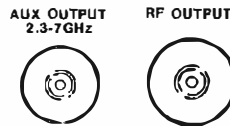
PANEL LAYOUT**FUNCTIONS**

AUX OUTPUT 2.3 - 7 GHz is a type N female connector that provides a 0 dBm Output from the HP 8340A's fundamental YIG oscillator (the higher frequencies obtainable from the HP 8340A are multiples of this oscillator). Impedance of this connector is 50 Ω (nominal).

RF OUTPUT is an optional rear panel RF output connector that is functionally equivalent to the standard front panel RF output connector (which is described in Figure 3-17). Option 004 is a rear panel RF output with attenuator, and Option 005 is a rear panel RF output without attenuator. The specifications for each option are listed in Table 1-1 (Section I of this Manual). Contact the nearest HP Sales and Service Office for information about retrofitting an HP 8340A with one of these options.

Figure 3-19. Rear Panel RF Output

DESCRIPTION

The procedures for connecting the HP 8340A to other HP-IB instruments is explained in this Figure.

PANEL LAYOUT

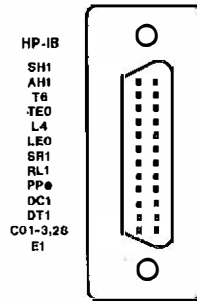

FUNCTIONS

The HP-IB interface connector allows the HP 8340A to be connected to any other instrument or device on the HP-IB bus. A complete illustration of pin configuration and signals on the HP-IB interface connector is given in Section II of this Manual.

All HP-IB instruments are interconnected with special HP-IB cables and adapters. These special cables, shown in the accompanying illustration, assure that the proper voltage levels and timing relations are maintained on the HP-IB bus. The adapters are principally extension devices for instruments that have recessed or crowded HP-IB connectors.

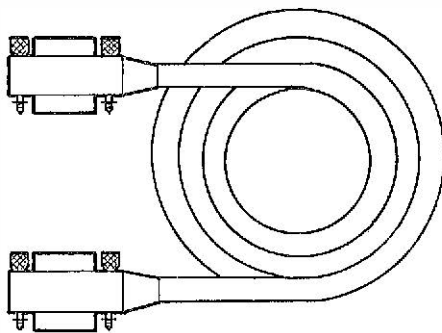

HP-IB Interface Cables Available

| HP-IB Cable Part Numbers | Lengths |
|--------------------------|-----------------|
| HP 10833A | 1 m (3.3 ft.) |
| HP 10833B | 2 m (6.6 ft.) |
| HP 10833C | 4 m (13.2ft.) |
| HP 10833D | 0.5 m (1.6 ft.) |

As many as 14 HP-IB instruments can be connected to the HP 8340A (15 total instruments in the system). The cables can be interconnected in a "star" pattern (one central instrument, with HP-IB cables emanating from that instrument like spokes in a wheel), or in a linear pattern (like boxcars in a train), or in any combination pattern. However, there are certain restrictions:

- Each instrument must have a unique HP-IB address ranging from 0-30 (decimal). Figure 3-12 ([SHIFT] [LOCAL]) explains HP-IB addressing for the HP 8340A.

Figure 3-20. HP-IB Connector (1 of 2)

- In a two-instrument system that uses just one HP-IB cable, the cable length must not exceed 4 metres (13 feet).
- When more than two instruments are connected on the bus, the cable length to each instrument must not exceed 2 metres (6.5 feet) per unit.
- The total cable length between all units cannot exceed 20 metres (65 feet).

Hewlett-Packard manufactures HP-IB Extender instruments (Models 37201A, 37203A/L) that overcome the range limitations imposed by the cabling rules. These extenders allow twin-pair cable operation up to 1000 metres (3,280 feet), and telephone modem operation over any distance. HP Sales and Service offices can provide additional information on HP-IB extenders.

The codes next to the HP-IB connector describe the HP-IB electrical capabilities of the HP 8340A, using IEEE Std 488-1978 mnemonics (HP-IB, GP-IB, IEEE-488, and IEC-625 are all electrically equivalent). Briefly, the mnemonics translate as follows:

SH1: Source Handshake, complete capability.

AH1: Acceptor Handshake, complete capability.

T6: Talker; capable of basic talker, serial poll, and unaddress if MLA.

TE0: Talker, Extended address; no capability.

L4: Listener; capable of basic listener, and unaddress if MTA.

LE0: Listener, Extended address; no capability.

SR1: Service Request, complete capability.

RL1: Remote Local, complete capability.

PP0: Parallel Poll, no capability.

DC1: Device Clear, complete capability.

DT1: Device Trigger, complete capability.

C0, 1, 2, 3, 28: Controller capability options; C0, no capabilities; C1 system controller; C2, send IFC and take charge; C3, send REN; C28, send I.F. messages.

E1: Electrical specification indicating open collector outputs.

These codes are completely explained in the **IEEE Std 488-1978** document, published by The Institute of Electrical and Electronic Engineers, Inc. 345 East 47th Street, New York, New York 11017.

Figure 3-20. HP-IB Connector (2 of 2)

DESCRIPTION

This connector interfaces the HP 8340A to the HP 8410B/C Network Analyzer.

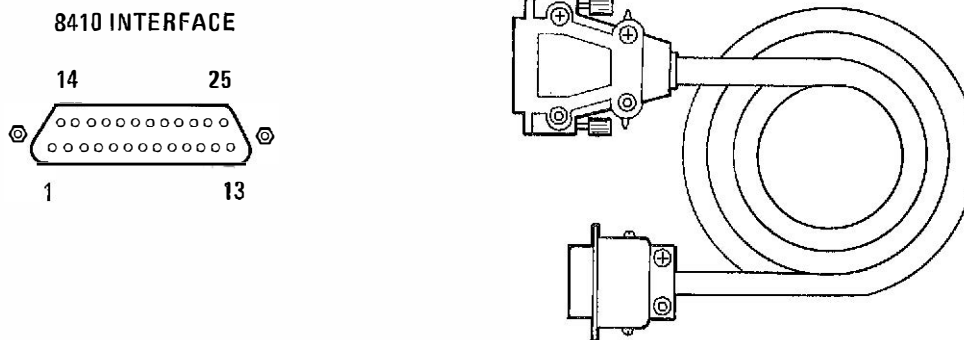
PANEL LAYOUT**FUNCTIONS**

Connect the HP 8410B/C Network Analyzer to this port on the HP 8340A, using a Source Control Cable (HP Part Number 08410-60146). An Operating Guide at the end of this Section explains HP 8410B/C to HP 8340A interconnections. Section VIII (Service) describes the electrical requirements for this connector.

This connector has pins that duplicate several rear panel functions, including EXT TRIGGER INPUT, MUTE OUTPUT, PENLIFT OUTPUT, NEG BLANK, and Z-AXIS BLANK/MKRS. There is also a pin input for a switch closure to execute the UP key function, which is used to step through a series of saved instrument states. Additional information is contained in Section VIII, as well as in the HP 8410B/C Operating and Service Manual.

Figure 3-21. HP 8410 Interface (1 of 2)

Pin Description of the 8410 Interface Connector

| Pin No. | Description | Pin. No. | Description |
|---------|-----------------------------|----------|----------------------------|
| 1 | Not Used | 13 | Not Used (O) |
| 2 - | Marker Pulse (O) | 14 - | Blanking (O) |
| 3 - | Pen Lift Request (I) | 15 - | Marker Pulse Request (I) |
| 4 - | Sweep Alternate (O) | 16 - | Retrace (O) |
| 5 - | Stop Fwd. Sweep Request (I) | 17 - | Alternate Sweep Enable (O) |
| 6 | +5 Volt (100 ma MAX) (O) | 18 - | Stop Sweep Request (I) |
| 7 - | RF Blanking (O) | 19 | Digital Ground (I/O) |
| 8 - | RF Blank Request (I) | 20 - | Blanking Pulse Request (I) |
| 9 - | External Trigger Input (I) | 21 - | Counter Trigger (O) |
| 10 + | Pen Lift (O) | 22 - | Step Up Advance (I) |
| 11 - | Recorder Mute (O) | 23 - | Inverse Pen Lift (O) |
| 12 | Not Used (O) | 24 + | 8410 External Trigger (O) |
| 13 | Not Used | 25 | Not Used |
| 14 - | Blanking (O) | | |

- Negative Logic (True is logical "0")
 + Positive Logic
 (I) Input
 (O) Output

Figure 3-21. HP 8410 Interface (2 of 2)

DESCRIPTION

The HP 8755C Scalar Network Analyzer is connected to the HP 8340A at this connector.

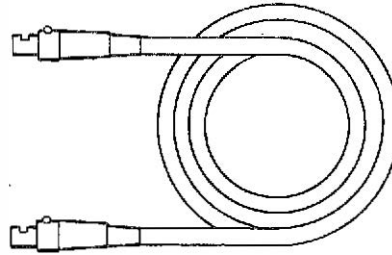
PANEL LAYOUT**FUNCTIONS**

Connect the HP 8755C Scalar Network Analyzer to the HP 8340A at this connector, using Interface Cable 8120-3174, to provide the alternate sweep function. An Operating Guide at the end of Section III explains the HP 8755C to HP 8340A interconnections. The pin configuration and electrical requirements for this connector are described in Section VIII (Service) of this Manual.

Figure 3-22. HP 8755C Interface

DESCRIPTION

Maintenance of the filter element for the fan is described in this Figure.

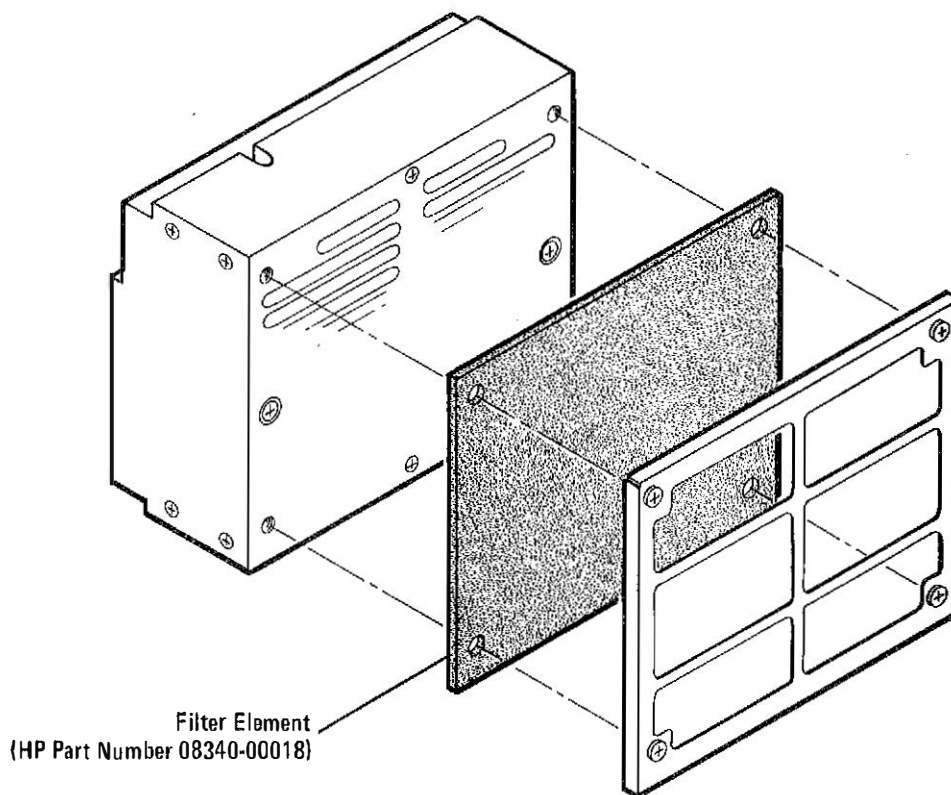
PANEL LAYOUT**FUNCTIONS**

The foam filter element requires regular inspection and cleaning. The cooling fan for the HP 8340A is powerful, and pulls a large amount of air through its filter element; subsequently, the filter element collects dust, smoke, and other contaminants even from environments that seem quite clean. To prevent impaired cooling from a dirt-clogged filter, it is imperative that the filter be inspected regularly, and replaced as needed. (Filter replacement is recommended; cleaning, by vacuuming or washing and drying, is recommended only if a replacement filter is not available.). Section VI (Replaceable Parts) contains a complete parts listing for the fan, in the B1 Fan Assembly pictorial.

Figure 3-23. Fan Assembly

INSERT IN FRONT OF THE OPERATING INFORMATION MANUAL IN SECTION III, OPERATION

Page 3-42, Figure 3-24 (SERIAL PREFIX 2520A):

Under **PANEL LAYOUT**, replace the line module illustration with the following:

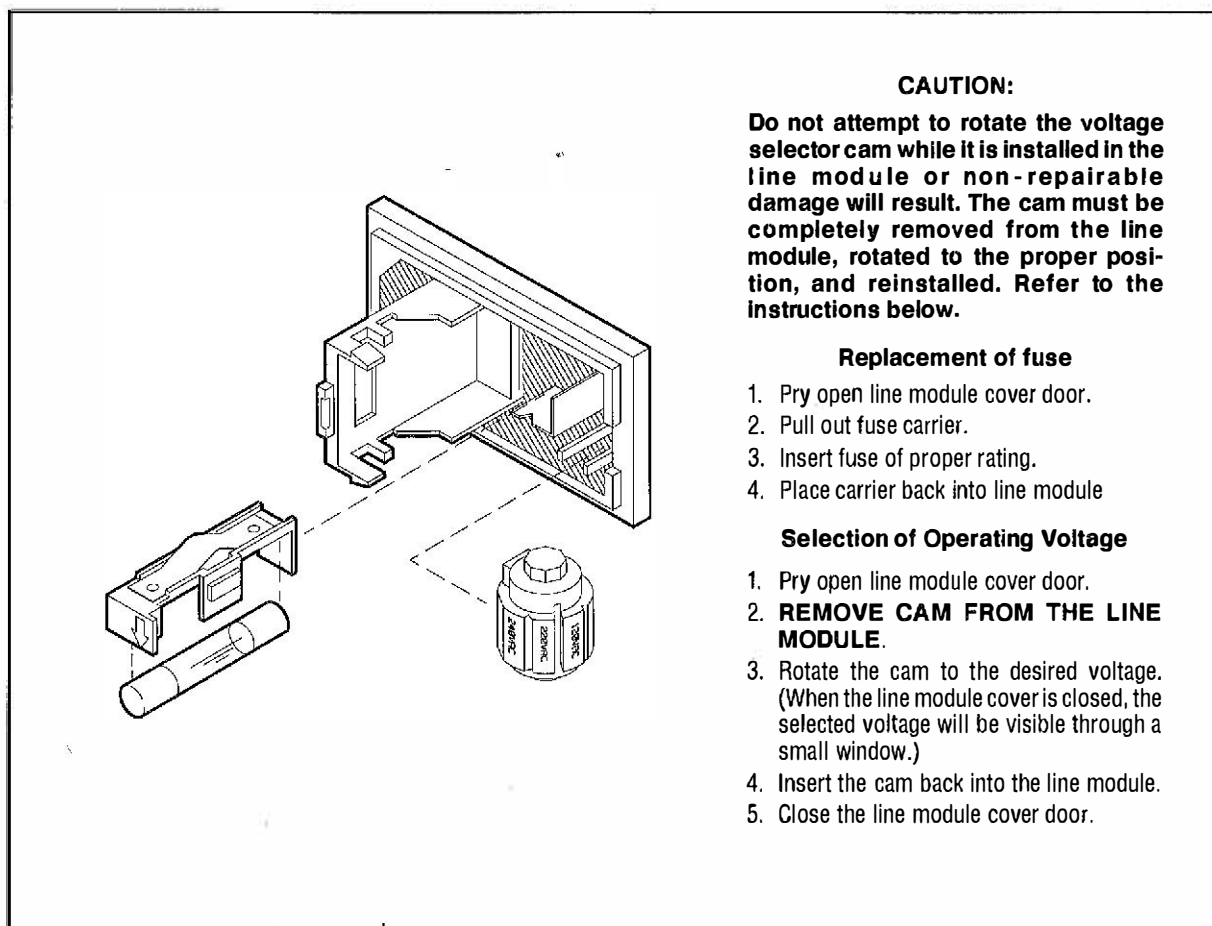

CAUTION:

Do not attempt to rotate the voltage selector cam while it is installed in the line module or non-repairable damage will result. The cam must be completely removed from the line module, rotated to the proper position, and reinstalled. Refer to the instructions below.

Replacement of fuse

1. Pry open line module cover door.
2. Pull out fuse carrier.
3. Insert fuse of proper rating.
4. Place carrier back into line module

Selection of Operating Voltage

1. Pry open line module cover door.
2. **REMOVE CAM FROM THE LINE MODULE.**
3. Rotate the cam to the desired voltage. (When the line module cover is closed, the selected voltage will be visible through a small window.)
4. Insert the cam back into the line module.
5. Close the line module cover door.

Figure 3-24. Power Line Module

Under **FUNCTIONS**, change the second paragraph to read:

“To determine the module’s voltage setting, first measure the locally available ac power source (ac mains). The HP 8340A requires either 100, 120, 220, or 240 volts with a tolerance of $\pm 10\%$. The instrument also requires an ac frequency of 47.5 Hz to 66 Hz. Some installations may need an autotransformer and/or a frequency converter to meet the voltage and frequency requirements. After obtaining suitable voltage and ac frequency, position the line voltage selector **cam** as shown in the accompanying illustration. The selected voltage shows through a small window when the line module cover door is closed.”

DESCRIPTION

The line power module contains a safety fuse, and a PC card that is used as a switch to match the HP 8340A's power supply to the locally available ac power.

PANEL LAYOUT

RECEPTACLE FOR PRIMARY POWER CORD

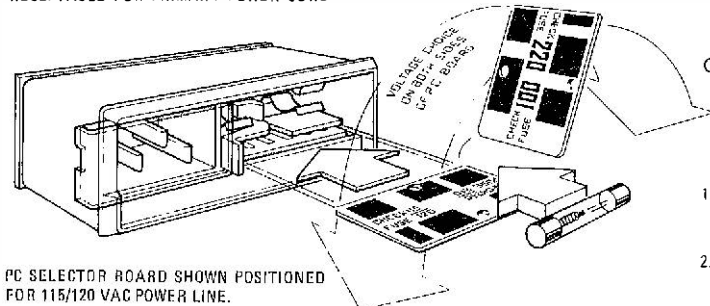

PC SELECTOR BOARD SHOWN POSITIONED FOR 115/120 VAC POWER LINE.

OPERATING VOLTAGE APPEARS IN MODULE WINDOW.

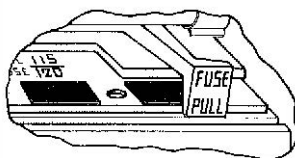

CHECKING THE LINE POWER MODULE

SELECTION OF OPERATING VOLTAGE

1. SLIDE OPEN POWER MODULE COVER DOOR AND PULL FUSE-PULL LEVER TO LEFT TO REMOVE FUSE.
2. PULL OUT VOLTAGE-SELECTOR PC BOARD. POSITION PC BOARD SO THAT VOLTAGE NEAREST ACTUAL LINE VOLTAGE LEVEL WILL APPEAR IN MODULE WINDOW. PUSH BOARD BACK INTO ITS SLOT.
3. PUSH FUSE-PULL LEVER INTO ITS NORMAL RIGHT-HAND POSITION.
4. CHECK FUSE TO MAKE SURE IT IS OF CORRECT RATING AND TYPE FOR INPUT AC LINE VOLTAGE. FUSE RATINGS FOR DIFFERENT LINE VOLTAGES ARE PRINTED ADJACENT TO THE POWER MODULE.
5. INSERT CORRECT FUSE IN FUSEHOLDER.

FUNCTIONS

The HP 8340A requires a maximum of 500 VA of electrical power (40 VA in STANDBY) that is delivered to the instrument through the line power module. The module setting must match the locally available voltage, and be fused to provide a measure of safety to the instrument and the operator.

To determine the module's voltage setting, first measure the locally available ac power source. The HP 8340A requires either 100, 120, 200, or 240 volts with a tolerance of $\pm 10\%$. The HP 8340A also requires an ac frequency of 47.5 Hz to 66 Hz (400 Hz can be used in Option 003 instruments). Some installations may need an autotransformer and/or frequency converters to meet the voltage and frequency requirements. After obtaining suitable voltage and ac frequency, position the PC selector card as shown in the accompanying illustration.

The proper fuse rating also corresponds to the voltage selection, and these ratings are printed on the rear panel of the HP 8340A adjacent to the line power module (the fuses are also listed in Section II (Installation) of this Manual).

Appropriate power line cords are listed in Section II (Installation).

Figure 3-24. Power Line Module

HP-IB PROGRAMMING

Introduction

HP-IB, the Hewlett-Packard Interface Bus, is the instrument-to-instrument communication system between the HP 8340A and up to 14 other instruments. Any instrument having HP-IB capability can be interfaced to the HP 8340A, including non-HP instruments that have "GPIB," "IEEE-488," "ANSI MC1.1," or "IEC-625" capability (these are common generic terms for HP-IB; all are electrically equivalent although IEC-625 uses a unique connector). This portion of the manual specifically describes interfacing the HP 8340A to one very special type of instrument: a computer.

Interconnective Cabling

Figure 3-20 shows the HP 8340A's rear-panel HP-IB connector and suitable cables, and describes the procedures and limitations for interconnecting instruments. Cable length restrictions, also described in Figure 3-20, must be observed to prevent transmission line propagation delays that might disrupt HP-IB timing cycles.

Instrument Addresses

Each instrument in an HP-IB network must have a unique address, ranging in value from 00-30 (decimal). The default address for the HP 8340A is 19, but this can be changed by the [SHIFT] [LOCAL] function as described in Figure 3-12 (the examples in this section use 19 as the address for the HP 8340A). Other instruments use a variety of procedures for setting the address, as described in their operating manuals, but typically either a rear panel switch or a front panel code is used.

HP-IB Instruments Nomenclature

HP-IB instruments are categorized as "listeners," "talkers," or "controllers," depending on their current function in the network.

LISTENER is a device that is capable of receiving data or commands from other instruments. Any number of instruments in the HP-IB network can simultaneously be listeners.

TALKER is a device that is capable of transmitting data or commands to other instruments. To avoid confusion, an HP-IB system allows only one device at a time to be an active talker.

CONTROLLER is an instrument, typically a computer, that is capable of managing the various HP-IB activities. Only one device at a time can be an active controller.

Programming the HP 8340A

The HP 8340A can be entirely controlled by a computer (although the line POWER switch must be operated manually). All functions that are initiated by front panel keystrokes (local operation) can also be initiated by an HP-IB computer; additionally, several functions are possible only by computer (remotc) control. Computer programming procedures for the HP

8340A involve selecting an HP-IB command statement, then adding the specific HP 8340A programming codes to that statement to achieve the desired operating conditions. The programming codes can be categorized into two groups: Those that mimic front panel keystrokes, and the unique codes that have no front panel equivalent.

In the programming explanations that follow, specific examples are included that are written in a generic dialect of the BASIC language. BASIC was selected because the majority of HP-IB computers have BASIC language capability; however, other languages can also be used. Hewlett-Packard publishes a series of Programming Notes that contain computer-specific, language-specific information for those wishing to use another language; contact the nearest HP Sales and Service Office (listed inside of the back cover) for a list of HP 8340A Programming Notes.

HP-IB Command Statements

Command statements form the nucleus of HP-IB programming; they are understood by all instruments in the network and, when combined with instrument-specific codes, they provide all management and data communications instructions for the system.

An explanation of the fundamental command statements follows. However, some computers use a slightly different terminology, or support an extended or enhanced version of these commands. Consider the following explanations as a starting point, but for detailed information consult the BASIC language reference manual, the I/O programming guide, and the HP-IB manual for the particular computer being used.

Syntax drawings accompany each statement: All items enclosed by a circle or oval are computer-specific terms that must be entered exactly as described; items enclosed in a rectangular box are names of parameters used in the statement; and the arrows indicate a path that generates a valid combination of statement elements.

Here are the eight fundamental command statements:

ABORT abruptly terminates all listener/talker activity on the interface bus, and prepares all instruments to receive a new command from the controller. Typically, this is an initialization command used to place the bus in a known starting condition. The syntax is

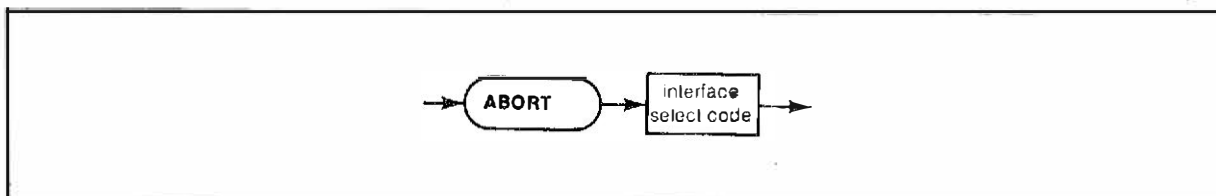

where the interface select code is the computer's HP-IB I/O port, which is typically port 7. Some BASIC examples:

```
10 ABORT 7
```

```
100 IF V > 20 THEN ABORT 7
```

Related statements used by some computers:

```
ABORTIO (used by HP-80 series computers)
HALT
RESET
```

REMOTE causes an instrument to change from local control to remote control. In remote control, the front panel keys are disabled (except for the [**LOCAL**] key and the POWER switch), and the amber REMOTE annunciator is lighted in the ENTRY DISPLAY. The syntax is

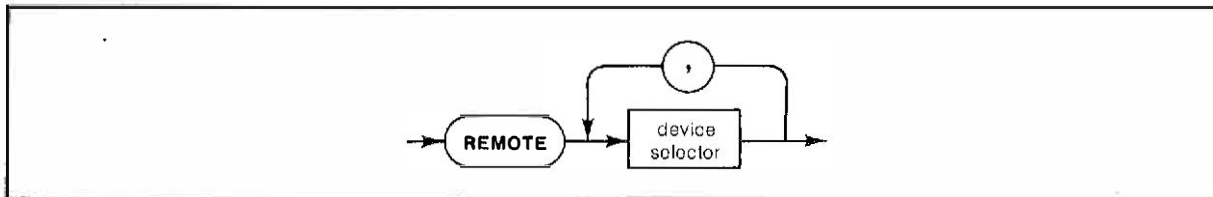

where the device selector is the address of the instrument appended to the HP-IB port number. Typically, the HP-IB port number is 7, and the default address for the HP 8340A is 19, so the device selector is 719. Some BASIC examples:

```
10 REMOTE 7
```

which prepares all HP-IB instruments for remote operation (although nothing appears to happen to the instruments until they are addressed to talk), or

```
10 REMOTE 719
```

which effects the HP-IB instrument located at address 19, or

```
10 REMOTE 719, 721, 726, 715
```

which effects four instruments that have addresses 19, 21, 26, and 15.

Related statements used by some computers:

RESUME

LOCAL LOCKOUT can be used in conjunction with REMOTE to disable the front panel [**LOCAL**] key. With the [**LOCAL**] key disabled, only the controller (or a hard reset by the POWER switch) can restore local control. The syntax is

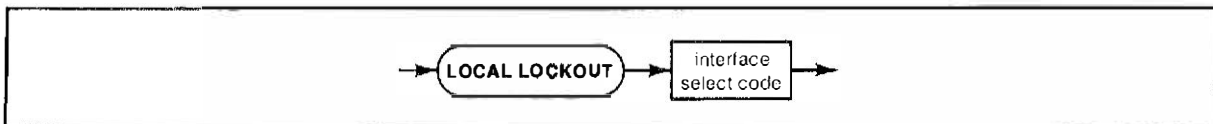

A BASIC example:

```
10 REMOTE 719
20 LOCAL LOCKOUT 7
```

LOCAL is the complement to REMOTE, causing an instrument to return to local control with a fully enabled front panel. LOCAL syntax is

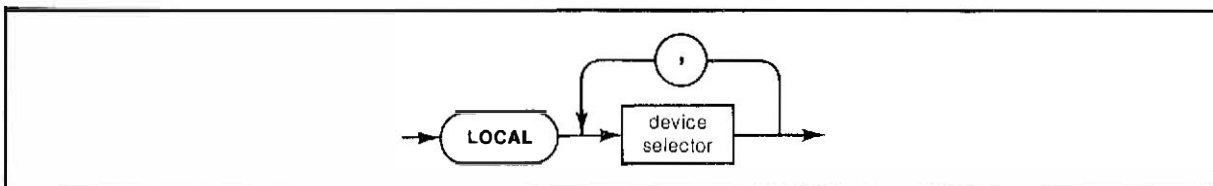

Some BASIC examples:

10 LOCAL 7

which effects all instruments in the network, or

10 LOCAL 719

for an addressed instrument (address 19).

Related statements used by some computers:

RESUME

CLEAR causes all HP-IB instruments, or addressed instruments, to assume a "cleared" condition, with the definition of "cleared" being unique for each device. For the HP 8340A:

1. Both status bytes are reset to zero.
2. All pending output-parameter operations, such as those associated with the **OA**, **OP**, and **OR** codes, are halted.
3. The parser (the software that interprets the programming codes) is reset, and now expects to receive the first character of a programming code.

The syntax is

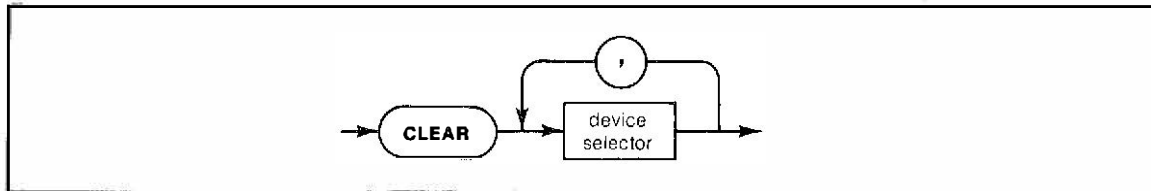

Some BASIC examples:

10 CLEAR 7

to clear all HP-IB instruments, or

10 CLEAR 719

to clear an addressed instrument.

Related statements used by some computers:

RESET
CONTROL
SEND

TRIGGER initiates a single event, such as a single sweep or an instantaneous measurement, from all instruments or an individually addressed instrument. If the HP 8340A is in analog-sweep mode TRIGGER starts the sweep; if in CW, manual sweep, or fast phaselock (code FP) mode TRIGGER increments the frequency. When the upper frequency limit is reached (either the stop frequency for swept modes, or 26.5 GHz for CW mode) the next TRIGGER command will initiate a retrace to the starting frequency. The syntax is

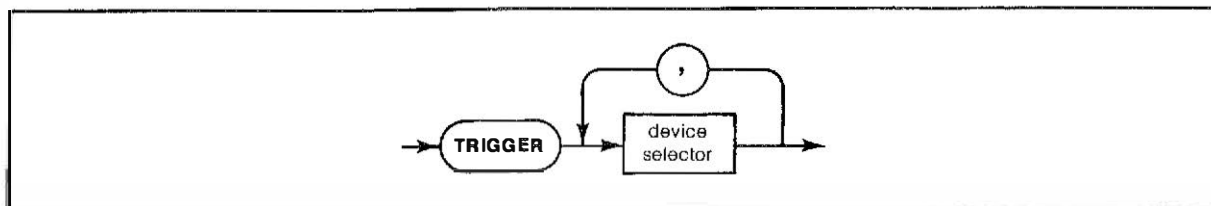

A BASIC example:

to simultaneously trigger all HP-IB instruments, or

```
100 TRIGGER 719
```

to trigger an instrument at address 19, or

```
100 TRIGGER 719, 721, 712
```

to trigger instruments at addresses 19, 21, and 12.

Related statements used by some computers:

```
RESUME  
SEND
```

The preceding statements are primarily management commands that do not incorporate instrument-specific programming codes. The following two statements do incorporate programming codes, and are used for data communication.

OUTPUT is used to send function commands and data commands from the controller to the addressed instrument. The syntax is

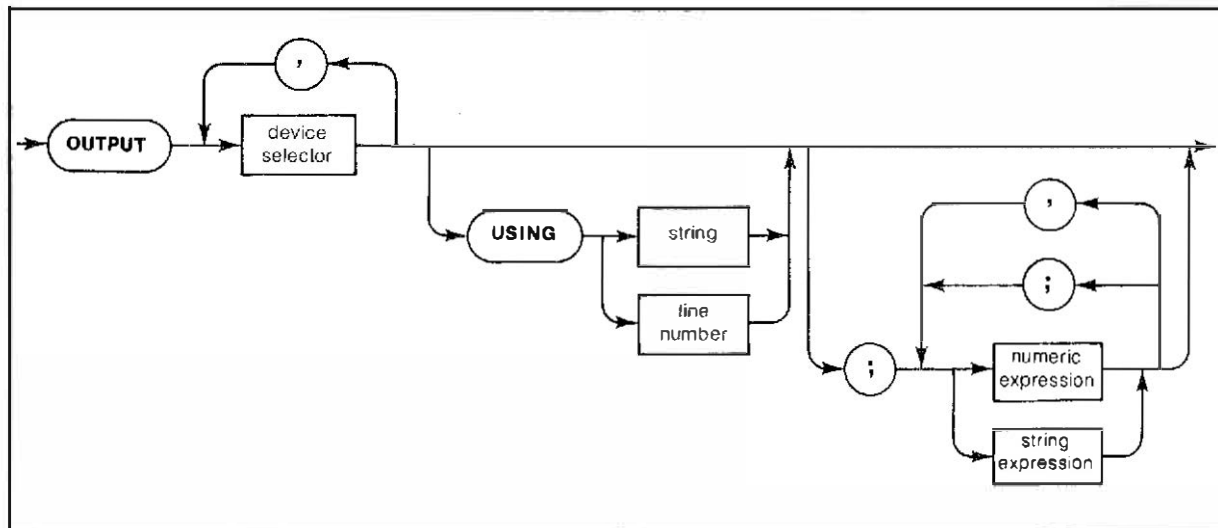

where USING is a secondary command that formats the output in a particular way, such as binary or ASCII representation of numbers. The USING command is followed by "image items" that precisely define the format of the output; these image items can be a string of code characters, or a reference to a statement line in the computer program. Image items are explained in the programming codes where they are needed. Notice that this syntax is virtually identical with the syntax for the ENTER statement that follows. A BASIC example:

```
100 OUTPUT 719; "programming codes"
```

The many programming codes for the HP 8340A are listed in Tables 3-1 and 3-2, and are explained in the Programming Codes subsection.

Related statements used by some computers:

CONTROL
CONVERT
IMAGE
IOBUFFER
TRANSFER

ENTER is the complement to OUTPUT, and is used to transfer data from the addressed instrument to the controller. The syntax is

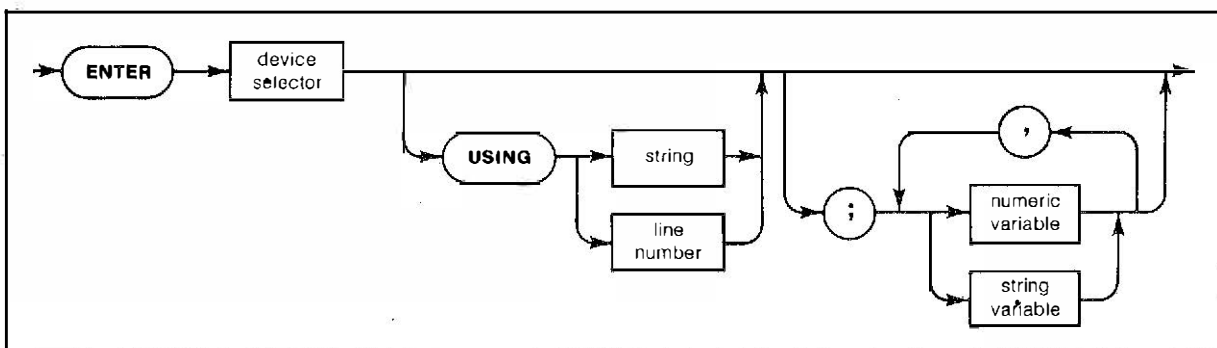

ENTER is always used in conjunction with OUTPUT, such as:

```
100 OUTPUT 719; "... programming codes ..."  
110 ENTER 719; "... complementary codes ..."
```

ENTER statements are commonly formatted, which requires the secondary command USING and the appropriate image items. The most-used image items involve end-of-line (EOL) suppression, binary inputs, and literal inputs. For example,

```
100 ENTER 719 USING "#, B"; A, B, C
```

suppresses the EOL sequence (#), and indicates that variables A, B, and C are to be filled with binary (B) data. As another example,

```
100 ENTER 719 USING "#, 123A"; A$
```

suppresses EOL, and indicates that string variable A\$ is to be filled with 123 bytes of literal data (123A). (Note: Be careful when using byte-counting image specifiers, because if the requested number of bytes does not match the actual number available data might be lost, or the program might enter an endless wait state.)

The suppression of the EOL sequence is frequently necessary to prevent a premature termination of the data input. When not specified, the typical EOL termination occurs when an ASCII LF (line feed) is received. However, the LF bit pattern could coincidentally occur randomly in a long string of binary data, where it might cause a false termination. Also, the bit patterns for the ASCII CR (carriage return), comma, or semicolon might cause a false termination. Suppression of the EOL causes the computer to accept all bit patterns as data, not commands, and relies on the HP-IB EOI (end or identify) line for correct end-of-data termination.

The various programming codes that are associated with the ENTER statement are listed in Tables 3-1 and 3-2, and are explained in the Programming Codes subsection.

Related statements used by some computers:

CONVERT
IMAGE
IOBUFFER
ON TIMEOUT
SET TIMEOUT
TRANSFER

This completes the HP-IB Command Statements subsection. The following material explains the HP 8340A programming codes, and shows how they are used with the OUTPUT and ENTER HP-IB command statements.

HP 8340A Programming Codes

Table 3-1 lists the HP 8340A programming codes arranged by function, and Table 3-2 lists the codes alphabetically. Notice in the Tables that several codes correspond to keys on the front panel of the HP 8340A: All front panel operations (except the POWER switch) can be duplicated by a remote computer program, and those are the programming codes that are used to replace the keystrokes. There are also several programming codes listed in the Tables that are unique to HP-IB operation. The next two subsections describe all of these codes, first by explaining how front panel operations can be duplicated, and then explaining the unique HP-IB operations.

Programs that Duplicate Front Panel Operations

Any HP 8340A operation that can be established by pressing keys on the front panel can be duplicated by a computer program, with the exception of the POWER switch function. This is the procedure:

1. Determine the keystroke sequence needed for the desired operation. For example, this sequence establishes a 2.3 GHz CW signal at -30 dBm:

[INSTR PRESET] [CW] [2] [.] [3] [GHz] [POWER LEVEL] [-] [3] [0] [dB(m)]

Table 3-2. HP 8340A Programming Codes (1 of 4)

| Code | Operation Performed | Equivalent Key | Ref. Figure |
|----------|----------------------------|----------------|-------------|
| A1 | Leveling, internal | [INT] | 3-16 |
| A2 | Leveling, external | [XTAL] | 3-16 |
| A3 | Leveling, power meter | [METER] | 3-16 |
| AK m | Amplitude marker | [AMTD MKR] | 3-17 |
| AL m n | Alternate state | [ALT] | 3-12 |
| AM m | Amplitude modulation | [AM] | 3-14, 3-15 |
| AS m | Alternate state select | | |
| AT d | Attenuator | | |
| AU | Auto | [Hz/Auto] | 3-10 |
| BC | Change frequency band | | |
| CF d t | Center frequency | [CF] | 3-7 |
| CS | Clear both status bytes | | |
| CW d t | CW frequency | [CW] | 3-7 |
| DB | dB(m) terminator | [GHz/dB(m)] | 3-10 |
| DF d t | Delta frequency | [ΔF] | 3-7 |
| DN | Down step | [▼] | 3-8 |
| DU m | Display updating (= SHS1) | | |
| EF | Entry Display off | [ENTRY OFF] | 3-8 |
| EK | Enable rotary knob | | |
| FA d t | Start frequency | [START FREQ] | 3-7 |
| FB d t | Stop frequency | [STOP FREQ] | 3-7 |
| FP * | Fast phaselock | | |
| GZ | GHz terminator | [GHz/dB(M)] | 3-10 |
| HZ | Hz terminator | [Hz/AUTO] | 3-10 |
| IF | Increment frequency | | |
| IL 123b | Input learn data | | |
| IP | Instrument preset | [INSTR PRESET] | 3-12 |
| KR | Keyboard release | | |
| KZ | kHz terminator | [kHz/msec] | 3-10 |
| M0 | Marker off (=M0) | [OFF] | 3-9 |
| M1 d t | Marker 1 on | [M1] | 3-9 |
| M2 d t | Marker 2 on | [M2] | 3-9 |
| M3 d t | Marker 3 on | [M3] | 3-9 |
| M4 d t | Marker 4 on | [M4] | 3-9 |
| M5 d t | Marker 5 on | [M5] | 3-9 |
| MC | Marker to center frequency | [MKR - CF] | 3-9 |
| MD m | Marker delta | [MKR Δ] | 3-9 |
| MO | Marker off (=M0) | [OFF] | 3-9 |
| MP m | Marker sweep, M1-M2 | [MKR SWEEP] | 3-9 |
| MS | milliseconds terminator | [kHz/msec] | 3-10 |
| MZ | MHz terminator | [MHz/sec] | 3-10 |
| NA 1b | Network analyzer configure | | |
| OA (d) | Output active parameter | | |
| OB (d) | Output next band frequency | | |
| OC (3d) | Output coupled parameters | | |
| OD * | Output diagnostic values | | |
| OF (d) | Output fault values | | |
| OI (19a) | Output identification | | |
| OK (d) | Output last lock frequency | | |

Table 3-2. HP 8340A Programming Codes (2 of 4)

| Code | Operation Performed | Equivalent Key | Ref. Figure |
|-----------|------------------------------------|-----------------------|-------------|
| OL (123b) | Output learn data | | |
| OM (8b) | Output mode data | | |
| OP (d) | Output interrogated parameter | | |
| OR (d) | Output power level | | |
| OS (2b) | Output status bytes | | |
| PL d t | Power level | [POWER LEVEL] | 3-7 |
| PM m | Pulse modulation | [PULSE] | 3-14, 3-15 |
| PS m | Power sweep | [PWR SWP] | 3-17 |
| RB 1b | Remote rotary knob | | |
| RC n | Recall instrument state | [RECALL] [0-9] | 3-12 |
| RE 1b | Extended status byte mask | | |
| RF m | RF output on/off | [RF] | 3-17 |
| RM 1b | Status byte mask | | |
| RP m | RF peaking | [PEAK] | 3-17 |
| RS | Reset sweep | | |
| S1 | Sweep, continuous | [CONT] | 3-11 |
| S2 | Sweep, single | [SINGLE] | 3-11 |
| S3 | Sweep, manual | [MANUAL] | 3-11 |
| SC | seconds terminator | [MHZ/sec] | 3-10 |
| SF d t | Step frequency size | | |
| SG | Sweep, single | | |
| SH | Shift prefix | [SHIFT] | 3-7 |
| SHA1 | Jump to next bandcross | [SHIFT] [INT] | 3-16 |
| SHA2 m | Band crossing diagnostic | [SHIFT] [XTAL] | 3-16 |
| SHA3 d t | Access linear modulator | [SHIFT] [METER] | 3-17 |
| SHAK | Immediate YTM peak | [SHIFT] [AMTD MKR] | 3-17 |
| SHAM m | Pulse modulation enhancement | [SHIFT] [AM] | 3-14 |
| SHCF d t | Set frequency step size | [SHIFT] [CF] | 3-7 |
| SHCW * | CW increment resolution | [SHIFT] [CW] | 3-7 |
| SHFA d t | Display multiplier | [SHIFT] [START FREQ] | 3-7 |
| SHFB d t | Display offset | [SHIFT] [STOP FREQ] | 3-7 |
| SHM1 | Diagnostic: M/N, 20/30 frequency | [SHIFT] [M1] | 3-9 |
| SHM2 | Diagnostic: band, YO | [SHIFT] [M2] | 3-9 |
| SHM3 | Diagnostic: VC01, VC02 frequencies | [SHIFT] [M3] | 3-9 |
| SHM5 | Turn off diagnostics | [SHIFT] [M5] | 3-9 |
| SHMO | Turn off all markers | [SHIFT] [OFF] | 3-9 |
| SHMP | Marker sweep, M1-M2 | [SHIFT] [MKR SWEEP] | 3-9 |
| SHPL d t | Set power level step | [SHIFT] [POWER LEVEL] | 3-7 |
| SHPS d t | Decouple ATN, ALC | [SHIFT] [PWR SWP] | 3-17 |
| SHRC | Remove save-lock | [SHIFT] [RECALL] | 3-12 |
| SHS1 m | Blank displays | [SHIFT] [CONT] | 3-11 |
| SHS3 | Display fault diagnostic | [SHIFT] [MANUAL] | 3-11 |
| SHSL d t | Control reference level | [SHIFT] [SLOPE] | 3-17 |
| SHST d t | ZOOM function | [SHIFT] [SWEEP TIME] | 3-7 |
| SHSV | Lock save/recall | [SHIFT] [SAVE] | 3-12 |
| SHRP | Tracking calibration | [SHIFT] [PEAK] | 3-17 |
| SHT1 | Test displays | [SHIFT] [FREE RUN] | 3-11 |
| SHT2 m | Bandcrossing penlift | [SHIFT] [LINE] | 3-11 |
| SHT3 | Display unlock indicators | [SHIFT] [EXT] | 3-11 |

Table 3-2. HP 8340A Programming Codes (3 of 4)

| Code | Operation Performed | Equivalent Key | Ref. Figure |
|----------|--------------------------------|---------------------|-------------|
| SHGZ d t | IO channel | [SHIFT] [GHz/dB(m)] | 3-10 |
| SHMZ d t | IO subchannel | [SHIFT] [MHz/sec] | 3-10 |
| SHKZ d t | Write to IO | [SHIFT] [kHz/msec] | 3-10 |
| SHHZ | Read from IO | [SHIFT] [Hz/AUTO] | 3-10 |
| SL m d t | Power slope | [SLOPE] | 3-17 |
| SM d t | Sweep, manual | | |
| SN d t | Steps, maximum | | |
| SP d t | Set power step size | | |
| ST d t | Sweep time | [SWEEP TIME] | 3-7 |
| SV n | Save instrument state | [SAVE] [1-9] | 3-12 |
| SW m | Swap network analyzer channels | | |
| T1 | Trigger, free run | [FREE RUN] | 3-12 |
| T2 | Trigger, line | [LINE] | 3-12 |
| T3 | Trigger, external | [EXT] | 3-12 |
| TI b (b) | Test HP-IB interface | | |
| TL d t | Time limit | | |
| TS | Take sweep | | |
| UP | Up step | [▲] | 3-8 |

Note: The HP 8340A automatically upshifts codes entered in lower case, and ignores spaces placed between codes groups. The warning message "HP-IB SYNTAX ERROR" appears in the ENTRY DISPLAY if an error is made in the programming format, and the HP 8340A will ignore the unrecognized code characters. (The HP 8340A also clears HP-IB DIO line 8, which sometimes is used as a parity bit; HP-IB lines are explained later in this Section.)

The lower-case letters listed after the codes indicate typical suffix parameters, as follows:

If no suffix follows a code in this Table, the code represents either a self-contained, immediate execute function, or one of the terminator codes that scale and define the associated numerical data.

- a** indicates that alphanumeric ASCII characters are associated with this code.
- b** indicates binary information consisting of 8-bit bytes. Typically, binary information is transmitted by using either the computer's CHR\$(s) function (which converts a decimal number to a string of binary bytes), such as
100 OUTPUT 719; "... code..."&CHR\$(decimal)

where the "&" concatenates the CHR\$(s) function to the programming code (and prevents an end-of-line terminator from being placed between the code and the data), or for codes that require strings of binary data an image specifier can be used; for example:
100 OUTPUT 719; "... programming code...";
110 OUTPUT 719 USING "#, B"; byte(s)

The final semicolon in line 100 inhibits an end-of-line sequence from the computer (an EOL must not separate code from data). The "#" in line 110 suppresses EOL that might occur between data bytes or from a coincidental data bit pattern that mimics an EOL sequence, and the "B" indicates that the subsequent variables represent binary data.

Table 3-2. HP 8340A Programming Codes (4 of 4)

d indicates decimal data, which is allowed any of these data formats:

- single digit: ±d
- Integer, decimal: ±d***d
- Real, decimal: ±d***.d***d
- Exponential, decimal: ±d***d.d***dE±dd

m indicates that a "1" or a "0" must follow the code letters, where the 1 suffix is usually used to turn on the function, and the 0 suffix turns off the function.

n is a single digit, 1-9 for SV and 0-9 for RC, which indicates the desired memory register.

t indicates that a terminator is required. Typically, the programming codes GZ, MZ, KZ, HZ, DB, SC, and MS are used as terminators because they also serve as units scalars. Alternatively, a comma or an ASCII LF (decimal 10) can be used as a terminator, which will cause the HP 8340A to scale the corresponding function to the fundamental units of Hertz, seconds, or dB(m).

(...) parenthesis indicate codes that cause the HP 8340A to output information for a subsequent input by the computer, with the format of that information being indicated by the parenthetical letters. For example, code listing OC(3d) indicates that 3 decimal values should be read as a result of the OC command:

```
100 OUTPUT 719; "OC"
110 ENTER 719; A, B, C
```

As another example, code listing OM(8b) indicates that 8 binary bytes should be read:

```
100 OUTPUT 719; "OM"
110 ENTER 719 USING "#, B"; B1, B2, B3, B4, B5, B6, B7, B8
```

(The image parameters in line 110 are explained in the preceding "b - binary data" section.)

* follows the codes that have special suffix requirements; consult the detailed explanation of the code for further information.

FA12GZ FB18GZ PL-65DB STAU (followed by RETURN or END LINE)

The HP 8340A should immediately respond to your commands with, in this example, a 12 GHz start frequency, 18 GHz stop frequency, power level of -65 dBm, and a sweep time set to auto (auto selects the fastest possible sweep rate for a given frequency span).

The preceding applications of the OUTPUT command are sufficient for writing computer programs that duplicate all front panel operations. The next subsection explains programming codes that do not have an equivalent key on the front panel.

Unique HP-IB Programming Codes

Several programming codes are available which do not have an equivalent front panel key; these codes are listed in Table 3-2 and described here, in alphabetical order (the lower case letters that follow each code mnemonic are explained in Table 3-2).

AS_m Alternate State Select, is primarily used when the HP 8340A is operating in certain network analyzer systems. AS is always used in conjunction with alternate state mode ([ALT], Figure 3-12) where it causes an abrupt change from one operational state to the other. Use AS when automatic alternation does not occur (for example, when CW mode is used for one or both operational states), or when it might be necessary to interrupt the alternating operation.

First, establish alternating operation between the present operating configuration (called the "foreground" state) and one of the previously SAVED operating configurations (called the "background" state). For example, code AL13 activates alternating operation between the foreground and background states, with the background state being derived from the contents of memory register 3 (the code parameters are AL_nx, where n=1/0 to activate/deactivate alternating operation, and x=1-9 indicates the memory register that will be transferred to the background register).

With alternating mode in effect, AS is used to abruptly change the operating state: AS0 causes the present HP 8340A operation (whether that operation is foreground or background) to abruptly halt, retrace to the beginning of the foreground state, and begin operating under the foreground configuration; AS1 causes the present operation to abruptly halt, retrace to the beginning of the background state, and begin operating under the background configuration. After the AS-initiated foreground or background change has been completed, the previously established alternating state operation resumes. A BASIC example:

```

100 REM PREPARE BACKGROUND STATE, SAVE IN REGISTER 3
110 OUTPUT 719; "... (programming codes) ...SV3"
120 REM
130 REM PREPARE FOREGROUND STATE, AND ALTERNATE
140 OUTPUT 719; "... (programming codes) ...AL13"
150 REM
160 REM ABRUPTLY CHANGE STATES IF NECESSARY
170 IF X > Y THEN OUTPUT 719; "AS1"
180 IF X < Y THEN OUTPUT 719; "AS0"

```

(X and Y in lines 170 and 180 are arbitrary variables for a hypothetical test.)

ATd Attenuator, allows the attenuator to be set remotely, and is used when the attenuator is uncoupled from the ALC (SHSL initiates the uncoupling). The standard attenuator (see the attenuator options listed in Section I) has a range of 0 to -90 dB in 10 dB increments; set the attenuator by using the code ATxDB, where x is the numerical value (the HP 8340A will round values to the nearest 10 dB) and DB is the terminator. A BASIC example:

```
100 OUTPUT 719; "AT-40DB"
```

BC Band Change, causes the HP 8340A to advance to the next frequency bandcrossing point. The BC code is used in two situations: 1) It is used when the HP 8340A is in network analyzer mode (the NA programming code), or 2) it is used when automatic bandcrossing has been disabled by the SHA21 code (in this case, the BC code functions identically to the SHA1 code; bandcross disabling and the SHA1/SHA2 functions are described in Figure 3-16).

CS Clear Status bytes, resets to zero the 16 bits in the two status bytes. Any status bit that is in the process of being set, but was deferred pending completion of some function, will also be cleared by CS. Status bytes, along with the CS code, are explained under the OS (Output Status byte) code.

DUm Display Updating, blanks (DU0) or unblanks (DU1) the front panel displays of the HP 8340A, and is identical in function to SHS1m ([SHIFT] [CONT], which is described in Figure 3-11). In automated systems the displays of the HP 8340A might be redundant, and can be blanked to reduce visual distractions for the operator. A BASIC example:

```
100 OUTPUT 719; "DU0"
```

If DU1 is output while the HP 8340A is in the middle of a sweep, the sweep will abruptly stop, retrace, and then resume sweep operations.

EK Enable Knob, activates the rotary [KNOB] on an otherwise remote HP 8340A front panel. Once the [KNOB] is enabled it is automatically coupled to the presently active function, such as:

```
100 OUTPUT 719; "CWEK"          ([KNOB] adjusts CW frequency)
```

```
200 OUTPUT 719; "PLEK"          ([KNOB] adjusts Power Level)
```

In the above examples, the CW and PL function codes were output along with EK to explicitly specify the active function; since no data accompanied the function codes, the last-used data values (or the IP default values) will be re-established. EK can also be output alone:

```
300 OUTPUT 719; "EK"
310 OUTPUT 719; "CF70MZ"
320 PAUSE
330 OUTPUT 719; "DF1MZ"
340 PAUSE
350 OUTPUT 719; "ST50MS PL-25DB"
360 PAUSE
```

EK always controls the active function; hence, at line 320 the **[KNOB]** controls the center frequency (initially at 70 MHz); at line 340 the **[KNOB]** controls the delta frequency (initially at 1 MHz); and at line 360 the **[KNOB]** controls the power level (initially at -25 dBm). Notice at line 360 that the **[KNOB]** controls PL, not ST, because PL is the last-activated function.

- FP** Fast Phaselock, is used when the fastest possible frequency transition is necessary between CW frequencies. FP can be used for fast transitions between steps in a stepped CW sweep, or it can be used when the CW frequencies must be rapidly changed to any value in the 10 MHz to 26.5 GHz frequency span of the HP 8340A.

FP achieves rapid frequency transition by limiting some of the normal HP 8340A features: The plotter control functions are disabled, the 0-10 volt sweep ramp is frozen, and the HP 8340A does not wait for a complete locking of the phase lock loop oscillators before releasing the HP-IB handshake. The FP code must have a numerical suffix (14 characters maximum) in Hz units, without any terminator code (ASCII "LF," normally sent by the computer, is the only allowable terminator), that sets the starting frequency. A BASIC example of a stepped CW sweep:

```
100 OUTPUT 719; "IP SF1KZ CW"
110 OUTPUT 719; "FP1E9"
120   FOR J = 1 TO 100
130   TRIGGER 719
140   NEXT J
150 GOTO 110
```

Line 100 sets the step size (SF) to 1 kHz, and causes the HP 8340A to enter CW mode (the unspecified CW frequency at this point will be the last used CW frequency, or the IP default value). Line 110 initiates fast phaselock mode, and establishes a starting CW frequency of 1E9 Hz (1×10^9 Hz, or 1 GHz). At this point in the program, the 8340A is outputting 1 GHz CW but will not increment until line 130 is reached. Line 150 causes a retrace to 1 GHz.

For irregular frequency steps use a variable to represent the numerical data, such as:

```
100 FOR N = 1 TO 4
110 READ A
120 OUTPUT 719; "FP";A
130 NEXT N
140 DATA 1E7, 1E8, 1E9, 1E10
```

Line 140 contains the list of frequencies (in Hz units; hence, 10 MHz, 100 MHz, 1 GHz, and 10 GHz) which are read in line 110. The semicolon between the "FP" and A (an arbitrary variable) in line 120 signifies to the computer that a terminator should not separate the code from the variable.

- IF** Increment Frequency, is similar to the HP-IB commands TRIGGER and GET (group execute trigger). IF must be used to trigger the SN function, and can be used to increment SM and other CW frequency functions (however, IF cannot be used to trigger FP). For example:

```
100 OUTPUT 719; "SF1GZ CW1GZ"
110 FOR N = 1 TO 20
120 OUTPUT 719; "IF"
130 NEXT N
```

The step size and the starting CW frequency are both set to 1 GHz in line 100. Lines 110 to 130 cause the CW frequency to increment 20 times (i.e., a 1-21 GHz stepped sweep).

IL123b Input Learn data, is used in conjunction with OL (Output Learn data) to save/recall various operating configurations of the HP 8340A. IL/OL is similar to the SAVE/RECALL functions, except with IL/OL the active function in use prior to OL storage is once again active after the IL restoration (no function is active after a RECALL), and there is virtually no limit to the number of instrument states that can be stored (SAVE/RECALL has a capacity of 9 memory registers, located in the HP 8340A; IL/OL data is stored in the computer's mass storage device). IL is explained under the OL programming code.

KR Keyboard Release, is used with the NA code. If NA bit 1 is set True (=1), the HP 8340A front panel keys are in a lock-and-release mode. In this mode, the keyboard is locked (disabled) after any one key has been pressed, and remains locked until released by the KR code. The typical loop program involves three steps: 1) Determine which key was pressed by using the OM code; 2) process the key closure information; 3) use KR to release the keyboard, and return to step 1.

NAb Network Analyzer configuration, establishes the operating modes that are used when the HP 8340A is interfaced with certain network analyzers. The modes are established by adding a binary or decimal number to the NA code, where the bits of the number are deciphered as follows:

Bit 0 set true (1):

Enable network analyzer mode with the following features:

1. Enable group-execute-trigger (GET) to start a sweep after a mid-sweep update, if in analog sweep mode.
2. Use Stop Frequency to calculate the end of the band.
3. Disable HP 8340A detection of sweep event markers, bandcrossing points, and sweep end point.
4. Do binary search to set sweep reset DAC.
5. Issue end of sweep SRQ for mid-sweep update.
6. Disable automatic alternation when alternating in manual or CW non-swept mode.
7. Ignore BC following mid-sweep updates, until next GET.

Bit 1 set true (1): Enable keyboard hold off, released by KR.

Bit 2 set true (1): Disable "HP-IB SYNTAX ERROR" annunciator that would otherwise appear in the ENTRY DISPLAY.

Bits 3-7: Not used.

Bit 0 is set true by decimal "1," bit 1 is set by decimal "2," and bit 2 is set by decimal "4." A BASIC example that sets bits 0, 1, and 2 true:

```
100 OUTPUT 719; "NA"&CHR$(7)
```

In this example, the binary value of decimal 7 (CHR\$(7)) is concatenated to the NA code (&). Alternatively, a formatted OUTPUT statement could be used to output the same binary information:

```
100 OUTPUT 719 USING "2A, B"; "NA", 7
```

The image specifier "2A, B" indicates that two literal characters will be output, followed by a single binary byte.

Consult the Operating Guide for the specific network analyzer being used for detailed interfacing information.

- OA(d)** Output Active parameter, allows the computer to read the numerical value of the presently active HP 8340A function. The active function is the last-used function, and appears in an unblanked ENTRY DISPLAY. A BASIC example:

```
100 OUTPUT 719; "FA65MZ FB75MZ PL10DB ST1SC"
110 OUTPUT 719; "OA"
120 ENTER 719;A
130 PRINT "ACTIVE PARAMETER = "; A
```

Sweep time is the active parameter, because it was the last-entered function (line 100). The OA value read by the computer (read in line 120, and assigned to arbitrary variable A) is always in the fundamental units of Hz, dB(m), or seconds.

The OM code (byte 2) can be used to determine the presently active function.

- OB(d)** Output next Band frequency, indicates the frequency of the next bandcrossing. The HP 8340A has four bandcrossing points, at 2.4 GHz, 7.0 GHz, 13.5 GHz, and 20.0 GHz. A BASIC example:

```
100 OUTPUT 719; "CW6GZ"
110 OUTPUT 719; "OB"
120 ENTER 719; A
130 PRINT "NEXT BANDCROSSING ";A/1E9;" GIGAHERTZ"
```

In this example, the HP 8340A is outputting a 6 GHz CW signal, so the next bandcrossing point is 7.0 GHz. The OB frequency is always in Hz; line 130 divides the OB value by 1×10^9 for conversion to GHz units.

- OC(3d)** Output Coupled parameters, allows the computer to read the values of the start frequency, center frequency, and sweep times (in this order) of the HP 8340A. The values are always read in the fundamental units of Hz and seconds. In BASIC:

```
100 OUTPUT 719; "FA1GZ FB19GZ STAU"
110 OUTPUT 719; "OC"
120 ENTER 719; S,C,T
130 PRINT "START FREQUENCY";S/1E9;" GHZ"
140 PRINT "CENTER FREQUENCY";C/1E9;" GHZ"
150 PRINT "SWEEP TIME";T;" SECONDS"
```

The computer would display, for this example, a start frequency of 1 GHz, a center frequency of 10 GHz, and a sweep time of 0.030 seconds.

OD Output Diagnostic values, allows the computer to read the values that result from the diagnostic functions (always in the fundamental units of Hz, dB(m), or seconds). There are three diagnostic functions that can be used with OD:

1. Oscillator frequencies diagnostic: Programming code SHM1 (keystrokes **[SHIFT] [M1]**; see figure 3-9) activates this diagnostic, which outputs the M value, N value, M/N loop frequency, and the 20/30 loop frequency. In BASIC:

```
100 OUTPUT 719; "SHM1 OD"
110 ENTER 719; M,N,R,L
120 PRINT "M VALUE "; M
130 PRINT "N VALUE "; N
140 PRINT "M/N FREQUENCY "; R; " HZ"
150 PRINT "20/30 LOOP FREQ "; L; " HZ"
```

2. Band number and YIG oscillator diagnostic: Programming code SHM2 (keystrokes **[SHIFT] [M2]**; see Figure 3-9) causes the band number and YIG oscillator frequency to be output, in this order. In BASIC:

```
100 OUTPUT 719; "SHM2 OD"
110 ENTER 719; B, Y
120 PRINT "BAND NUMBER "; B
130 PRINT "YIG OSC FREQUENCY "; Y; " HZ"
```

3. Phase lock loop (PLL) frequencies diagnostic: Programming code SHM3 (keystrokes **[SHIFT] [M3]**; see Figure 3-9) causes the PLL #2 VCO frequency and the PLL #3 upconverter frequency of the 20/30 loop to be output, in this order. In BASIC:

```
100 OUTPUT 719; "SHM3 OD"
110 ENTER 719; F2, F3
120 PRINT "PLL #2"; F2; " HZ"
130 PRINT "PLL #3"; F3; " HZ"
```

Consult Section VIII, Service, for a detailed explanation of these diagnostic functions.

OF(d) Output Fault, outputs a decimal value that can be decoded to determine which fault conditions have occurred. These fault conditions are automatically accumulated by the HP 8340A, and are only cleared by an Instrument Preset or when the fault has been output following an OF command. The outputted decimal number is interpreted at the bit level, where the bits are defined as follows:

Bit 0: Not used.
 Bit 1: Not used.
 Bit 2: N1 oscillator unlocked.
 Bit 3: N2 oscillator unlocked.
 Bit 4: YIG oscillator unlocked.
 Bit 5: HET oscillator unlocked.
 Bit 6: M/N oscillator unlocked.
 Bit 7: REF oscillator unlocked.
 Bit 8: Not used.

Bit 9: Not used.
 Bit 10: LVC - pretest of level control board failed.
 Bit 11: PEAK - peaking algorithm failed.
 Bit 12: ADC - ADC time out.
 Bit 13: KICK - YO or SYTM kick pulse time out.
 Bit 14: CAL - calibration data checksum incorrect.
 Bit 15: Not used.

If any of these fault conditions are encountered, consult Section VIII (Service) for further instructions. A BASIC example:

```

100 OUTPUT 719; "OF"
110 ENTER 719; F
120   FOR N = 0 TO 15
130   PRINT "BIT ";N;" = ";BIT(F,N)
140   NEXT N
  
```

Line 130 determines each bit of arbitrary variable F in the BIT(F,N) statement.

- OI(19a)** Output Identification, outputs the revision date of the firmware presently loaded into the HP 8340A as:

08340AREV day month year
 (2 numbers for the day, 3 letters for the month, and 2 numbers for the year)

A BASIC example:

```

10   DIM A$(19)
.
.
.
100  OUTPUT 719; "OI"
110  ENTER 719; A$
120  PRINT "FIRMWARE REVISION"; A$
  
```

- OK(d)** Output last locKed frequency, indicates the last phase locked frequency of the HP 8340A, in Hz. A BASIC example:

```

100  OUTPUT 719; "CWEK"
110  PAUSE
120  OUTPUT 719; "OK"
130  ENTER 719; F
140  PRINT "LAST FREQUENCY"; F; " HZ"
  
```

In line 100, the rotary **[KNOB]** is enabled (EK) and used to adjust the CW frequency. After completing the frequency adjustment, press **[CONTINUE]** on the computer and the last phase lock frequency (the current CW frequency in this example) is read and printed.

- OL(123b)** Output Learn data, is used in conjunction with IL (Input Learn data) to save and recall specific instrument operating configurations. OL/IL is similar to SAVE/RECALL, except: the function that was active prior to OL storage is once again active after an IL recall; and SAVE/RECALL is restricted to nine instrument configurations and uses the memory of the HP 8340A, while OL/IL uses the computer's memory and is restricted only by the size of that memory.

The learn data consists of 123 bytes of information. This information is heavily coded and densely packed for conciseness, so a byte-by-byte deciphering is not recommended (use OP to obtain information about a specific function or state). This is a typical BASIC program using OL and IL:

```

10  DIM A$(123)
.
.
.
100 OUTPUT 719; "... (programming codes) ..."
110 REM
120 REM STORE THIS INSTRUMENT STATE
130 OUTPUT 719; "OL"
140 ENTER 719 USING "#, 123A"; A$
150 REM
160 REM RETRIEVE THIS INSTRUMENT STATE
170 OUTPUT 719; "IL"&A$

```

Line 140 is a formatted I/O statement, where the # suppresses the end-of-line sequence (so valid data is not misinterpreted as EOL), and the 123A is an instruction to fill A\$ with 123 bytes of literal data. Line 170 concatenates the literal data in A\$ (which is an arbitrary variable) with the IL programming code. For additional I/O formatting information, consult the I/O Programming Manual for the specific computer being used.

OM(8b) Output Mode, outputs 8 bytes of information that completely describes the presently active functions of the HP 8340A:

Byte 1 records the last-pressed front panel key.

Byte 2 indicates the active function.

Byte 3 records the active and previously active markers.

Byte 4 indicates the marker status.

Byte 5 indicates trigger, sweep, and frequency modes.

Byte 6 indicates the status of various front panel functions.

Byte 7 indicates output power and leveling status.

Byte 8 indicates the status of the modulation and other functions.

A BASIC example:

```

10  DIM B(8)
.
.
.
100 OUTPUT 719; "OM"
110 ENTER 719 USING "#, B"; B(1), B(2), B(3), B(4), B(5), B(6), B(7), B(8)

```





```

120 FOR J = 1 TO 8
130 PRINT "BYTE "; J
140 PRINT "DECIMAL "; B(J)
150   FOR K = 0 TO 7
160     PRINT "BIT";K;"=";BIT(B(J),K)
170   NEXT K
180 PRINT
190 NEXT J
    
```

Line 110 suppresses the normal end-of-line sequence by using the “#” image specifier (this must be done in case the bit pattern of the data coincidentally duplicates the bit pattern of the EOL, which would cause a false termination), and inputs the 8 bytes of data (image specifier “B” indicates binary data). Lines 120-190 prints the bytes’ decimal and bit values. This is how to interpret the byte data:

BYTE 1 indicates the last-pressed front panel key, and the decimal value of this byte corresponds to the keys as follows:

| Decimal Value | Key | Decimal Value | Key |
|---------------|--|---------------|---------------|
| 0-9 | [0] - [9] numerical keys | 82 | [RECALL] |
| 10 | [.] | 83 | [ALT] |
| 11 | [-] minus key | 84 | not used |
| 12 | [- / BACK SPACE] used as the back space | 85 | [PULSE] |
| 13 | [▲] | 86 | [AM] |
| 14 | [▼] | 87 | [ENTRY OFF] |
| 15 | [MKR CF] | 88-96 | not used |
| 16 | [SHIFT] [MKR SWEEP] | 97 | [START FREQ] |
| 17 | [INSTR PRESET] | 98 | [STOP FREQ] |
| 18-64 | not used | 99 | [CF] |
| 65 | [CONT] | 100 | [Δ F] |
| 66 | [SINGLE] | 101 | [CW] |
| 67 | [MANUAL] | 102 | [POWER LEVEL] |
| 68 | [M1] | 103 | [SWEEP TIME] |
| 69 | [M2] | 104 | [SHIFT] |
| 70 | [M3] | 105 | [GHz / dB(m)] |
| 71 | [M4] | 106 | [MHz / sec] |
| 72 | [M5] | 107 | [KHz / msec] |
| 73 | [FREE RUN] | 108 | [Hz / AUTO] |
| 74 | [LINE] | 109 | [INT] |
| 75 | [EXT] | 110 | [XTAL] |
| 76 | [MKR SWEEP] | 111 | [METER] |
| 77 | [OFF] | 112 | [AMTD MKR] |
| 78 | [MKR Δ] | 113 | [PEAK] |
| 79 | not used | 114 | [PWR SWP] |
| 80 | [LOCAL] | 115 | [SLOPE] |
| 81 | [SAVE] | 116 | [RF] |
| | | 117-128 | not used |

| Decimal Value | Key | Decimal Value | Key |
|---|---|---------------|-----------------------|
| (Note: Although all possible shift-key combinations are listed, some of these combinations have no effect on the HP 8340A.) | | 161 | [SHIFT] [START FREQ] |
| | | 162 | [SHIFT] [STOP FREQ] |
| | | 163 | [SHIFT] [CF] |
| | | 164 | [SHIFT] [Δ F] |
| | | 165 | [SHIFT] [CW] |
| 129 | [SHIFT] [CONT] | 166 | [SHIFT] [POWER LEVEL] |
| 130 | [SHIFT] [SINGLE] | 167 | [SHIFT] [SWEEP TIME] |
| 131 | [SHIFT] [MANUAL] | 168 | [SHIFT] [SHIFT] |
| 132 | [SHIFT] [M1] | 169 | [SHIFT] [GHz / dB(m)] |
| 133 | [SHIFT] [M2] | | |
| 134 | [SHIFT] [M3] | 170 | [SHIFT] [MHz / sec] |
| 135 | [SHIFT] [M4] | 171 | [SHIFT] [KHz / msec] |
| 136 | [SHIFT] [M5] | 172 | [SHIFT] [Hz / AUTO] |
| 137 | [SHIFT] [FREE RUN] | 173 | [SHIFT] [INT] |
| 138 | [SHIFT] [LINE] | 174 | [SHIFT] [XTAL] |
| 139 | [SHIFT] [EXT] | 175 | [SHIFT] [METER] |
| 140 | not used | 176 | [SHIFT] [AMTD MKR] |
| 141 | [SHIFT] [OFF] | 177 | [SHIFT] [PEAK] |
| 142 | not used | 178 | [SHIFT] [PWR SWP] |
| 143 | not used | 179 | [SHIFT] [SLOPE] |
| 144 | [SHIFT] [LOCAL] | 180 | [SHIFT] [RF] |
| 145 | [SHIFT] [SAVE] | 181 | [SHIFT] [0] |
| 146 | [SHIFT] [RECALL] | 182 | [SHIFT] [1] |
| 147 | [SHIFT] [ALT] | 183 | [SHIFT] [2] |
| 148 | not used | 184 | [SHIFT] [3] |
| 149 | [SHIFT] [PULSE] | 185 | [SHIFT] [4] |
| | | 186 | [SHIFT] [5] |
| 150 | [SHIFT] [AM] | 187 | [SHIFT] [6] |
| 151 | [SHIFT] [ENTRY OFF] | 188 | [SHIFT] [7] |
| 152 | [SHIFT] [] | 189 | [SHIFT] [8] |
| 153 | [SHIFT] [] | 190 | [SHIFT] [9] |
| 154-160 | not used | 191 | not used |

BYTE 2 shows the presently active function. Decipher the decimal value of BYTE 2 as follows:

| Dec. Value | Active Function | Dec. Value | Active Function |
|------------|---|------------|---|
| 0 | non-numerical function (either SAVE LOCK, CLEAR LOCK, or ENTRY OFF) | 23 | HP-IB address ([SHIFT] [LOCAL]) |
| 1 | SAVE in register n | 24 | not used |
| 2 | RECALL from register n | 25 | ZOOM frequency function |
| 3 | ALternate with register n | 26 | MANUAL sweep |
| 4 | I/O read ([SHIFT] [kHz / msec]) | 27 | Frequency offset ([SHIFT] [STOP FREQ]) |
| 5 | UNLK indicators ([SHIFT] [EXT]) | 28 | frequency multiplier ([SHIFT] [START FREQ]) |
| 6 | Power LVL STEP size | 29 | RF SLOPE |
| 7 | POWER LEVEL | 30 | not used |
| 8 | SWEEP TIME | 31 | not used |
| 9 | CW RESolution | 32 | PWR SWP |
| 10 | CW frequency | 33 | not used |
| 11 | CF center frequency | 34 | Power meter leveling ([METER]) |
| 12 | Δ F delta frequency | 35 | Decoupled ATN/ALC ([SHIFT] [PWR SWP]) |
| 13 | START frequency | 36 | Attenuator control ([SHIFT] [SLOPE]) |
| 14 | STOP frequency | 37 | Bypassed ALC ([SHIFT] [METER]) |
| 15 | Marker 1 | 38 | not used |
| 16 | Marker 2 | 39 | not used |
| 17 | Marker 3 | 40 | I/O channel ([SHIFT] [GHz / dB(m)]) |
| 18 | Marker 4 | 41 | I/O subchannel ([SHIFT] [MHz / sec]) |
| 19 | Marker 5 | 42 | I/O write ([SHIFT] [kHz / msec]) |
| 20 | not used | 43 | Sweep time limit (programming code TL) |
| 21 | FREQuency STEP size | 44-245 | not used |
| 22 | Calibration constants accessed | 246 | Fault diagnostic ([SHIFT] [MANUAL]) |
| | | 247-256 | not used |

BYTE 3 shows the presently active and previously active markers. The marker information is coded in bit groups 0-2 (active marker), 3-5 (previously active marker), and 6-7 (not used); the decimal value of those bit groups is the marker number. For example:

```

BIT NUMBER  7  6  5  4  3  2  1  0
BIT PATTERN X  X  0  1  0  0  1  1
    
```

is decoded as “active marker is M3 (decimal value of bits 0-2 is 3), and previously active marker is M2 (decimal value of bits 3-5 is 2).”

BYTE 4 shows the on/off status of the markers and marker functions. If a bit is set True (=1) the marker or function is on, if the bit is False they are off. This is the bit code:

| Bit | Marker or Function |
|-----|-----------------------|
| 0 | MKR SWP |
| 1 | M1 |
| 2 | M2 |
| 3 | M3 |
| 4 | M4 |
| 5 | M5 |
| 6 | not used (always = 0) |
| 7 | MKR Δ |

BYTE 5 shows the status of the TRIGGER, SWEEP, and FREQUENCY modes. Like byte 3, the mode information is organized by bit groups, and is decoded by using the decimal value of those groups. This is the bit group organization:

| Bits | Mode Information |
|------|--|
| 0-1 | TRIGGER MODE 0 = FREE RUN 1 = LINE = EXT |
| 2-4 | SWEEP MODE 0 = CONT 1 = SINGLE 2 = MANUAL with Hz resolution (code SM) 3 = not used 4 = MANUAL with STEP resolution (code SN) |
| 5-7 | FREQUENCY MODE 0 = START/STOP 1 = CF/ Δ F 2 = CW, with sweep on 3 = CW, with sweep off |

BYTE 6 shows the status of miscellaneous modes and functions, which are ON if the appropriate bit is True (=1), or are OFF if the bit is False.

| Bit | Mode or Function |
|-----|---|
| 0 | AMTD MKR |
| 1 | not used (always = 1) |
| 2 | not used (always = 1) |
| 3 | not used (always = 0) |
| 4 | Entry enabled and rotary [KNOB] on |
| 5 | SAVE lock enabled |
| 6 | ALT mode |
| 7 | Keyboard [SHIFT] on |

BYTE 7 shows the status of the power and leveling functions. The decimal value of bit group 0-1 indicates the leveling modes, while the remaining bits indicate whether the function is on (=1) or off (=0).

| Bits | Mode or Function |
|------|--|
| 0-1 | ALC leveling modes 0 = INT 1 = XTAL 2 = METER |
| 2 | not used (always = 0) |
| 3 | PWR SWP |
| 4 | SLOPE |
| 5 | RF |
| 6 | not used |
| 7 | not used |

BYTE 8 shows the remaining front panel modes and functions, with the True bits (=1) indicating ON, and the False bits (=0) indicating OFF.

| Bits | Mode or Function |
|------|------------------------------------|
| 0 | not used (always = 0) |
| 1 | not used (always = 0) |
| 2 | not used (always = 1) |
| 3 | PULSE |
| 4 | not used |
| 5 | AM |
| 6 | PEAK |
| 7 | Penlift enabled ([SHIFT] [LINE]) |

OP(d) Output interrogated Parameter, instructs the HP 8340A to output the numerical value of any specified function, even if that function is not presently active. The code for any function that has a numerical value associated with it is appended to OP; for example, OPCF for the center frequency (but not CFOP), or OPST for the sweep time (but not STOP). The numerical value is always output in the fundamental units of Hz, dB(m), or seconds. A BASIC example:

```
100 OUTPUT 719; "OPCF"
110 ENTER 719; N
120 PRINT "CENTER FREQUENCY = "; N; " HZ"
```

In this example, N is an arbitrary variable.

OR(d) Output power level, causes the HP 8340A to output the present power level of the instrument. PLOA, OPPL and OR can be used to output power level, but there is a significant difference in the implementation of these codes by the HP 8340A: OR causes the power to be measured by the internal ADC, while PLOA and OPPL reflect the user-requested power that is shown in the ENTRY DISPLAY.

PLOA or OPPL accurately indicate the power output only when the HP 8340A is internally leveled and is not being amplitude modulated (AM) by a modulation signal containing a dc component. Under these conditions the values of PLOA, OPPL, and OR will all agree to within the tolerances of the measuring circuits (± 0.1 dB).

OR can always be used to measure power output, and must be used whenever any of these conditions exist: 1) The HP 8340A is unlevelled for any reason; 2) the instrument is being amplitude modulated by a modulation signal having a dc component; 3) the HP 8340A is being externally leveled.

A BASIC example:

```
100 OUTPUT 719; "OR"
110 ENTER 719; P
120 PRINT "POWER LEVEL = "; P; "DBM"
```

OS(2b) Output Status bytes, is used to read the two 8-bit status bytes from the HP 8340A. The first status byte concerns the cause of an SRQ (Service Request), while the second status byte concerns failures and faults, as follows:

| STATUS BYTE (#1) | | | | | | | | |
|---------------------------|--|-----------------------|---------------------------|---------------------|------------------------------|--|---|------------------------------------|
| BIT # | 7 | 6 | 5 | 4 | 3 | 2 | 1 | 0 |
| DECIMAL VALUE | 128 | 64 | 32 | 16 | 8 | 4 | 2 | 1 |
| FUNCTION | SRQ on New frequencies or Sweep Time in Effect | REQUEST SERVICE (RQS) | SRQ on HP-IB Syntax Error | SRQ on End of Sweep | SRQ on RF Settled | SRQ on Changed in Extended Status Byte | SRQ on Numeric Entry Completed (HP-IB or Front Panel) | SRQ on Any Front Panel Key Pressed |
| EXTENDED STATUS BYTE (#2) | | | | | | | | |
| BIT # | 7 | 6 | 5 | 4 | 3 | 2 | 1 | 0 |
| DECIMAL VALUE | 128 | 64 | 32 | 16 | 8 | 4 | 2 | 1 |
| FUNCTION | Fault Indicator On | RF Unlevelled | Power Failure | RF Unlocked | External Freq. Ref. Selected | Oven Cold | Over Modulation | Self Test Failed |

Status Byte 1

Bit 0: SRQ caused by a key closure on the front panel of the HP 8340A (use the OM code to determine the front panel status).

Bit 1: SRQ caused by the completion of a numeric entry (use the OA code to determine the value of the numerical entry).

Bit 2: SRQ caused by a change in the extended status byte (status byte 2) affected by the RE-coded mask (see the RE code for an explanation of this masking).

Bit 3: SRQ caused by the completion of phase locking and the settling of the RF source (use the OK code to determine the last lock frequency).

Bit 4: SRQ on end-of-sweep or mid-sweep update in NA (network analyzer code) mode.

Bit 5: SRQ caused by HP-IB syntax error.

Bit 6: SERVICE REQUEST; by IEEE-488 convention, the instrument needs service from the controller when this bit is set true.

Bit 7: SRQ caused by a change in the coupled parameters (start frequency, center frequency, and sweep time). Use the OC code to determine the new values of the coupled parameters.

Status Byte 2 (Extended Status Byte)

Bit 0: Self test failed at power on or at Instrument Preset. This bit remains latched until this status byte has been read, or until cleared by the CS or CLEAR 719 commands.

Bit 1: Excessive amplitude modulation input.

Bit 2: Oven for the reference crystal oscillator is not at operating temperature.

Bit 3: External reference frequency was selected by the rear-panel FREQUENCY STANDARD switch.

Bit 4: RF is unlocked (UNLK appears in the ENTRY DISPLAY). Use OF to determine the source of the unlocked output. This bit remains latched until this status byte has been read, or until cleared by the CS or CLEAR 719 commands.

Bit 5: AC line power interruption has occurred since the last Instrument Preset. This bit also remains latched until read or cleared.

Bit 6: RF is unlevelled (use OR to determine present power level). This bit also remains latched until read or cleared.

Bit 7: FAULT annunciator is on (seen in the ENTRY DISPLAY of the HP 8340A). Use OF to determine the cause of the fault.

A BASIC example:

```

10  REM CLEAR (RESET TO ZERO) BOTH STATUS BYTES
20  OUTPUT 719; "CS"
.
.
100 OUTPUT 719; "OS"
110 ENTER 719 USING "#,B"; S1, S2
120   S=S1
130   FOR K = 1 TO 2
140     PRINT "STATUS BYTE "; K
150     FOR N = 0 TO 7
160       PRINT "BIT ";N;" = ";BIT(S,N)
170     NEXT N
180   S=S2
190   NEXT K

```

Line 110 is a formatted I/O statement, where # suppresses the end-of-line sequence (to avoid misinterpreting valid data as an EOL sequence), and B indicates that each of the following variables (arbitrary variables S1 and S2) should be filled with one byte of information. Line 160 determines each bit of the status bytes, status byte 1 first (S = S1, N = 0 to 7) then status byte 2 (S = S2, N = 0 to 7).

Programming codes RM and RE explain how the status bytes can be masked.

RBb Remote knob, allows the rotary knob of other instruments (computers, network analyzers) to control the active function of the HP 8340A. The knob is sometimes called an RPG (rotary pulse generator) or cursor wheel in the manuals of other instruments. Here is a demonstration program for the HP 9826/9836 series of computers:

```

10  REM PRINT TO THE CRT, NOT THE LINE PRINTER
20  PRINTER IS 1

30  OUTPUT 719; "IP CW1GZ"
40  ON KNOB .075 GOSUB 60
50  GOTO 50

60  Count = KNOBX
70  PRINT "KNOB COUNT = "; Count
80  OUTPUT 719; "RB"&CHR$(Count)
90  RETURN

100 END

```

Line 30 establishes CW as the active function, with an initial value of 1.0 GHz. ON KNOB in line 40 instructs the computer to detect any rotation of the knob. The HP 9826/9836 knob generates 120 pulses per revolution; when the first pulse is detected, line 40 starts a sampling-time clock (75 milliseconds in this example) and branches to the subroutine located at line 60.

KNOBX in line 60 counts the pulses that occur in the sampling-time interval (the sampling time range is 0.01-2.55 seconds, but the sampling time must be short enough to keep the pulse count in the range of -127 to +128), and assigns the value of that count to arbitrary variable Count. Line 70 displays the pulse counts on the computer's CRT (pulse counts of ± 1 -30 are typical for this sampling time). Line 80 sends the pulse count information to the HP 8340A, where it affects the active function (CW in this example).

In line 80, the pulse count is converted from decimal to binary by the CHR\$ function, and concatenated to the RB code. One byte of numerical data can accompany RB, so the decimal value of Count has an allowable range of -127 to +128. The sampling time is arbitrary; 75 milliseconds was selected for this example because the resultant response of the computer's knob approximates the response from the HP 8340A's knob (the exact effects of the sampling time must be ascertained by experiment).

REb, RMb Request mask Extended, and Request Mask, allow masking of the extended status byte (status byte 2) and the service request status byte (status byte 1), respectively. Masking is usually done for interrupt programming, where non-critical bits of the status bytes are masked to prevent them from initiating an unimportant interrupt.

To mask a status byte, the HP 8340A must receive the RE and/or RM code that includes the numerical value of the enabled bits. The numerical value of the bits, in decimal, is:

| | | | | | | | | |
|---------|-----|----|----|----|---|---|---|---|
| BIT | 7 | 6 | 5 | 4 | 3 | 2 | 1 | 0 |
| DECIMAL | 128 | 64 | 32 | 16 | 8 | 4 | 2 | 1 |

For example, to enable bit 2 on status byte 1 while occluding the six other bits, the programming code is **"RM"&CHR\$(4)**, where the decimal value of bit 2 is converted to binary by the CHR\$ function and concatenated to the RM code.

Masked interrupt programming requires the identification and enabling of the computer's interrupt register, and the transmission of the RM/RE codes to the HP 8340A. Here is a typical BASIC example:

```

100 OUTPUT 719; "CS"
110 OUTPUT 719; "RM"&CHR$(4)
120 OUTPUT 719; "RE"&CHR$(64)
130 ENABLE INTR 7; 8
140 ON INTR 7 GOTO 500
150 OUTPUT 719; "PLEK"
.
.
.
500 PRINT "WARNING: RF UNLEVELED"

```

Line 110 enables bit 2 (only) of status byte 1, which is the bit that causes an SRQ to be sent when any of the bits in status byte 2 change. Line 120 enables bit 6 (only) of status byte 2, which detects an unlevelled RF output. Thus, an unlevelled RF is the only condition that will cause the HP 8340A to send an SRQ.

Line 130 enables the computer's interrupt register that is associated with I/O port 7, and instructs the computer to monitor bit 3 (decimal 8) for a true condition. Bit 3, in this example, is the SRQ RECEIVED bit, but the actual bit depends upon the particular computer being used (e.g., bit 2 for the HP 9826A, bit 3 for the HP-85A). Line 140 directs the program in the event of a true bit 3, which could occur if the power level is set too high (line 150 allows operator adjustment of the power level via the rotary **[KNOB]**).

Once set, several status byte bits remain latched until cleared by CS or CLEAR (or until after the status bytes are read a second time). The OS explanation describes all status byte bits.

RS Reset Sweep, causes the HP 8340A to retrace to the start frequency. If a sweep is in progress when an RS code is received, the sweep will abruptly terminate and retrace. In BASIC:

```
100 OUTPUT 719; "RS"
```

SFdt Step Frequency size, sets the size of the frequency increment that can be stepped by UP or DN (equivalent to the up/down front-panel **[STEP]** keys). The SF code is equivalent to the SHCF code, and both are equivalent to the **[SHIFT] [CF]** keystroke operation (as described in Figure 3-7).

The SF step size can be as small as 1 Hz, as large as 10 GHz, or it can be coupled to the ΔF frequency span with the AU (auto) code (the coupling is explained in Figure 3-7). A BASIC example:

```
100 OUTPUT 719; "SF 1 MZ"
110 OUTPUT 719; "CW 400 MZ"
120   FOR N = 1 TO 200
130     OUTPUT 719; "UP"
140     NEXT N
150 GOTO 110
```

This program sets the step size to 1 MHz, establishes a starting CW frequency of 400 MHz, then performs a 400-600 MHz discrete sweep.

SG Single sweep, is identical to the S2 code, and both are equivalent to the front-panel [**SINGLE**] key which is described in Figure 3-11. SG causes the HP 8340A to perform single sweeps, and is used in conjunction with the TRIGGER codes (T1, T2, and T3). If trigger code T1 ([**FREE RUN**]) is in effect, the SG code (or the TS code) is output every time a single sweep is needed. If SG is output in the middle of a sweep, the sweep will abruptly terminate and retrace. A BASIC example:

```
100 OUTPUT 719; "IP SG T1"
110 PRINT "PRESS [CONTINUE] TO START THE SWEEP"
120 PAUSE
130 OUTPUT 719; "SG"
140 GOTO 120
```

SM Sweep Manual, is identical to the S3 code, and both are equivalent to the front-panel [**MANUAL**] key which is described in Figure 3-11. SM is used by first establishing the start and stop sweep frequencies, then outputting SM to activate manual sweep mode. A BASIC example:

```
100 OUTPUT 719; "IP FA5GZ SF1MZ FB15GZ EK SM"
```

This example sets a 5 GHz start frequency, a 1 MHz frequency step size, and a 15 GHz stop frequency. The last two codes in line 100 enable the rotary [**KNOB**] and activate manual sweep mode. In addition to [**KNOB**] control of the sweep, UP and DN can be used and would have a 1 MHz step size.

There are two significant differences between manual sweep and a stepped CW sweep:

1. The sweep voltage ramp (see Figures 3-13 and 3-18, SWEEP OUTPUT) is 0-10 volts for both modes; however, in CW mode 0 volts always corresponds to 10 MHz and 10 volts always corresponds to 26.5 GHz, while in manual sweep mode 0 volts corresponds to the start frequency and 10 volts corresponds to the stop frequency. In both cases the sweep voltage at intermediate frequencies is a linear interpolation of the frequency span (i.e., a frequency half-way between the start/stop limits would have a corresponding sweep voltage of 5 volts).
2. The bandcrossing points in CW mode always occur at precisely 2.4 GHz, 7.0 GHz, 13.5 GHz, and 20.0 GHz. In manual sweep mode the bandcrossing points have 200 MHz of flexibility and could, for example, accomplish a 13.45-20.05 GHz sweep in a single band instead of the three bands required in stepped CW. The HP 8340A automatically adjusts the manual sweep bandcrossing point for optimum results.

SNdt Sweep Number, is used to establish the number of steps for a stepped sweep. The minimum number of steps is 10, while the maximum number is 1000; the frequency sweep span is divided by this SN number to determine the step increment. SN initializes the stepped sweep conditions, but the IF code or the HP-IB statement TRIGGER must be used in conjunction with SN to actually initiate each frequency step. A BASIC example:

```
100 OUTPUT 719; "FA8GZ FB12GZ SN400"
110 FOR N = 1 TO 400
120 OUTPUT 719; "IF"
130 NEXT N
```

This program causes a sweep that starts at 8 GHz and makes 400 steps (10 MHz increments) to the 12 GHz stop frequency. The IF code in line 120 initiates each of the 400 increments; alternatively, line 120 could be:

```
120 TRIGGER 719
```

SPdt Set Power step size, is identical to the SHPL code, and both are equivalent to the [SHIFT] [POWER LEVEL] key which is described in Figure 3-7.

The power step size can be as small as 0.05 dB, or as large as 50.00 dB. Once set, the power level can be incremented by the UP code or decremented by the DN code. Here is a BASIC example of a 120 dB, discrete power sweep at a 12 GHz CW frequency:

```
100 OUTPUT 719; "CW 12 GZ"
110 OUTPUT 719; "SP 0.05 DB"
120 OUTPUT 719; "PL -110 DB"
130   FOR N = 1 TO 2400
140     OUTPUT 719; "UP"
150   NEXT N
160 GOTO 120
```

The power sweep starts at -110 dBm, and increments in 2400 discrete, 0.05 dB steps to an end value of 10 dBm.

SWm SWap network analyzer channels, is used in conjunction with alternate mode and causes the foreground and background instrument states to be transposed.

Foreground refers to the present operating configuration of the HP 8340A as seen on the front panel displays and indicators, while background is the configuration that is derived from one of the SAVE/RECALL registers 1-9. When the HP 8340A is alternating between the foreground and background configurations only the foreground configuration shows on the front panel displays and indicators, even when the instrument is operating under background conditions. Hence, only the foreground configuration can be changed. SW transposes foreground and background, causing the background to show on the front panel where changes can be made.

Define the foreground configuration as state "A," and the background configuration as state "B" at the moment that alternating operation begins: At any time thereafter, SW0 causes state "A" to be the front panel state, while SW1 causes state "B" to be the front panel state.

SW does not change any of the values in the SAVE/RECALL register from which the background was derived, even if the background values are changed (when alternate mode is initiated the values in the RECALL register are transferred into the background register; after this transfer, only the background register is involved in alternating operations).

TI(b) Test HP-IB Interface, verifies correct data transmission along the HP-IB interface. The procedure involves sending a data byte to the HP 8340A, then having the HP 8340A return the same byte to the computer where the out-going and incoming data is compared. In BASIC:

```

100 FOR N = 0 TO 255
110 OUTPUT 719; "TI"&CHR$(N)
120 ENTER 719 USING "#,B"; A
130 IF A <> N THEN GOSUB 500
140 NEXT N
150 PRINT "TEST COMPLETED"
.
.
.
500 PRINT "TEST FAILED"
510 PRINT "TRANSMITTED";N;"RETURNED";A
520 PRINT
530 RETURN

```

The decimal numbers 0 through 255 cover all possible bit patterns for an 8-bit byte (thus thoroughly exercising all 8 HP-IB data lines), and these numbers are concatenated onto the TI code in line 110. The image items in line 120 specify that EOL should be suppressed (#), and that variable A (an arbitrary variable) should be filled with one byte of binary data (B). In line 130, a returned value that is less than or greater than (i.e., not equal to) the transmitted value signifies an HP-IB test failure.

TLdt Time Limit, constrains the minimum allowable sweep time. The full sweep-time range of the HP 8340A is 10 milliseconds minimum to 200 seconds maximum (although the minimum sweep time is frequency-span dependent, and cannot exceed a sweep rate of 600 MHz / 1 millisecond); TL sets a limit on the minimum sweep time, with that limit ranging from 10 milliseconds to 40 seconds. For example,

```
100 OUTPUT 719; "TL15SC"
```

changes the permissible sweep-time range to 15-200 seconds. STAU is normally used to obtain the fastest possible sweep time for a given frequency span; however, AU will not override a TL restriction.

TS Take Sweep, initiates a single, non-interruptible sweep. All HP-IB commands are deferred until that sweep has been completed. If TS is output while a sweep is in progress, that sweep will abruptly stop, retrace, and begin a new, non-interruptible sweep. The HP 8340A will resume the previous sweep operations at the completion of the TS initiated sweep. A BASIC example:

```

100 OUTPUT 719; "IP SG"
110 PRINT "PRESS [CONTINUE] TO START THE SWEEP"
120 PAUSE
130 OUTPUT 719; "TS"
140 GOTO 120

```

This completes the listing of unique HP-IB programming codes.

System Timing

It is sometimes necessary to determine the time required for a sequence of programming codes to be implemented by the HP 8340A. This can be accomplished by the computer's set-time and read-time commands:

```

100  set-time command (computer specific)
.
.
.
200  OUTPUT 719; "... (programming codes) ..."
.
.
.
300  C = read-time command (computer specific)
310  PRINT "TIME REQUIRED"; C

```

For example, the clock commands for the HP 9826/9836 computers are:

```

100  SET TIME 0
.
.
.
300  Clock = TIMEDATE MOD 86400
310  PRINT "TIME REQUIRED"; Clock

```

For the HP-80 series computers the commands are:

```

100  SETTIME 0,0
.
.
.
300  C = TIME
310  PRINT "TIME REQUIRED"; C

```

Other computers use similar commands.

HP-IB Programming Techniques for Special Applications

Although the preceding programming codes are sufficient for most applications, it is possible to program the HP 8340A at a fundamental level by directly manipulating signals on the HP-IB lines. The following material presents an introductory explanation of these specialized procedures, first by briefly explaining the HP-IB signal lines, followed by the computer codes necessary for direct control of the HP-IB lines.

HP-IB Pin-Out Description

Figure 3-25 shows a detailed view of the HP-IB connector, with a pin-out description. Notice that HP-IB has 16 dynamic, TTL-level signal lines which can be categorized into three groups: data lines, handshake lines, and system control lines. The signal level on these lines is either TTL low (a "True" condition), TTL high (a "False" condition), or floating (electrically disconnected).

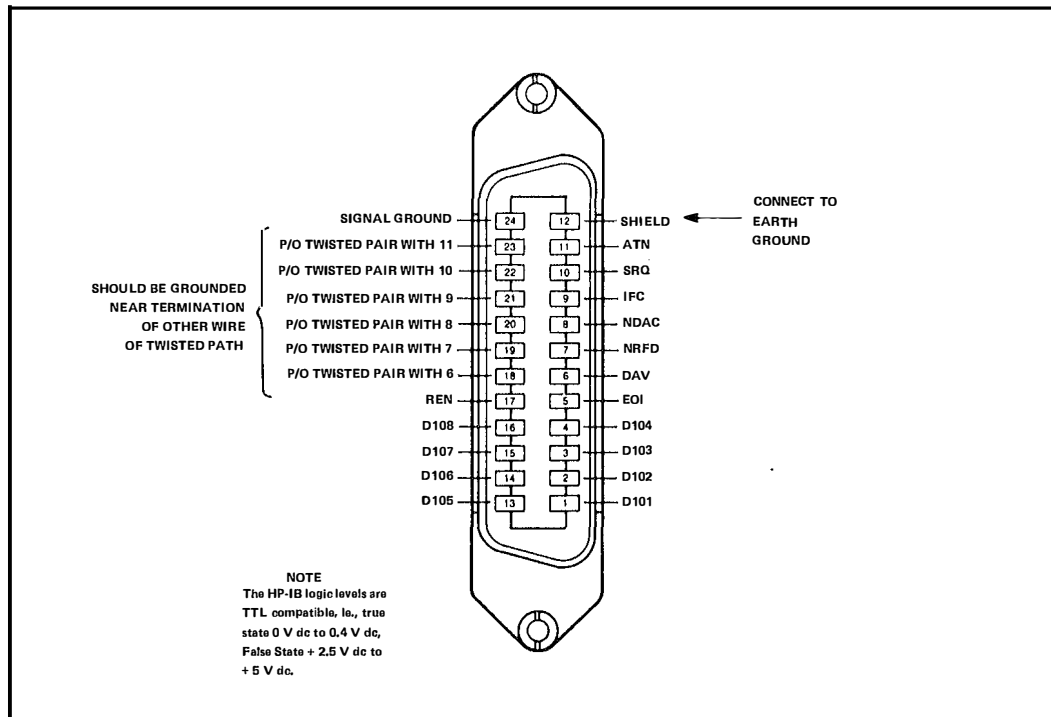

Figure 3-25. HP-IB Pin-Out

Data lines, DIO1-DIO8. These are the eight Data Input/Output lines. Data is transceived on the eight HP-IB data lines as a series of eight-bit bytes, with DIO1 being the least significant bit (LSB) and DIO8 being the most significant bit (MSB). The meaning of each byte is arbitrary, being different for each type of instrument. The rate of data transfer is controlled by the handshake sequence.

Handshake lines, DAV, NRFD, NDAC. These three lines control the data transfer process.

DAV, Data Valid, line is high (False - data not valid) or low (True - data valid) to indicate the validity of the signals on the DIO lines.

NRFD, Not Ready for Data, line indicates whether the instruments receiving data are prepared to accept that data; NRFD is either low (True - the instruments are not ready for data) or high (False - the instruments are ready for data).

NDAC, Not Data Accepted, line indicates whether the data-receiving instruments have accepted the transmitted data. The NDAC is either high (False - the data has been accepted) or low (True - the data has not been accepted).

Figure 3-26 illustrates a representative handshake timing sequence.

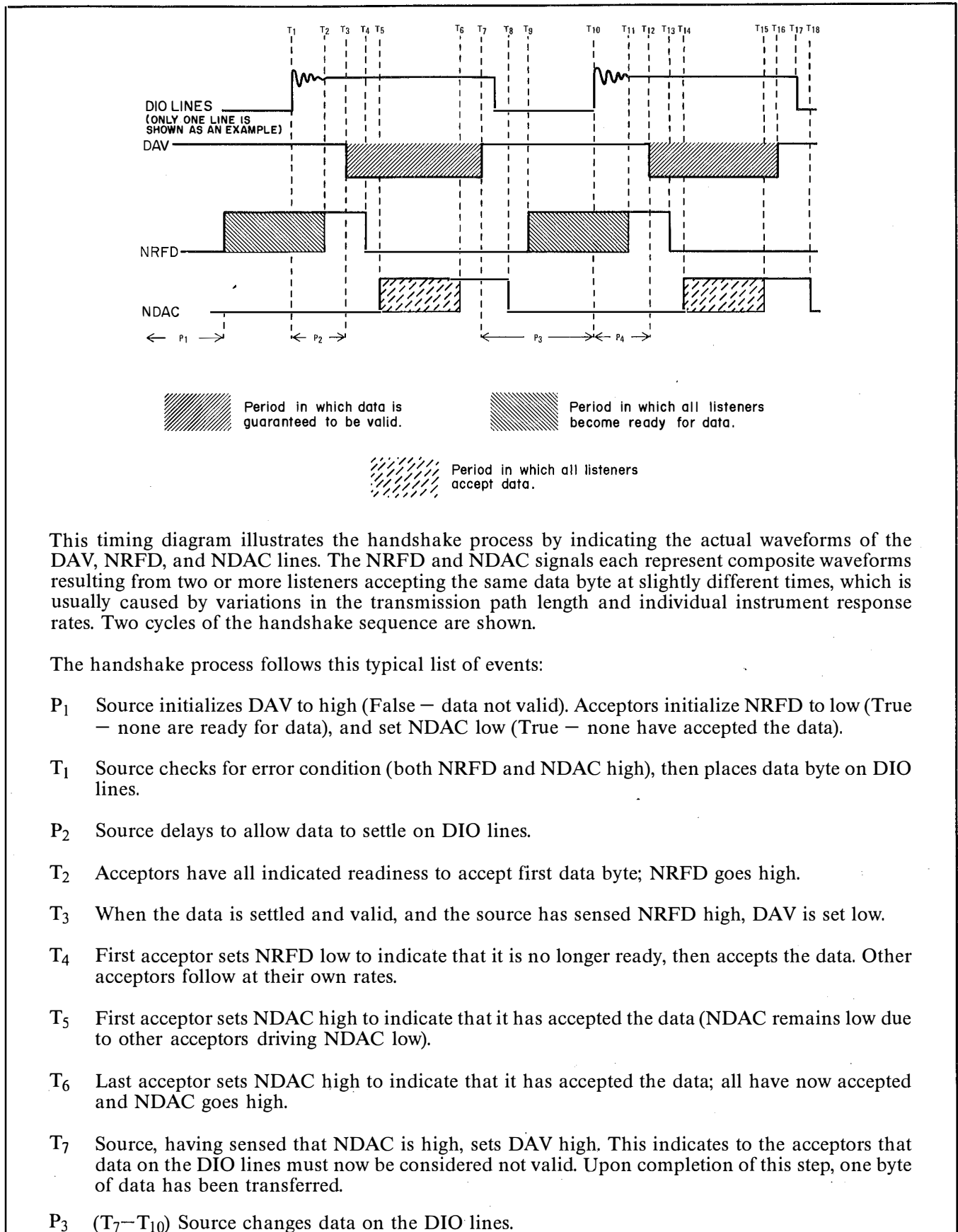

Figure 3-26. HP-IB Handshake Timing (1 of 2)

- P₄ (T₁₀–T₁₂) Source delays to allow data to settle on the DIO lines.
- T₈ Acceptors, upon sensing DAV high, set NDAC low in preparation for the next cycle. NDAC goes low as the first acceptor sets it low.
- T₉ First acceptor indicates that it is ready for the next data byte by setting NRFD high (NRFD remains low due to other acceptors driving it low).
- T₁₁ Last acceptor indicates that it is ready for the next data byte by setting NRFD high; NRFD signal line goes high.
- T₁₂ Source, upon sensing NRFD high, sets DAV low to indicate that data on the DIO lines is settled and is valid.
- T₁₃ First acceptor sets NRFD low to indicate that it is no longer ready, then accepts the data.
- T₁₄ First acceptor sets NDAC high to indicate that it has accepted the data.
- T₁₅ Last acceptor sets NDAC high to indicate that it has accepted the data (as at T₆).
- T₁₆ Source, having sensed that NDAC is high, sets DAV high (as at T₇).
- T₁₇ Source removes data byte from the DIO signal lines after setting DAV high.
- T₁₈ Acceptors, upon sensing DAV high, set NDAC low in preparation for the next cycle. All three handshake lines return to their initialized states (as at T₁ and T₂).

Figure 3-26. HP-IB Handshake Timing (2 of 2)

System control lines, ATN, IFC, SRQ, REN, EOI. The remaining five lines coordinate communications between the HP-IB LISTENERS, TALKERS, and CONTROLLERS. The system control lines are used as follows:

ATN, Attention, signals Command Mode when low (True), or Data Mode when high (False). All devices must monitor ATN at all times and respond to it within 200 nanoseconds. In Command Mode, the controller is the only talker in the network, while all other devices are listening for instructions.

When a high (False) ATN signifies Data Mode, data may be transferred along the DIO lines. The meaning of each data byte is device dependent, and selected by the instrument designer.

IFC, Interface Clear, when low (True) abruptly terminates all HP-IB communications activity: All talkers and listeners are “unaddressed,” and along with the controllers go to an inactive HP-IB state (the instruments’ local functions are not impaired). All devices must monitor IFC at all times and respond to it within 100 μ sec.

SRQ, Service Request, line is set low (True) by any instrument that needs service from the controller. An SRQ could result, for example, when an instrument is ready to transmit data upon the completion of a measurement, or from an error condition. When the controller detects an SRQ it performs a serial poll of all devices to determine which requested service, and why (polling is explained in the System Commands). The controller can mask the SRQ to prevent any inconvenient interruptions (as explained in the RE/RM programming codes). The HP 8340A lights a red SRQ annunciator in the ENTRY DISPLAY when it initiates an SRQ.

REN, Remote Enable, when low (True) enables HP-IB instruments to respond to commands from the controller or other talkers, when high (False) all devices return to local operation. The HP 8340A lights an amber REMOTE annunciator in the ENTRY DISPLAY when REN is true, and disables front panel control of the instrument (with three exceptions: the POWER switch can only be controlled locally, the [LOCAL] key re-enables front panel control unless locked-out by the controller, and the rotary [KNOB] can be re-enabled by an EK command from the controller). All devices must constantly monitor REN and respond to it within 100 μ sec.

EOI, End or Identify, is used in conjunction with ATN: When ATN is high (False) EOI goes low (True) to indicate the end of a data transmission sequence; when ATN is low (True) and EOI is low (True) a parallel poll of the HP-IB instruments is performed (the HP 8340A does not respond to parallel polling).

Typically, HP-IB data messages are sent as ASCII characters and are terminated with an ASCII "LF" (line feed, decimal 10). However, when blocks of binary information are being sent LF cannot safely be used as a terminator because the LF bit pattern could unintentionally occur in the middle of a data sequence. To prevent a false termination, the EOI line is used to signify the true end of a data sequence (alternatively, a byte-counting method that explicitly defines the number of expected data bytes can be used).

The Twelve HP-IB Messages

The HP-IB control, handshake, and data lines interact to transfer information between interconnected instruments. This information transfer process can be organized into 12 distinct categories which are, by convention, referred to as bus messages. These messages will be explained using the following HP-IB mnemonics:

ATN Attention HP-IB line TRUE, indicating Command operating mode.

$\overline{\text{ATN}}$ Attention line FALSE, indicating Data transfer mode.

CA Controller active state.

CR Carriage Return, ASCII decimal 13.

data One or more ASCII data bytes (the HP 8340A accepts lower-case ASCII characters, which it automatically upshifts).

DCL Device Clear, returns all instruments (addressed or not addressed) to an instrument-defined state; DCL is accomplished by ASCII "DC4" (decimal 20).

GET Group Execute Trigger, initiates a simultaneous instrument-defined response from all instruments; accomplished by ASCII "BS" (decimal 8).

GTL Go To Local, returns instruments to local (front panel) control; accomplished by ASCII "SOH" (decimal 1).

LA Listener active state.

LAD Listen Address of a specific Device (see LAG).

LAG Listen Address Group (listen addresses of specified instruments). An HP-IB instrument may have any unique address in the range 00-30 (decimal). The distinction between a listen address and a talk address is made in bits 5 and 6; using address 19 as an example:

| | | | | | | | | |
|--------|---|---|---|---|---|---|---|---|
| BIT | 7 | 6 | 5 | 4 | 3 | 2 | 1 | 0 |
| TALK | X | 1 | 0 | 1 | 0 | 0 | 1 | 1 |
| LISTEN | X | 0 | 1 | 1 | 0 | 0 | 1 | 1 |

The corresponding ASCII codes for the available HP-IB addresses are listed in Table 3-3.

- LF** Line Feed, ASCII decimal 10.
- LLO** Local Lockout, disables the instruments [**LOCAL**]-reset key; LLO is accomplished by ASCII "DCI" (decimal 17).
- MLA** My Listen Address (listen address of the controller).
- MTA** My Talk Address (talk address of the controller).
- PPC** Parallel Poll Configure (not used by the HP 8340A).
- PPU** Parallel Poll Unconfigure (not used by the HP 8340A).
- SC** System controller.
- SCG** Secondary command group (also abbreviated SEC).
- SDC** Selected Device Clear, causes addressed instruments to clear to an instrument-defined state; accomplished by ASCII "EOT" (decimal 4).
- SPD** Serial Poll Disable, accomplished by ASCII "EM" (decimal 25).
- SPE** Serial Poll Enable, accomplished by ASCII "CAN" (decimal 24). A serial polled instrument responds with a byte of information, with each bit corresponding to a specific instrument function.
- TA** Talker active state.
- TAD** Talk Address of a specified Device (see LAG for related information).
- TCT** Take Control, transfers active controller responsibility to another instrument; accomplished by ASCII "HT" (decimal 9).
- UNL** Unlisten, clears bus of all listeners in preparation for assigning new listeners; accomplished by ASCII "?" (decimal 63).
- UNT** Untalk, unaddresses the current talker so that no talker remains on the bus; accomplished by ASCII "_" (underscore, decimal 95).

These are the 12 bus messages (refer also to the HP-IB Command Statements that have the same names as these messages):

DATA represents the actual transfer of numerical information between instruments. The previous BASIC examples used OUTPUT and ENTER for data messages; the HP-IB bus sequence for a typical OUTPUT statement is:

ATN MTA UNL LAG $\overline{\text{ATN}}$ (ASCII data) CR LF

The HP-IB sequence for a typical ENTER statement:

ATN UNL MLA TAG $\overline{\text{ATN}}$ (ASCII data) CR LF

TRIGGER causes the listening instruments to perform an instrument-defined function, such as starting a sweep. A typical HP-IB sequence:

ATN UNL LAG GET (REN line must be True before executing GET)

CLEAR causes the listening instruments to establish an instrument-specific predefined state. The HP-IB sequence:

ATN DCL (for all bus instruments)

ATN UNL LAD SDC (for an addressed instrument)

REMOTE causes listening instruments to switch from local (front panel) control to remote program control. The HP-IB sequence:

REN ATN UNL LAG

LOCAL clears the REMOTE message and causes the listening instruments to return to local control. The HP-IB sequence:

ATN UNL LAG REN GTL

LOCAL LOCKOUT prevents an instrument over-ride of remote control. The front panel [LOCAL] key is inoperative, and only the controller (or a hard reset by the POWER switch) can restore local control. The sequence:

REN ATN LLO

CLEAR LOCKOUT/LOCAL causes all instruments on the bus to be removed from local lockout and to return to local control. The HP-IB sequence:

$\overline{\text{REN}}$

REQUIRE SERVICE (SRQ) can be sent by an instrument at any time to signify that attention is required from the controller. The HP-IB sequence:

SRQ

The SRQ line is held true until the instrument no longer needs service, or until a poll is conducted to determine the nature of the SRQ.

STATUS BYTE is an 8-bit byte of information from an addressed instrument, with each bit signifying the status of a specific instrument function. The HP-IB sequence:

ATN UNL LAD SPE $\overline{\text{ATN}}$ (data byte) CR LF ATN SPD

STATUS BIT is a parallel poll of the bus instruments. The HP 8340A does not respond to parallel polling.

PASS CONTROL transfers active control of the bus from one controller to another. The HP-IB sequence:

ATN UNL TAD TCT

ABORT terminates all bus transactions, and causes all instruments to listen for a command from the controller. The HP-IB sequence:

IFC REN $\overline{\text{ATN}}$

This completes the 12 HP-IB messages.

Table 3-3. The Standard ASCII Code (1 of 3)

| ASCII | HP-IB DIO LINES 8 7 6 5 4 3 2 1 | Octal | Decimal | Hexadecimal | HP-IB |
|-------|------------------------------------|-------|---------|-------------|-------|
| NUL | X0000000 | 000 | 000 | 00 | |
| SOH | X0000001 | 001 | 001 | 01 | GTL |
| STX | X0000010 | 002 | 002 | 02 | |
| ETX | X0000011 | 003 | 003 | 03 | |
| EOT | X0000100 | 004 | 004 | 04 | SDC |
| ENQ | X0000101 | 005 | 005 | 05 | PPC |
| ACK | X0000110 | 006 | 006 | 06 | |
| BEL | X0000111 | 007 | 007 | 07 | |
| BS | X0001000 | 010 | 008 | 08 | GET |
| HT | X0001001 | 011 | 009 | 09 | TCT |
| LF | X0001010 | 012 | 010 | 0A | |
| VT | X0001011 | 013 | 011 | 0B | |
| FF | X0001100 | 014 | 012 | 0C | |
| CR | X0001101 | 015 | 013 | 0D | |
| SO | X0001110 | 016 | 014 | 0E | |
| SI | X0001111 | 017 | 015 | 0F | |
| DLE | X0010000 | 020 | 016 | 10 | |
| DC1 | X0010001 | 021 | 017 | 11 | LLO |
| DC2 | X0010010 | 022 | 018 | 12 | |
| DC3 | X0010011 | 023 | 019 | 13 | |
| DC4 | X0010100 | 024 | 020 | 14 | DCL |
| NAK | X0010101 | 025 | 021 | 15 | PPU |
| SYN | X0010110 | 026 | 022 | 16 | |
| ETB | X0010111 | 027 | 023 | 17 | |
| CAN | X0011000 | 030 | 024 | 18 | SPE |
| EM | X0011001 | 031 | 025 | 19 | SPD |
| SUB | X0011010 | 032 | 026 | 1A | |
| ESC | X0011011 | 033 | 027 | 1B | |
| FS | X0011100 | 034 | 028 | 1C | |
| GS | X0011101 | 035 | 029 | 1D | |
| RS | X0011110 | 036 | 030 | 1E | |
| US | X0011111 | 037 | 031 | 1F | |
| space | X0100000 | 040 | 032 | 20 | LA0 |
| ! | X0100001 | 041 | 033 | 21 | LA1 |
| " | X0100010 | 042 | 034 | 22 | LA2 |
| # | X0100011 | 043 | 035 | 23 | LA3 |
| \$ | X0100100 | 044 | 036 | 24 | LA4 |
| % | X0100101 | 045 | 037 | 25 | LA5 |
| & | X0100110 | 046 | 038 | 26 | LA6 |
| ' | X0100111 | 047 | 039 | 27 | LA7 |
| (| X0101000 | 050 | 040 | 28 | LA8 |
|) | X0101001 | 051 | 041 | 29 | LA9 |
| * | X0101010 | 052 | 042 | 2A | LA10 |
| + | X0101011 | 053 | 043 | 2B | LA11 |
| , | X0101100 | 054 | 044 | 2C | LA12 |
| - | X0101101 | 055 | 045 | 2D | LA13 |
| . | X0101110 | 056 | 046 | 2E | LA14 |
| / | X0101111 | 057 | 047 | 2F | LA15 |
| 0 | X0110000 | 060 | 048 | 30 | LA16 |
| 1 | X0110001 | 061 | 049 | 31 | LA17 |

Table 3-3. The Standard ASCII Code (2 of 3)

| ASCII | HP-IB DIO LINES 8 7 6 5 4 3 2 1 | Octal | Decimal | Hexadecimal | HP-IB |
|-------|------------------------------------|-------|---------|-------------|-------|
| 2 | X0110010 | 062 | 050 | 32 | LA18 |
| 3 | X0110011 | 063 | 051 | 33 | LA19 |
| 4 | X0110100 | 064 | 052 | 34 | LA20 |
| 5 | X0110101 | 065 | 053 | 35 | LA21 |
| 6 | X0110110 | 066 | 054 | 36 | LA22 |
| 7 | X0110111 | 067 | 055 | 37 | LA23 |
| 8 | X0111000 | 070 | 056 | 38 | LA24 |
| 9 | X0111001 | 071 | 057 | 39 | LA25 |
| : | X0111010 | 072 | 058 | 3A | LA26 |
| ; | X0111011 | 073 | 059 | 3B | LA27 |
| < | X0111100 | 074 | 060 | 3C | LA28 |
| = | X0111101 | 075 | 061 | 3D | LA29 |
| > | X0111110 | 076 | 062 | 3E | LA30 |
| ? | X0111111 | 077 | 063 | 3F | UNL |
| @ | X1000000 | 100 | 064 | 40 | TA0 |
| A | X1000001 | 101 | 065 | 41 | TA1 |
| B | X1000010 | 102 | 066 | 42 | TA2 |
| C | X1000011 | 103 | 067 | 43 | TA3 |
| D | X1000100 | 104 | 068 | 44 | TA4 |
| E | X1000101 | 105 | 069 | 45 | TA5 |
| F | X1000110 | 106 | 070 | 46 | TA6 |
| G | X1000111 | 107 | 071 | 47 | TA7 |
| H | X1001000 | 110 | 072 | 48 | TA8 |
| I | X1001001 | 111 | 073 | 49 | TA9 |
| J | X1001010 | 112 | 074 | 4A | TA10 |
| K | X1001011 | 113 | 075 | 4B | TA11 |
| L | X1001100 | 114 | 076 | 4C | TA12 |
| M | X1001101 | 115 | 077 | 4D | TA13 |
| N | X1001110 | 116 | 078 | 4E | TA14 |
| O | X1001111 | 117 | 079 | 4F | TA15 |
| P | X1010000 | 120 | 080 | 50 | TA16 |
| Q | X1010001 | 121 | 081 | 51 | TA17 |
| R | X1010010 | 122 | 082 | 52 | TA18 |
| S | X1010011 | 123 | 083 | 53 | TA19 |
| T | X1010100 | 124 | 084 | 54 | TA20 |
| U | X1010101 | 125 | 085 | 55 | TA21 |
| V | X1010110 | 126 | 086 | 56 | TA22 |
| W | X1010111 | 127 | 087 | 57 | TA23 |
| X | X1011000 | 130 | 088 | 58 | TA24 |
| Y | X1011001 | 131 | 089 | 59 | TA25 |
| Z | X1011010 | 132 | 090 | 5A | TA26 |
| [| X1011011 | 133 | 091 | 5B | TA27 |
| \ | X1011100 | 134 | 092 | 5C | TA28 |
|] | X1011101 | 135 | 093 | 5D | TA29 |
| ^ | X1011110 | 136 | 094 | 5E | TA30 |
| _ | X1011111 | 137 | 095 | 5F | UNT |
| ' | X1100000 | 140 | 096 | 60 | SC0 |
| a | X1100001 | 141 | 097 | 61 | SC1 |
| b | X1100010 | 142 | 098 | 62 | SC2 |
| c | X1100011 | 143 | 099 | 63 | SC3 |

Table 3-3. The Standard ASCII Code (3 of 3)

| ASCII | HP-IB DID LINES 8 7 6 5 4 3 2 1 | Octal | Decimal | Hexadecimal | HP-IB |
|-------|------------------------------------|-------|---------|-------------|-------|
| d | X1100100 | 144 | 100 | 64 | SC4 |
| e | X1100101 | 145 | 101 | 65 | SC5 |
| f | X1100110 | 146 | 102 | 66 | SC6 |
| g | X1100111 | 147 | 103 | 67 | SC7 |
| h | X1101000 | 150 | 104 | 68 | SC8 |
| i | X1101001 | 151 | 105 | 69 | SC9 |
| j | X1101010 | 152 | 106 | 6A | SC10 |
| k | X1101011 | 153 | 107 | 6B | SC11 |
| l | X1101100 | 154 | 108 | 6C | SC12 |
| m | X1101101 | 155 | 109 | 6D | SC13 |
| n | X1101110 | 156 | 110 | 6E | SC14 |
| o | X1101111 | 157 | 111 | 6F | SC15 |
| p | X1110000 | 160 | 112 | 70 | SC16 |
| q | X1110001 | 161 | 113 | 71 | SC17 |
| r | X1110010 | 162 | 114 | 72 | SC18 |
| s | X1110011 | 163 | 115 | 73 | SC19 |
| t | X1110100 | 164 | 116 | 74 | SC20 |
| u | X1110101 | 165 | 117 | 75 | SC21 |
| v | X1110110 | 166 | 118 | 76 | SC22 |
| w | X1110111 | 167 | 119 | 77 | SC23 |
| x | X1111000 | 170 | 120 | 78 | SC24 |
| y | X1111001 | 171 | 121 | 79 | SC25 |
| z | X1111010 | 172 | 122 | 7A | SC26 |
| { | X1111011 | 173 | 123 | 7B | SC27 |
| | X1111100 | 174 | 124 | 7C | SC28 |
| } | X1111101 | 175 | 125 | 7D | SC29 |
| ~ | X1111110 | 176 | 126 | 7E | SC30 |
| DEL | X1111111 | 177 | 127 | 7F | SC31 |

ASCII Abbreviations

| | | |
|--------------------------------|---------------------------------|-----------------------------------|
| NUL null | VT vertical tab | SYN synchronous idle |
| SOH start of heading | FF form feed | ETB end transmission block |
| STX start text | CR carriage return | CAN cancel |
| ETX end text | SO shift out | EM end of medium |
| EOT end of transmission | SI shift in | SUB substitute |
| ENQ enquiry | DLE data link escape | ESC escape |
| ACK acknowledge | DC1 direct control 1 | FS form separator |
| BEL bell | DC2 direct control 2 | GS group separator |
| BS backspace | DC3 direct control 3 | RS record separator |
| HT horizontal tab | DC4 direct control 4 | US unit separator |
| LF line feed | NAK negative acknowledge | DEL delete |

HP-IB Abbreviations

| | | |
|------------------------------------|--------------------------------------|---------------------------------|
| GTL go to local | LLO local lockout | LA0-30 listen address |
| SDC selected device clear | DCL device clear | UNL unlisten |
| PPC parallel poll configure | PPU parallel poll unconfigure | TA0-30 talk address |
| GET group execute trigger | SPE serial poll enable | UNT untalk |
| TCT take control | SPD serial poll disable | SC0-31 secondary command |

Computer Access of HP-IB Lines

The I/O Programming Guide for the specific computer being used must be consulted for detailed information about direct access to the HP-IB lines; however, the intent of the following discussion is to introduce the fundamental procedures involved in this type of programming. After this introduction, the programmer will know what specific information to look for in the computer's I/O Programming Guide.

Sending HP-IB Messages

The BASIC statement used to transmit information directly to the HP-IB lines is the SEND statement, which has this syntax:

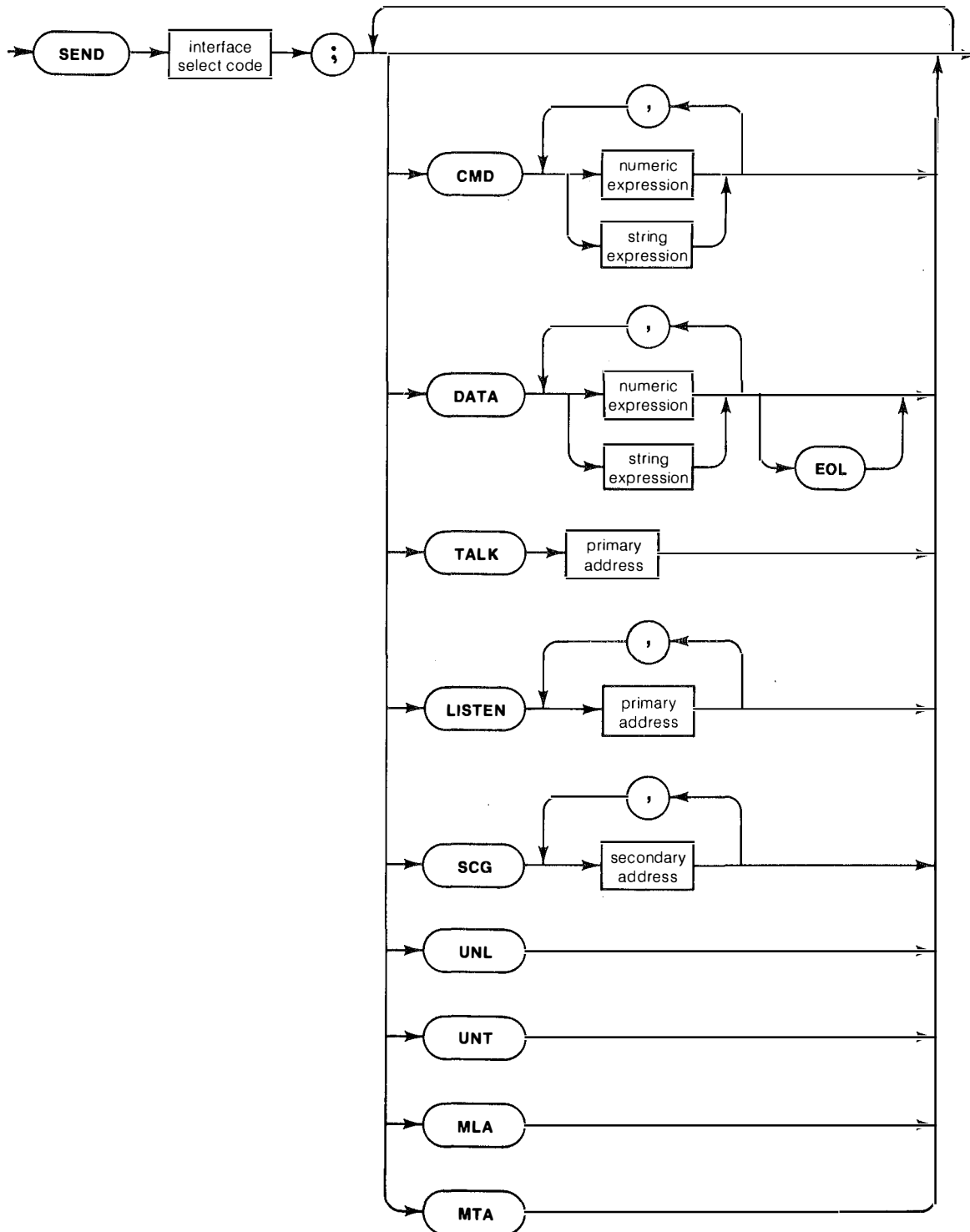

The secondary command DATA sets the ATN line False; all other secondary commands (CMD, TALK, LISTEN, UNL, UNT, MLA, and MTA) set ATN True. Information accompanying the SEND statement can be either ASCII encoded characters that correspond to the HP-IB functions (see Table 3-3), or computer-recognized mnemonics. For example, to read the status bytes from the HP 8340A, the HP-IB sequence is:

UNL MLA (the computer's) TAD (HP 8340A's) SPE (data bytes) SPD UNT

This sequence is accomplished, in BASIC, by using either computer-recognized mnemonics:

```
100 SEND 7; UNL MLA TALK 19 CMD 24
110 ENTER 7 USING "#, B"; S
120 SEND 7; CMD 25 UNT
```

where CMD 24 is SPE, and CMD 25 is SPD; or the same sequence can be accomplished using ASCII encoded HP-IB information:

```
100 SEND 7; CMD "?5S"&CHR$(24)
110 ENTER 7 USING "#, B"; S
120 SEND 7; CMD CHR$(25)&"_"
```

In line 100, ? is the ASCII code for UNL, 5 is a representative MLA, and S is TA19. In line 120, "_" (underscore) is the ASCII code for UNT. In both examples the ATN line is set True or False by the computer, depending on the context of the mnemonics, and does not require any specific commands.

(This is an illustrative example only; status bytes can be more easily read using a simple OUTPUT "OS" statement.)

Reading HP-IB Messages

The HP-IB lines are read by examining the computer's status registers, using the STATUS statement. The STATUS statement has this syntax:

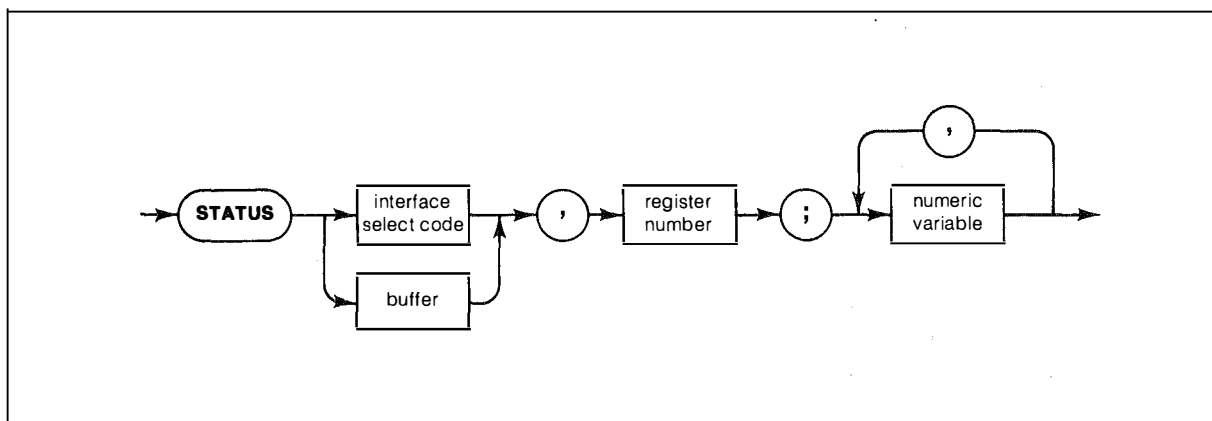

The function assignment of each status register is computer specific. Figure 3-27 shows representative status register assignments, from the HP 9826 and HP-85A computers.

HP 9826/9836 Status Register 7

Most Significant Bit

| | | | | | | | |
|--------------------|-------------------|------------------|------------------|------------------|------------------|----------------|----------------|
| Bit 15 | Bit 14 | Bit 13 | Bit 12 | Bit 11 | Bit 10 | Bit 9 | Bit 8 |
| ATN True | DAV True | NDAC* True | NRFD* True | EOI True | SRQ** True | IFC True | REN True |
| Value = -32 768 | Value = 16 384 | Value = 8 192 | Value = 4 096 | Value = 2 048 | Value = 1 024 | Value = 512 | Value = 256 |

Least Significant Bit

| | | | | | | | |
|-------------|------------|------------|------------|-----------|-----------|-----------|-----------|
| Bit 7 | Bit 6 | Bit 5 | Bit 4 | Bit 3 | Bit 2 | Bit 1 | Bit 0 |
| DIO8 | DIO7 | DIO6 | DIO5 | DIO4 | DIO3 | DIO2 | DIO1 |
| Value = 128 | Value = 64 | Value = 32 | Value = 16 | Value = 8 | Value = 4 | Value = 2 | Value = 1 |

* Only if addressed to TALK, else not valid.

** Only if Active Controller, else not valid.

HP 85A HP-IB Status Registers

| Status Register Number | Bit Number | | | | | | | | Default Value | Register Function |
|------------------------|------------|------|------|------|------|--------------|------|------|----------------|----------------------------------|
| | 7 | 6 | 5 | 4 | 3 | 2 | 1 | 0 | | |
| SR0 | 0 | 0 | 0 | 0 | 0 | 0 | 0 | 1 | 1 | Interface Identification |
| SR1 | IFC | LA | CA | TA | SRQ | DCL or SDC | GET | SCG | 0 | Interrupt Cause |
| SR2 | 0 | REN | SRQ | ATN | EOI | DAV | NDAC | NRFD | 64 | HP-IB Control Lines |
| SR3 | DIO8 | DIO7 | DIO6 | DIO5 | DIO4 | DIO3 | DIO2 | DIO1 | Not Applicable | HP-IB Data Lines |
| SR4 | 0 | 0 | SC | A4 | A3 | A2 | A1 | A0 | 53 | HP-IB Address/ System Controller |
| SR5 | SC | LA | CA | TA | SPE | Parity Error | REN | LLO | 160 | State Register |
| SR6 | 0 | 0 | 0 | SC5 | SC4 | SC3 | SC2 | SC1 | 0 | Secondary Commands |

Figure 3-27. Representative Status Registers

Here is a BASIC example of reading the status registers:

```

100 FOR N = 0 TO 6
110 STATUS 7,N; S
120 PRINT "STATUS REGISTER"; N
130 PRINT
140   FOR J = 0 TO 7
150     PRINT "BIT";J;"=";BIT(S,J)
160   NEXT J
170 PRINT
180 NEXT N
    
```

Direct Writing to the HP-IB Lines

The final programming technique covered in this manual involves direct writing to the HP-IB data, handshake, and control lines. This is very advanced programming, and should be attempted only by experienced programmers who are thoroughly familiar with the HP 8340A and HP-IB protocols.

CAUTION

Bus malfunctions or damage can result from errant applications of direct writing to HP-IB lines.

Direct writing to the HP-IB lines is accomplished by the CONTROL statement, which has this syntax:

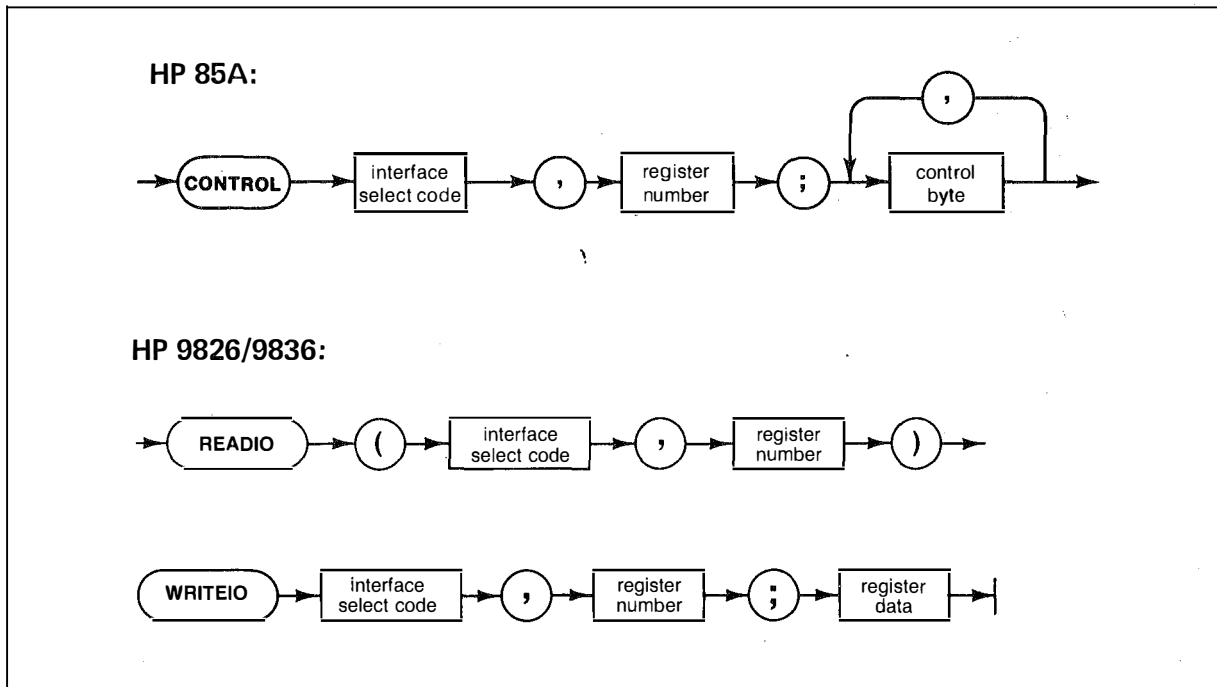

The CONTROL statement (ASSERT, READIO/WRITEIO are related statements used by some computers) is used to send information to the computer's control registers, which have bit patterns that correspond to the HP-IB lines. The bit pattern of the control registers is computer specific; Figure 3-28 shows representative control registers from the HP 9826 and HP-85A computers.

HP 85A HP-IB Control Registers

| Register Number | Bit Number | | | | | | | | Default Value | Register Function |
|-----------------|------------|------|------|------|------|------------|------------|-------------|----------------|---------------------|
| | 7 | 6 | 5 | 4 | 3 | 2 | 1 | 0 | | |
| CR0 | X | X | X | X | Odd | Even | Always One | Always Zero | 0 | Parity Control |
| CR1 | IFC | LA | CA | TA | SRQ | DCL or SDC | GET | SCG | 0 | Interrupt Mask |
| CR2 | X | REN | SRQ | ATN | EOI | DAV | NDAC | NRFD | Not Applicable | HP-IB Control Lines |
| CR3 | DI08 | DI07 | DI06 | DI05 | DI04 | DI03 | DI02 | DI01 | Not Applicable | HP-IB Data Lines |

HP 9826/9836 HP-IB READIO Register 23

Control-Line Status

| Most Significant Bit | | | | | | Least Significant Bit | |
|----------------------|------------|------------|------------|-----------|------------|-----------------------|-----------|
| Bit 7 | Bit 6 | Bit 5 | Bit 4 | Bit 3 | Bit 2 | Bit 1 | Bit 0 |
| ATN True | DAV True | NDAC* True | NRFD* True | EOI True | SRQ** True | IFC True | REN True |
| Value = 128 | Value = 64 | Value = 32 | Value = 16 | Value = 8 | Value = 4 | Value = 2 | Value = 1 |

*Only if addressed to TALK, else not valid.

**Only if Active Controller, else not valid.

HP 9826/9836 HP-IB READIO Register 31

Bus Data Lines

| Most Significant Bit | | | | | | Least Significant Bit | |
|----------------------|------------|------------|------------|-----------|-----------|-----------------------|-----------|
| Bit 7 | Bit 6 | Bit 5 | Bit 4 | Bit 3 | Bit 2 | Bit 1 | Bit 0 |
| DIO8 | DIO7 | DIO6 | DIO5 | DIO4 | DIO3 | DIO2 | DIO1 |
| Value = 128 | Value = 64 | Value = 32 | Value = 16 | Value = 8 | Value = 4 | Value = 2 | Value = 1 |

HP 9826/9836 HP-IB WRITE10 Register 31

Data-Out Register

| Most Significant Bit | | | | | | Least Significant Bit | |
|----------------------|------------|------------|------------|-----------|-----------|-----------------------|-----------|
| Bit 7 | Bit 6 | Bit 5 | Bit 4 | Bit 3 | Bit 2 | Bit 1 | Bit 0 |
| DIO8 | DIO7 | DIO6 | DIO5 | DIO4 | DIO3 | DIO2 | DIO1 |
| Value = 128 | Value = 64 | Value = 32 | Value = 16 | Value = 8 | Value = 4 | Value = 2 | Value = 1 |

Figure 3-28. Representative Control Registers

The bits in the control registers are set using this statement:

CONTROL 7, (register number); (decimal value of True bits)

To set the bits (and the corresponding HP-IB lines) True (=1), use their corresponding decimal values:

| | | | | | | | | |
|---------|-----|----|----|----|---|---|---|---|
| BIT | 7 | 6 | 5 | 4 | 3 | 2 | 1 | 0 |
| DECIMAL | 128 | 64 | 32 | 16 | 8 | 4 | 2 | 1 |

For example,

100 CONTROL 7,2; 16

sets bit 4 (decimal 16) of control register 2 True, while all other bits in that register are set False. As another example,

100 CONTROL 7,3; 63

sets bits 0-5 True (decimal $1+2+4+8+16+32 = 63$) and bits 6-7 False.

This completes the HP-IB programming information.

USING THE 8340 POWER CONTROL AND MODULATION SYSTEMS.

The preceding explanations of the power control and modulation functions are sufficient for the majority of applications; however, to extract the utmost performance from this instrument the following special information might be helpful.

INTERNAL LEVELING

The RF Output power is controlled by the automatic level control (ALC) circuit, otherwise referred to as the leveling loop. Figure 3-29 shows a simplified diagram of this system. The leveling loop is a feedback control system, in which the output power is measured and compared to the desired level. If the two are not equal the loop changes the output until they are equal.

The two inputs labeled "ALC INPUTS" convey the desired power level. One of these is a voltage derived from the power value shown in the ENTRY DISPLAY. In the absence of modulation this voltage is used to set the output power level. The amplitude modulation (AM) input causes the output to increase or decrease relative to this level. (The pulse modulation input is essentially on ON/OFF switch, not an ALC input.)

The RF power level from the level control circuits is referred to as the "ALC level," and is measured by a crystal detector. The DC output from this detector is fed back to the level control circuits for comparison with the ALC inputs. Since crystal detectors lose sensitivity at low power levels, the detector provides an accurate power indication for ALC levels down to -10 dBm, and is acceptable (± 1 dB) down to -20 dBm. The maximum amount of power available from the level control circuits varies with RF frequency, from $+1$ dBm specified at 26.5 GHz to typically $+21$ dBm at 4.5 GHz; therefore, the level control circuits can provide continuous control of ALC levels over a maximum span of approximately -20 dBm to $+20$ dBm.

Coupled Mode

Since many applications require power levels less than -20 dBm, a step attenuator is provided that has a range of 0 to -90 dB in 10 dB steps. Thus, power levels down to -110 dBm is achieved when the attenuator and ALC work in conjunction. Because of the attenuator, the ALC will normally be used over only a portion of its 40 dB range: Since accuracy suffers below -10 dBm and at some frequencies only $+1$ dBm is available, the ALC is normally set between -10 dBm and 0 dBm. The restricted range of the ALC reduces the primary power span to 0 to -100 dBm. To get power less than -100 dBm, the attenuator is left at -90 dB, and the ALC used from -10 to -20 dBm; however, the ALC accuracy and noise performance is degraded at this level, and is the reason that some specifications apply only down to -100 dBm. At frequencies where power levels above 0 dBm are desired, the attenuator is left at 0 dB and the ALC used from 0 to $+20$ dBm (or whatever power is available at the RF frequency in use). The proper combination of ALC and attenuator is decided by the internal microprocessor: the user need only set the desired power in the ENTRY DISPLAY via the [POWER LEVEL] key.

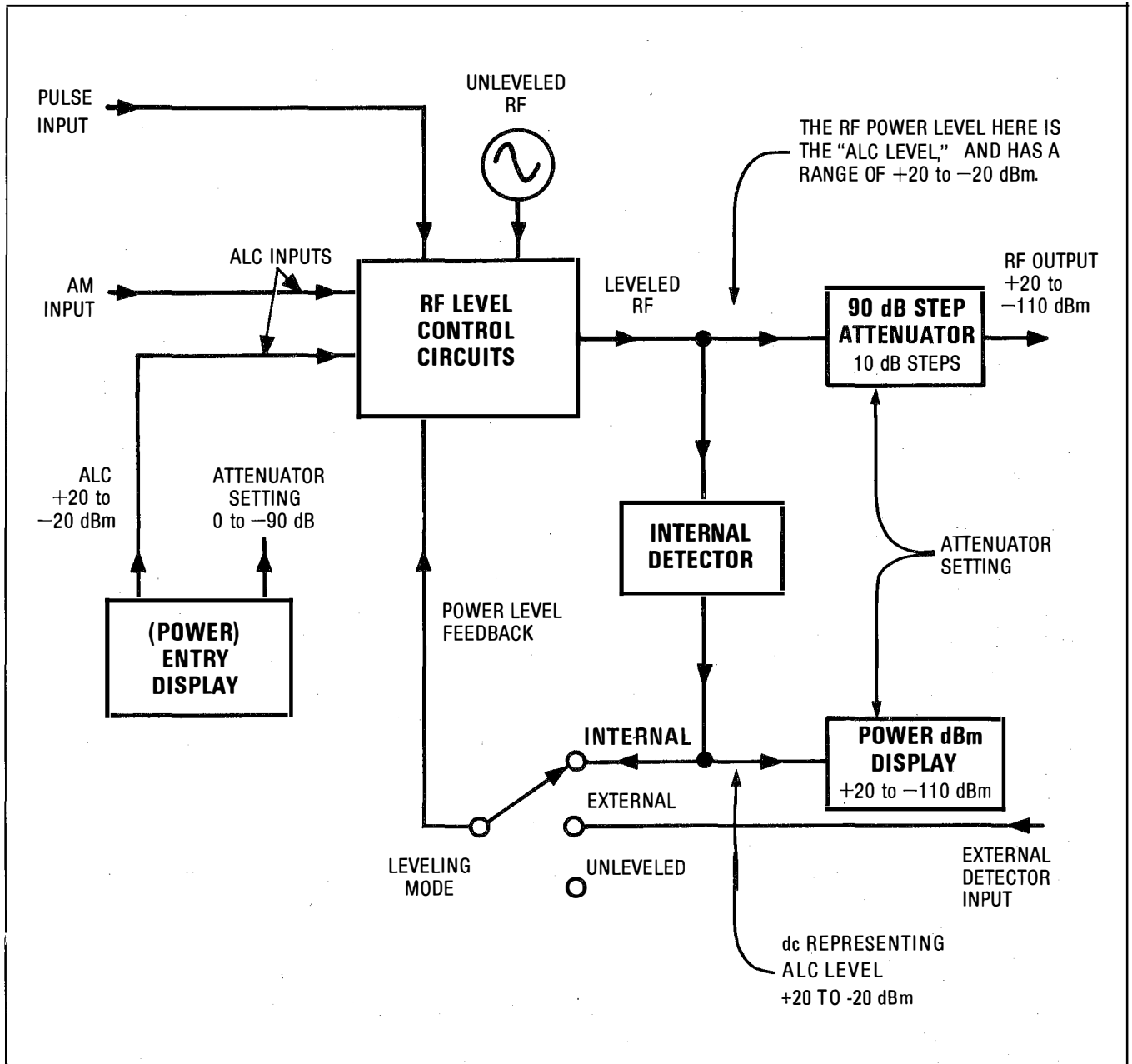

Figure 3-29. ALC Loop Block Diagram

POWER dBm Display

If the requested power is greater than can be provided, the level control loop will provide maximum available power and light the UNLEVELED annunciator. When unlevelled, the output power does not equal the value shown in the ENTRY DISPLAY. The internal detector is monitoring the actual power, however, and its output voltage controls the POWER dBm display. The detector voltage is interpreted to give ALC level, and the attenuator setting is subtracted to yield actual output power, even when unlevelled.

The AM input is DC coupled, and a DC input will change the output power. This change does not appear in the ENTRY DISPLAY, but the POWER dBm display accurately indicates the real output.

When internally leveled, UNLEVELED annunciator off, and AM off the POWER dBm display simply repeats the value shown in the ENTRY DISPLAY. When externally leveled, or the UNLEVELED annunciator is on, or AM modulation is in effect the POWER dBm display indicates the ALC level and reflects the true output power. This might not agree with the ENTRY DISPLAY value, which shows the desired level in the absence of modulation.

The above should be understood when using power sweep. When the POWER dBm display is repeating the ENTRY DISPLAY, it indicates start power. If the POWER dBm display is indicating ALC level, it shows the average power over the sweep. (The circuit is heavily filtered above 5 Hz.) Since the start and stop dwell times are unequal, this average reading has little meaning.

In a variety of situations it is possible to drive the ALC level below -20 dBm, such as putting DC into the AM input, or when externally leveled. Since the internal detector is inaccurate at these levels, the POWER dBm display would be very misleading. For that reason, and as a warning, the POWER dBm display blanks at ALC levels below -22.0 dBm. This may occur at an output power of -22 dBm, -32 dBm, -42 dBm, etc., depending on the attenuator setting.

Decoupled Mode

In some applications it is advantageous to control the ALC and attenuator separately, achieving combinations of settings which are not available in the coupled mode. Press **[SHIFT] [PWR SWP]** to activate decoupled mode, which causes "ATTN: _____ dB, ALC: _____ . _____ dBm" to show in the ENTRY DISPLAY. The ALC setting is entered via keypad or **[KNOB]**, while the attenuator is incremented with the **[STEP]** keys. As before, the POWER dBm display indicates the true, composite output power. (Caution: If an entry is made in decoupled mode, and subsequently **[POWER LEVEL]** is pressed, the HP 8340A reverts to coupled mode. It will set itself to the same power level, but the attenuator and ALC settings may be different.)

One use of decoupled operation is power sweep, where the output power linearly tracks the sweep voltage ramp. The HP 8340A can generate power sweeps of up to 40 dB, depending on frequency. The power at the start of the sweep is set via **[POWER LEVEL]** (coupled operation) or **[SHIFT] [PWR SWP]** (decoupled operation), and the sweep range (the amount the power increases during the sweep) is entered by pressing **[PWR SWP]** followed by the desired dB sweep value. If the sweep range entered exceeds the ALC range (stop power greater than maximum available power) the UNLEVELED annunciator will light at the end of sweep. No warning is given at the time of entry. If the start power is entered via the **[POWER LEVEL]** key, the ALC is set no lower than -10 dBm, limiting available power sweep range to 30 dB at 4.5 GHz, or 11 dB at 26.5 GHz. Using decoupled mode and setting the ALC to -20 dBm gives an additional 10 dB of sweep range (although at -20 dBm, start power uncertainty is degraded by ± 1 dB).

Decoupled mode is also useful when working with mixers. Figure 3-30A shows a hypothetical setup where an HP 8340A is providing the small signal to a mixer. The HP 8340A output is -8 dBm, which in coupled mode results in ALC = -8 dBm, ATTN = 0 dB. The mixer is driven with an LO of $+10$ dBm, and has LO to RF isolation of 15 dB. The resulting LO feedthrough of -5 dBm enters the HP 8340A's OUTPUT port, goes through the attenuator with no loss, and arrives at the internal detector. Depending on frequency, it is possible for most of this energy to enter the detector. Since the detector responds to its total input power regardless of frequency, this excess energy causes the leveling circuit to reduce its output. In this example the reverse power is actually larger than the ALC level, which may result in the HP 8340A output being shut off.

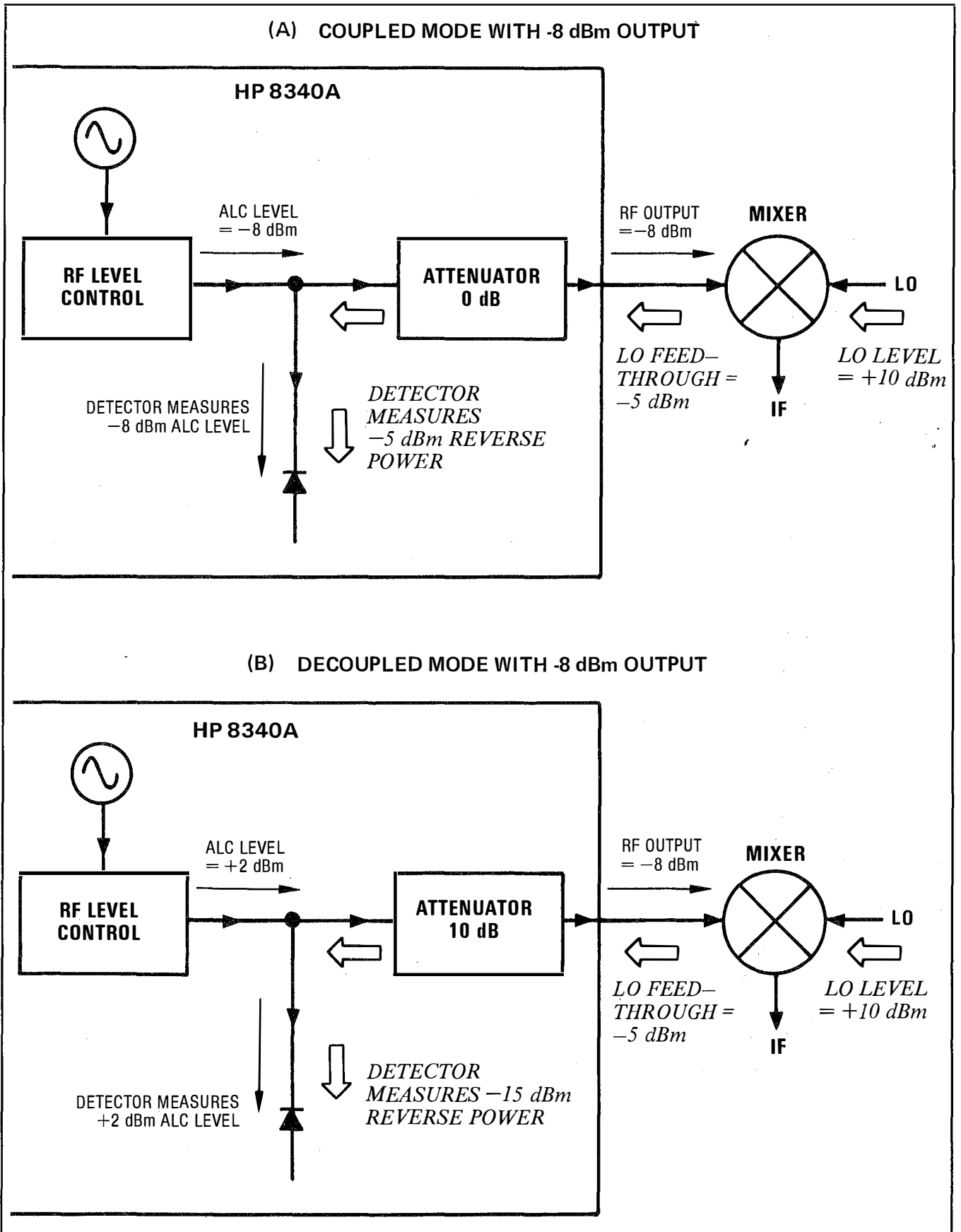

Figure 3-30. Reverse Power Effects

Figure 3-30B shows the same setup, with decoupled mode used to give a -8 dBm output: $ALC = +2$ dBm, $ATTN = -10$ dB. The ALC is 10 dB higher, and the attenuator reduces the LO feedthrough by 10 dB. Thus the detector sees $+2$ dBm desired signal versus a possible -15 dBm undesired one. This 17 dB difference results in a maximum 0.1 dB shift in the HP 8340A's output level.

Reverse power is a problem with spectrum analyzers that do not have preselection capability. Some analyzers have as much as $+5$ dBm LO feedthrough coming out of their RF input, at some frequencies. The effects of reverse power are less in the heterodyne band (.01 to 2.3 GHz) where the power amplifier provides some broadband matching. Similarly, from 2.3 to 26.5 GHz, reverse power that is within 10 MHz of the HP 8340A's frequency may be partially absorbed by the YIG filter. If the frequency difference is small enough to be within the leveling loop bandwidth (typically 10 kHz CW, 200 kHz sweep or AM), the effect of reverse power is amplitude modulation of the HP 8340A's output. The AM rate equals the difference in RF frequencies. Reverse power problems may be treated by using the unlevelled mode, as described in that section.

When using decoupled mode to set low ALC levels, some caution is necessary. At $ALC = -20$ dBm, the amplitude accuracy degrades by ± 1 dB. This results from temperature induced drift in the detection circuitry. Some spurious signals, such as ac power line related sidebands, are worse at -20 dBm and may exceed specifications (which do not apply at $ALC = -20$ dBm). Despite its level uncertainty, the output power at $ALC = -20$ dBm is more stable than a normal power meter. In checking the output, care must be taken to zero the meter with the HP 8340A's RF turned off. Pressing the "sensor zero" button on a power meter does not assure that it is zeroed, since the display on some meters is blank for inputs below -30 dBm when in the "dBm" mode. Selecting the "WATT" mode keeps the display alive, and the user can then see if the meter is really zeroed (press the zero button several times if necessary).

When the HP 8340A's heterodyne band (.01 to 2.3 GHz) is in use, approximately -30 dBm of broadband noise is generated along with the desired signal. If the desired signal is -20 dBm and the result measured on a power meter, the reading will be about 0.5 dB high. To accurately measure the signal, the power meter must be zeroed in the presence of the noise: Connect the power meter, then press **[RF]** to shut off any RF output; although the RF is off, the noise is still present and the power meter can now be zeroed. When going to frequencies above 2.3 GHz, the meter must be re-zeroed. The broadband noise is attenuated by the step attenuator, along with the desired signal. Noise makes a 0.05 dB contribution at $ALC = -10$ dBm.

UNLEVELED MODE

The HP 8340A has a power control mode in which the leveling feedback loop is opened. The ALC inputs are used to directly control the RF modulator. Pressing **[SHIFT] [METER]** activates this mode. The annunciators on the leveling mode keys are extinguished, the UNLEVELED annunciator is lighted, and the ENTRY DISPLAY shows: $ATTN: \underline{\quad} \text{ dB}$, $MOD: \underline{\quad} . \underline{\quad} \text{ dB}$. As with the decoupled mode, the attenuator is set via the **[STEP]** keys, and the modulator entry is made with keypad or **[KNOB]**. The entry range is 0 to -100 dB. The modulator entry is an approximately calibrated relative indication, because the modulator's gain and maximum output change with frequency. See Figure 3-31.

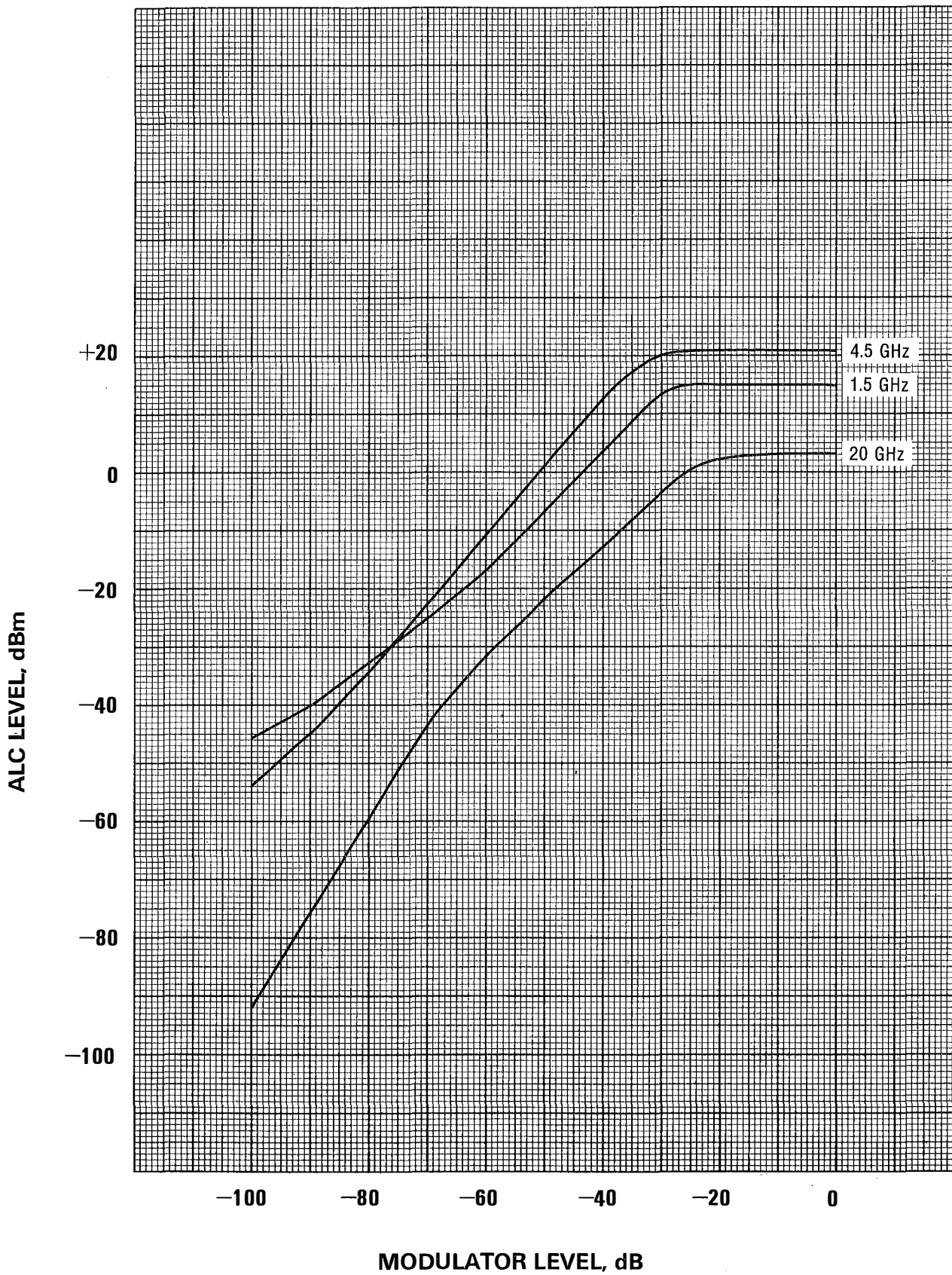

Figure 3-31. Typical Unleveled Modulation Response

AM works in this mode with unspecified distortion. Pulse modulation works. Power sweep works with linearity as depicted in Figure 3-31. The POWER dBm display still indicates actual output power. As with other leveling modes, it indicates the sum of "ALC level" and attenuation, with useful accuracy down to ALC levels of -20 dBm. It blanks at ALC levels below -22 dBm. Sweeps will, of course, be unlevelled. When in the unlevelled mode, there is no feedback stabilization of power, and its stability versus time and temperature is unspecified.

This mode is useful for signal tracing while troubleshooting the 8340A. It is also useful in some pulse modulation applications, as explained in that section. It can also be used to set output in the presence of large reverse power (a problem described under "decoupled mode"). To do so, the reverse power's effect on the POWER dBm display must be eliminated by shutting that power off, or temporarily setting the HP 8340A's attenuator to a high value. Then, in the unlevelled mode (SHIFT METER), use the knob to set the desired ALC level via the power dBm display (remember to mentally compensate for any attenuation in use). Then remove attenuation or turn on the reverse power. In the presence of reverse power, the POWER dBm display will change to an incorrect value, but the output power will be as previously set.

EXTERNAL LEVELING

In externally leveled operations, the output power from the HP 8340A is detected by an external sensor. The output of this detector is returned to the HP 8340A's leveling circuits, and the output power is automatically adjusted to keep the power constant at the point of detection. Figure 3-32 shows a basic external leveling arrangement. The output of the detected arm of the splitter or coupler is held constant. If the splitter response is flat, then the output of the other arm will be constant also. This arrangement offers superior flatness over internal leveling, especially if long cables are involved. For best flatness a good resistive splitter with power meter detection should be used.

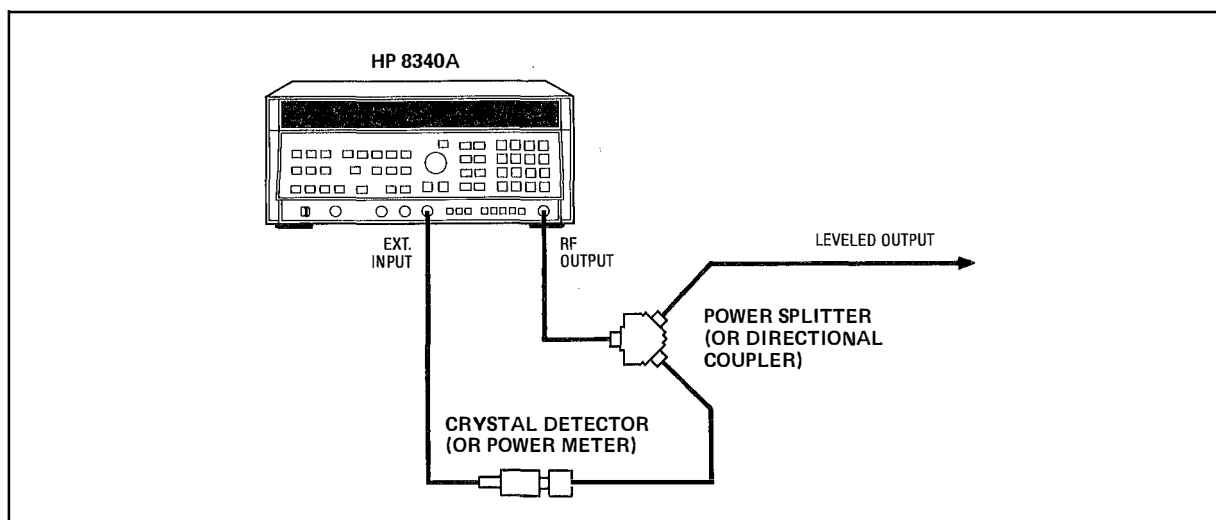

Figure 3-32. Typical External Leveling Hookup

Reference to Figure 3-29 indicates that when externally leveled, the power level feedback is taken from the external detector input rather than the internal detector. This feedback voltage is what the loop is trying to control. For a given ALC input, the loop will adjust its output until the feedback is, for instance, 10 mV. The type of coupler or detector has no influence on this — if the loop is able, it will drive the feedback to the requested level. Since there is no inherent relationship between ALC input and the amount of externally leveled

RF power, the power level ENTRY DISPLAY shows the feedback voltage which the loop is seeking. This voltage is called the reference voltage and is displayed alongside the attenuator setting as ATTN: _____ dB, REF: _____ . _____ dBV. The entry units are dBV (dB relative to 1 volt), where 1.00 V = 0 dBV, 0.1 V = -20 dBV, etc. As with the decoupled mode of internal leveling the REF is set with the keypad or **[KNOB]** while the attenuator is set with the **[STEP]** keys. The attenuator will normally be left at 0 dB. Its use is described below.

The reference voltage may be set over a range of -66 dBV (.0005V) to +6 dBV (2.00V). This wide range accommodates a variety of detectors and leveling situations. The input accepts either positive or negative voltages automatically. For example, with REF = -20 dBV, the loop will level with an input of either +0.1V or -0.1V. The input will accept overloads of ± 25 volts with no damage. The input resistance is 1 M Ω . Figure 3-33 shows the input power versus output voltage characteristics for typical HP crystal detectors. From the chart the leveled power at the crystal detector input resulting from any reference setting may be determined. The range of power adjustment is approximately -30 dBm to +18 dBm.

Detector Characteristics

As shown in Figure 3-33, crystal detectors may be characterized by three operating regions. In the square law region ($P_{in} < -20$ dBm) the output voltage is proportional to the square of the input voltage, in other words proportional to input power. In the linear region ($P_{in} > +5$ dBm) the output voltage is directly proportional to the input voltage. Because of this, when leveling in the linear region a 1 dB reference change causes a 1 dB power change, while in square law a 1 dB reference change causes a 1/2 dB power change. This should be understood when using power sweep or AM. The power sweep function will sweep the reference by up to 40 dB, but if a square law detector is being used, the power will only sweep 20 dB. The power sweep will only be linear if the operation is entirely in square law or entirely in linear. In the transition region, the power sweep will be non-linear. As may be seen in Figure 3-33 by drawing a line between -10 dBV and -50 dBV, the worst deviation from a straight line is 3 dB of reference voltage, or 2 dB of RF power. The Amplitude modulation system is designed to be linear with a square law detector. With a linear detector, the modulation depth will be more than expected, and there will be significant distortion.

HP power meters have a rear panel output ("recorder" output) which responds linearly with power. The output is +1.00V for full scale on whatever range is selected, +.50V for 3 dB below full scale, +.10V for 10 dB below full scale. These numbers may be seen directly on the 0 - 1 "WATTS" scale on an analog power meter (e.g., HP 432, 435). This response is the same as a square law detector, so all the comments above for such detectors apply to power meters.

Setting the desired power with a non-autoranging meter (HP 432, 435) is straightforward. Assume +3 dBm is desired at the power sensor. Set the power meter on the +5 dBm range, so the desired power is 2 dB below full scale. Since the RF power changes 1/2 dB for each 1 dB reference change, set the reference for -4 dBV.

Auto ranging meters (e.g., HP 436) must be used in their range hold modes to prevent range change during blanking or other RF-off intervals. To lock the meter to the desired range, internal leveling must be used. Adjust the HP 8340A output power until the meter is on the desired power range, then press range hold. As an example, consider the HP 436: The HP 436 changes ranges every 10 dB, so if -8 dBm is desired, the reference must be set for 8 dB below full scale (REF = -16 dBV) with the HP 436 locked on the -10 to 0 dBm range. (Caution: the HP 436 range change circuits have intentional hysteresis. Setting the power to 0 dBm may place the meter on either the -10 to 0 range or the 0 to +10 range. For no ambiguity, force the meter to the middle of the range (-5 dBm, +5 dBm, etc.), then press range hold.)

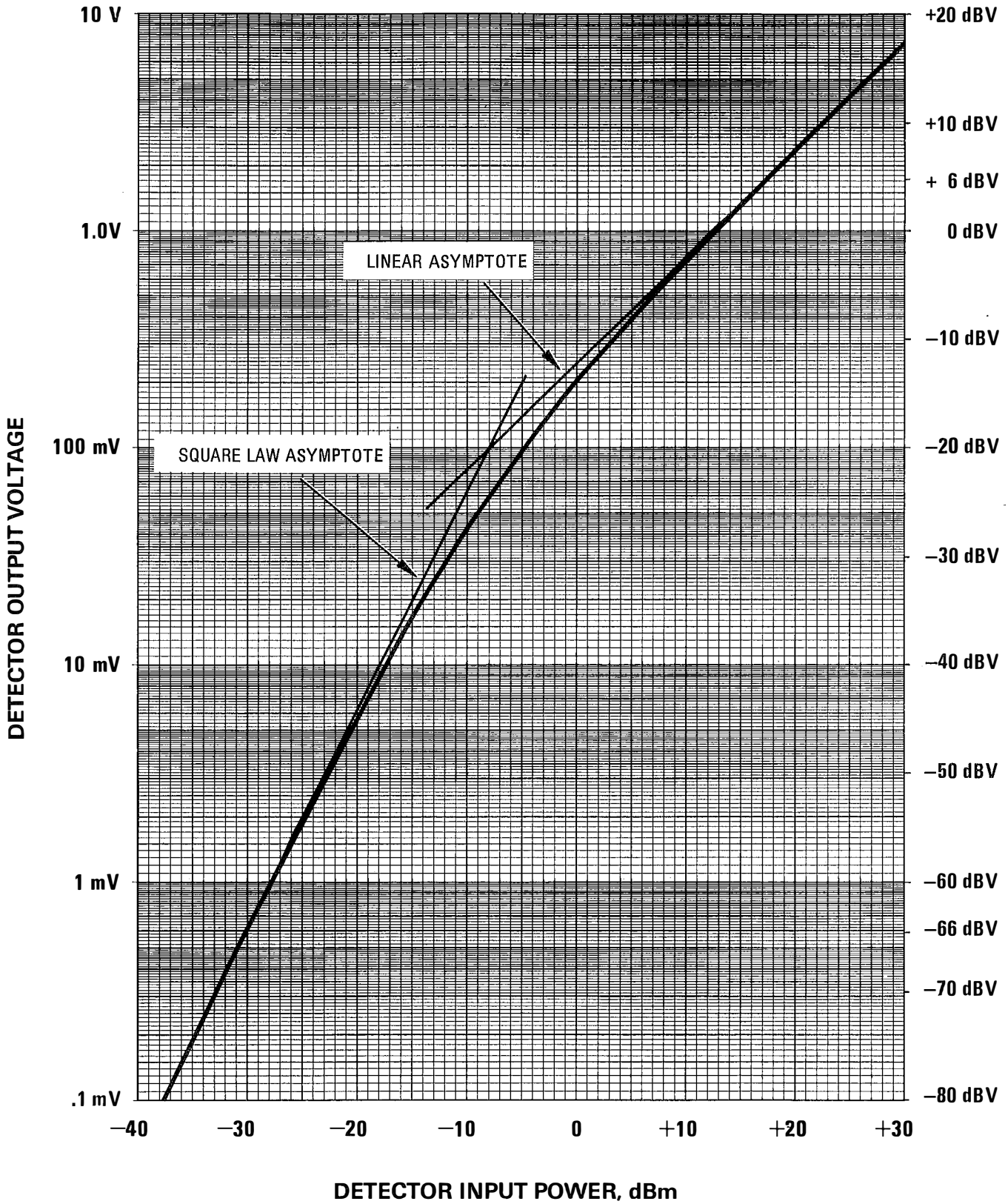

Figure 3-33. Typical Crystal Detector Response at 25°C

POWER dBm Display used with the Attenuator

Some external leveling applications require low output power from the HP 8340A, for example, leveling the output of a 30 dB amplifier to a level of -10 dBm. In this application, the output of the HP 8340A is around -40 dBm when leveled. At some frequencies this level is beyond the range of the ALC modulator alone. If so, the OVERMOD annunciator lights. Inserting 40 dB of step attenuation results in an ALC level of 0 dBm, which is well within the range of the ALC. At 26.5 GHz, where only $+1$ dBm is available, 30 dB attenuation is a better choice as it results in an ALC level of -10 dBm. This gives a margin for AM or other functions that vary the power level.

Referring to Figure 3-29, it is seen that when externally leveled the POWER dBm display is still connected to the internal detector of the HP 8340A. Thus, it always tells the true output power, regardless of external leveling setup. This is a useful aid to determining if the external hardware is functioning properly. In the above example, if the POWER dBm display shows -40 dBm when the amplifier output is leveled to -10 dBm, the user knows the gain is 30 dB. As explained in the internal leveling section above, the POWER dBm display is only accurate down to ALC levels of about -22 dBm, below which it is intentionally blanked. Therefore, that display is only useful if the ALC level is forced to be greater than -22 dBm. This is done by inserting step attenuation until the display lights up again. As still more attenuation is added, the POWER dBm reading remains essentially constant as the external leveling loop holds the output level constant. With each additional 10 dB step of attenuation, the ALC level jumps 10 dB, until finally maximum available ALC level is reached and the UNLEVELED annunciator lights. For best display accuracy and minimum noise, the ALC level should be greater than -10 dBm. This is achieved by using attenuation equal to the tens digit of output power. Example: output power = -43 dBm; use ATTN. = -40 dB, ALC = -3 dBm.

When sweeping while externally leveled, the output power changes with frequency in order to level at a distant point. The POWER dBm display tries to follow this change. Due to its heavy filtering, at fast sweep speeds the meter displays an average power level.

When using mixers, or in other situations where reverse power may be encountered, caution is necessary. See the decoupled mode and unleveled mode sections above. Reverse power into the HP 8340A when externally leveled makes the POWER dBm display read incorrectly; unwanted RF energy entering the external detector causes the loop to level at the wrong power level.

Bandwidth

When externally leveled, the leveling loop bandwidth differs from what it is when internally leveled. If AM is on or when sweeping with sweep time < 5 seconds, the nominal loop bandwidth is:

Internal: 150 kHz

External, crystal: 30 kHz with square law detector, 15 kHz with linear detector.

External, power meter: 0.7 Hz

The significance of loop bandwidth is that it generally equals AM bandwidth and influences the fastest useable sweep speed. The best way to set sweep speed is to reduce it until measured flatness no longer changes. For the sake of understanding — observe a plot of unleveled flatness across the band of interest. The number of ripples divided by sweep time gives the number of “ripples per second” which the leveling loop must remove. The

loop bandwidth must be several times this number in order to do so. From the above it is apparent that the useable sweep time will depend on frequency range and RF hardware in use. When using long cables there will be many ripples, and their amplitude is dependent on the match at each end of the cable. Inserting 10 dB of step attenuation greatly improves the source match when externally leveled, thereby reducing the ripple amplitude.

For best stability of the leveling loop, the video bandwidth of the external detector should be 50 kHz or more when XTAL leveling is selected. The capacity of coaxial cables reduces the video bandwidth of crystal detectors. A typical point-contact detector (HP 420 series, 423A, 8470A) will work with up to 15 feet of 50 Ω coax on its output. Typical HP low barrier schottky detectors (HP 423B, 8470B, 33330 series) will drive up to 100 feet of 50 Ω cable. If using a very slow detector, selecting METER leveling may work.

The above paragraph applies to square law detectors with no dc offset ($V_{out} = 0$ for $P_{in} = 0$). The following formula gives nominal loop bandwidth for arbitrary detectors (XTAL leveling):

$$BW = (\Delta V \div V_{out}) \times 120 \text{ KHz}$$

where V_{out} = dc output voltage at point of interest

ΔV = change of dc output for a 1 dB RF input change

Some unusual detectors might result in a large loop bandwidth, requiring that the detectors themselves have several times that bandwidth. Loop oscillation in XTAL mode may be encountered with loop bandwidth above 100 KHz, regardless of detector bandwidth.

In METER mode, the external leveling bandwidth is reduced to 0.7 Hz in order to allow operation with power meters. Power meters have a very slow response due to thermal delay time and heavy electrical filtering. The 0.7 Hz bandwidth assures proper operation with any HP power meter on any range. The HP 435 and 436 switch in very slow filters on their most sensitive ranges. If only the high power range is used, the loop will be stable with a higher loop bandwidth and a faster sweep can be used. The loop bandwidth can be increased by reducing the size of component A25C37. Use only a good film capacitor to avoid dc leakage problems. If this component is changed oscillations may be encountered using the bottom ranges of an HP 435/436.

When turning on the RF power, either when unblanking or using the RF key, the slow response of the power meter can cause serious power overshoot in some external leveling systems. This overshoot may damage active devices or some power sensors. To prevent this problem in the HP 8340A, a slow turn on circuit is employed when METER leveling is selected. This circuit raises the power slowly over a period of 2 seconds. The sweep generator automatically waits for this settling time to end before beginning a sweep.

Amplitude modulation is possible when power meter leveled. The system provides linear AM and is dc coupled. For rates below 0.7 Hz, the leveling is done via the power meter sensor and behaves just like internal leveling. Above 0.7 Hz, feedback from the power meter rolls off and is replaced by feedback from the HP 8340A's internal detector. Thus, high frequency envelopes are under control of the internal detector, while the power meter controls the power level. The modulation depth is still accurate and the bandwidth is nominally 30 KHz. The power sensor is not following the modulation; hence, it will average the power. When modulating with a sinusoid symmetric about 0V, the average output power increases (by 50% for 100% AM). The power sensor senses this increase and reduces the HP 8340A's output until the average equals what the power was with no modulation. As long as the modulation depth remains constant across the frequency band (use moderate rates and depths), this system will level the power while providing amplitude modulation.

AMPLITUDE MODULATION

The HP 8340A provides linear, dc coupled amplitude modulation when internally leveled or externally leveled with a square law detector or power meter. The input resistance is 600Ω whether the AM function is on or off. The sensitivity is 100% per volt $\pm 5\%$. This means that +1.0 volt doubles the output voltage (+6 dB), while -1.0 volt shuts the output completely off. The input accepts ± 15 V dc with no damage, and is resistor-diode clamped to protect against higher voltage transients. Most sine wave generators are calibrated in terms of RMS voltage, so 0.707 V RMS equals 1.00 V peak. The generator's output meter is accurate only if the load impedance equals the source impedance.

POWER dBm Display used with AM

The POWER dBm display on the HP 8340A always tells actual output power. A dc input to the AM jack causes the power level to shift, and the display reflects this: + 1.0 volt causes the display to increase 6 dB. If that much power is not available, the UNLEVELED annunciator lights and the display shows the actual output. Inputs which reduce the ALC level below -22 dBm will blank the display. Inputs of -1.0 volt or more negative shut off the output and light the OVERMOD annunciator.

The POWER dBm display is filtered so that it will not flicker for AM rates above 20 Hz. The filtering creates an average of RF voltage, which is then displayed as power in a 50Ω system (dBm, 50Ω). Therefore, modulation inputs with no dc component do not cause the POWER dBm display to shift, and this displayed number represents the power of the unmodulated carrier. A power meter measurement of output power changes with modulation present, increasing 1.76 dB with 100% deep sinusoidal, no dc component modulation. Attempted deep modulation at high rates causes the POWER dBm display to shift, because the AM system cannot keep up with the input and the resultant high distortion causes a shift in average power.

Dynamic Range

As mentioned previously with reference to Figure 3-29, the AM input is an ALC input which does not differ in its effect from a power entry input. Therefore, the AM system is limited by where it is operating within the ALC range. In the normal "coupled" operating mode, the ALC will likely be set between -10 dBm and 0 dBm (see the preceding pertinent section). Depending on frequency, the maximum available power is between +1 dBm and +21 dBm. The ALC is reasonably accurate down to -20 dBm, and typically is well behaved to about -30 dBm. Expressing the desired modulation depth in dB's will let the user determine the range over which the ALC loop is being exercised. Thirty percent AM creates excursions of +2.3 dB to - 3.1 dB, relative to the quiescent level; 50%: +3.5 dB to -6.0 dB; 90%: +5.6 dB to - 20.0 dB. (The above assumes a modulation waveform symmetric about 0 V.)

For example: Output power = -19.0 dBm. In coupled mode this results in ATTN = -10 dB, ALC = -9.0 dBm. Ninety percent modulation depth results in an ALC range of -9.0 dBm + 5.6 dB = -3.4 dBm maximum, -9.0 dBm - 20 dB = - 29.0 dBm minimum. This is within the ALC limits at any frequency but the distortion may suffer due to operation below -20 dBm. Using decoupled operation the desired output power may be set with ATTN = -20 dB, ALC = +1.0 dBm. Then 90% depth swings the ALC from +6.6 dBm to -19.0 dBm. The distortion will probably be better under these conditions if +6.6 dBm is available at the frequency of interest. At some frequencies +20 dBm is available, and setting ATTN = -30 dB, ALC = +11.0 dBm may give a further improvement, especially if attempting greater than 90% depth. For minimum distortion the ALC should be used between -15 dBm and +15 dBm, but not within 2 dB of maximum available power.

Above 23 GHz the available output power is limited: +1 dBm specified, +3 dBm typical. If the ALC is set close to 0 dBm, the headroom available for modulation is limited. Three dB excess power allows a maximum of 40% peak modulation. The available depth is not affected. Decoupled mode may be used to advantage here. For example, in coupled mode an output power of -10 dBm results in ATTN = 10 dB, ALC = 0.0 dBm. Using decoupled mode, setting ATTN = 0 dB, ALC = -10.0 dBm gives plenty of headroom with enough depth available for 90% symmetric AM. Available power can be maximized at a CW frequency by using the PEAK function.

Bandwidth for AM Applications

The small signal AM bandwidth extends from dc to a -3 dB frequency of at least 100 KHz. The actual upper limit is a direct function of the loop gain of the ALC loop. The primary variable in the loop gain is the gain of the modulator, which varies with both power level and frequency. In general, the modulator gain deviates the most from nominal at power levels just below maximum, although at some frequencies the gain will deviate at lower power levels because of non-optimum YTM bias. The latter is only a problem above 7.0 GHz. The small signal (30% depth) bandwidth may be expected to vary between 100 KHz and 300 KHz as power and/or frequency is changed. The bandwidth for greater depths is less. At 90% depth expect about 1/5 the 30% bandwidth.

The above bandwidths are for internal leveling. When external leveling with a crystal detector in its square law region the bandwidth is 1/5 of the internally leveled bandwidth at the same frequency and output power level. With a crystal detector in its linear region, the bandwidth is 1/10. For other detectors see the external leveling section.

The external leveling system is designed to provide linear AM when using a square law detector. The RF output follows this law:

$$V_{out} = V_o \times (V_{in} + 1).$$

This applies also to internal leveling. When externally leveled with a linear detector the relationship is:

$$V_{out} = V_o \times (V_{in} + 1)^2$$

A power meter is a square law detector, so AM with power meter leveling is linear. For bandwidth see the external leveling section.

For simultaneous AM and pulse modulation, see the next section.

PULSE MODULATION

The HP 8340A provides leveled pulse modulation over a wide range of pulse widths and rates. Characteristics such as leveling accuracy and response time vary with pulse width, pulse rate, temperature, power level, and RF frequency. In order to use the pulse leveling system to best advantage it is helpful to understand its operation and limitations.

Sample and Hold Leveling

The basic leveling loop was previously explained with reference to Figure 3-29. Fundamental to its operation is the internal detector which measures the RF amplitude. The leveling performance is limited by the accuracy of this measurement. The most difficult aspect of leveled pulse modulation is measuring the amplitude of a very narrow RF pulse.

Figure 3-34 is a block diagram of the detector circuitry, with waveforms. Trace 1 is the pulse modulation input signal to the HP 8340A. It controls a fast RF modulator which is either full on or full off. The amplitude when on is controlled by the linear modulator used for CW leveling and AM. Trace 2 is the resultant RF pulse, which is the HP 8340A's output. This pulse is detected by the crystal detector. It trails the pulse input by 55 nsec, representing propagation delays in the pulse modulator and its drive circuits.

The output of the crystal detector is amplified by a logarithmic amplifier (log amp). The log amp is used for several reasons, one of which is its high gain for small signals, reducing the effects of sample and hold errors. Trace 3 is the output of the log amp. The delay and relatively slow rise time are caused by the finite bandwidths of the detector and log amp. The pedestal (arrow) represents the RF amplitude. This level is captured for further processing by the sample and hold circuit (S/H), represented by the switch-capacitor combination. Trace 4 shows the signal controlling the switch, which is closed when trace 4 is high.

Trace 4 is timed to coincide with the pedestal of trace 3. This timing is done by circuitry associated with the pulse modulator and is factory adjusted for best coincidence. Since the S/H switch is closed only during trace 3's pedestal, the capacitor charges to a constant dc voltage. This voltage is the same as what comes out of the log amp during CW operation at the same power level. The capacitor is isolated by a buffer to prevent the following circuits from discharging it between pulses. The output of the buffer is compared to the ALC inputs in the same manner as with CW operation.

Figure 3-34 shows a 200 nsec pulse. If the pulse were narrowed to 100 nsec, trace 3 would not quite reach its pedestal before it begins to fall. The result is a dc output from the S/H that is smaller than it would be in CW. The ALC circuits respond by raising the RF output until that voltage is what it should be. This is the reason for poor leveling accuracy with narrow pulses. As the pulses are made narrower, their amplitude grows.

The amount of accuracy degradation as the pulses are narrowed varies with frequency, temperature, and power level. The variation with frequency and temperature is due to detector characteristics and RF envelope shape. The detector has a finite rise time determined by its output resistance and shunt capacitance. At some frequencies there is a slight amount of overshoot on the RF envelope, which tends to charge the shunt capacity faster, resulting in better narrow pulse leveling accuracy. A much more pronounced effect is due to the use of a different detector for frequencies below 2.3 GHz. The low band detector has a higher shunt capacity in order to make it function properly at low frequencies. For operation below 400 MHz, a large amount of additional capacity is switched in, enabling detector operation down to 10 MHz. Trace 3 in Figure 3-34 is representative of operation above 2.3 GHz, where pulse accuracy is within 1.5 dB at 100 nsec. From 0.4 to 2.3 GHz, the slower rise time gives a 1.5 dB specification at 200 nsec width. Operation below 0.4 GHz is not specified, but typically is within 1.5 dB at 2 μ sec width.

The detector's rise time depends on its output resistance, which drops with increasing temperature. Therefore, the narrow pulse leveling accuracy improves at higher operating temperatures.

Narrow pulse accuracy is also power level dependent. Very high ALC levels reduce the detector's output resistance, improving rise time and therefore accuracy. The rise time of a log amp is dependent on signal level, degrading with small signals. In low band (< 2.3 GHz) the log amp is faster than the detector at any ALC level above -10 dBm, so there is no degradation due to the log amp in any coupled mode operation. In high band, the log amp rise time at ALC = -10 dBm is slow enough to be comparable to the detector rise time. Therefore, as power is decreased, the leveling accuracy slightly degrades (narrow pulse amplitude grows relative to CW).

(A) DETECTOR CIRCUITRY

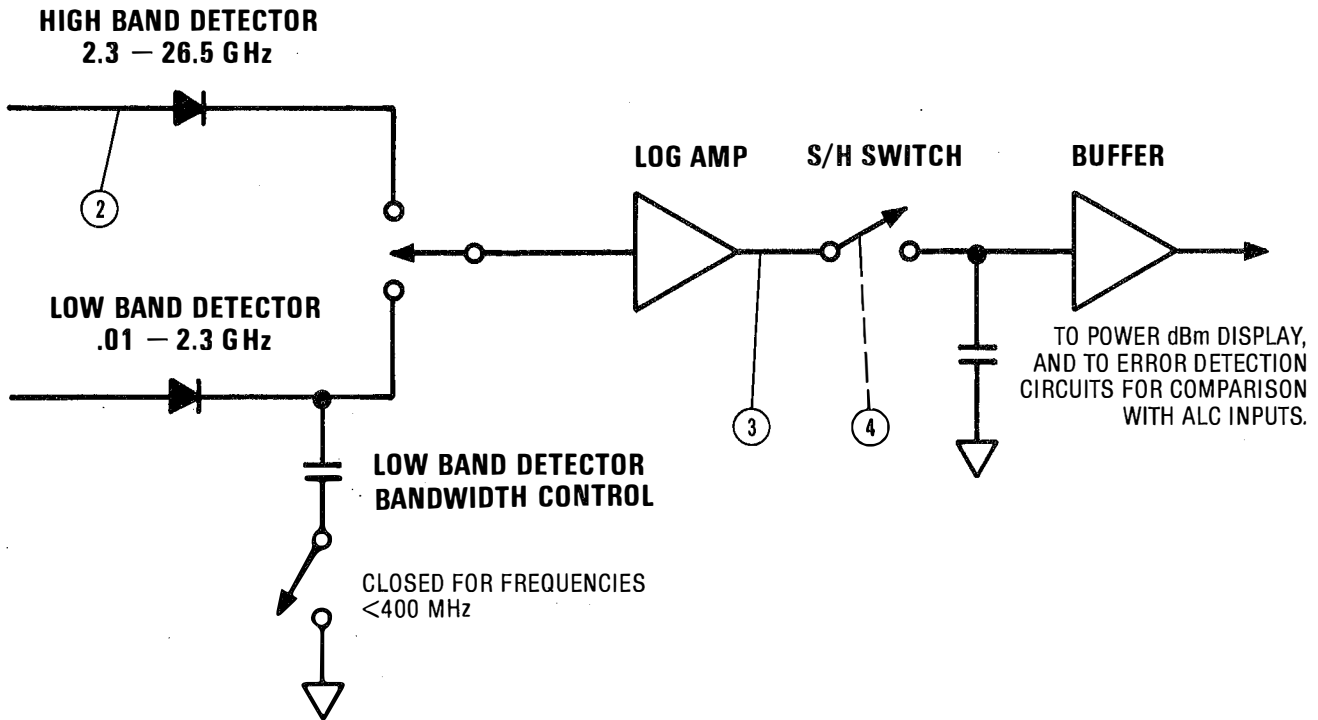

(B) PULSE WAVEFORMS, 50nsec/DIV.

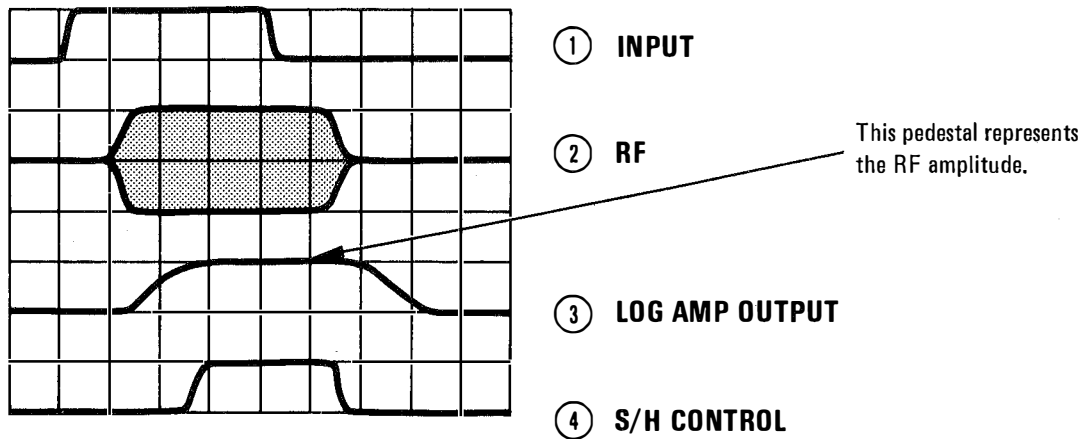

Figure 3-34. Pulse Measuring System

The leveling specifications apply to coupled operation, with no AM; in other words, $ALC > -10$ dBm. Using decoupled mode or AM, the ALC level can be driven down to -20 dBm or lower. At -20 dBm, the log amp slows down enough that high band accuracy is typically 1.5 dB at 150 nsec, 3.0 dB at 100 nsec. Decoupled mode can also be used to operate the ALC at high levels and achieve better narrow pulse accuracy.

The above discussion applies to internal leveling only. Externally leveled pulse performance will, of course, depend on the detector, but even with a perfect detector the external leveling circuitry is not as fast. It typically will level pulses as narrow as $1 \mu\text{sec}$, for detector outputs above -40 dBV. An HP low barrier schottky detector driving 4 feet of 50Ω cable will realize this performance, but a point contact type driving 4 feet of cable will slightly degrade performance at $1 \mu\text{sec}$.

Another type of leveling error arises from long pulse periods (low repetition rates), or more precisely, long off times between pulses. The problem lies in the error detection and modulator drive circuits shown in Figure 3-35. On the left is the comparison point, where the ALC input is compared to the detector output. For this discussion assume the two resistors are equal in value, so if the ALC and detector voltages are equal in magnitude but opposite in polarity, the error signal will be zero. The error is fed to an integrator through the integrate/hold switch. This switch is closed continuously during CW operation. Any error signal causes the integrator output to change at a controlled rate (determined by capacitor C), changing the RF output via the linear modulator. The integrator output continues to change until its input is zero, which means the detector voltage is balancing the ALC input voltage. The time required to cancel an error is about $70 \mu\text{sec}$ ($4 \mu\text{sec}$ with AM on or when sweeping fast, under which conditions a smaller value of C is switched into the circuit).

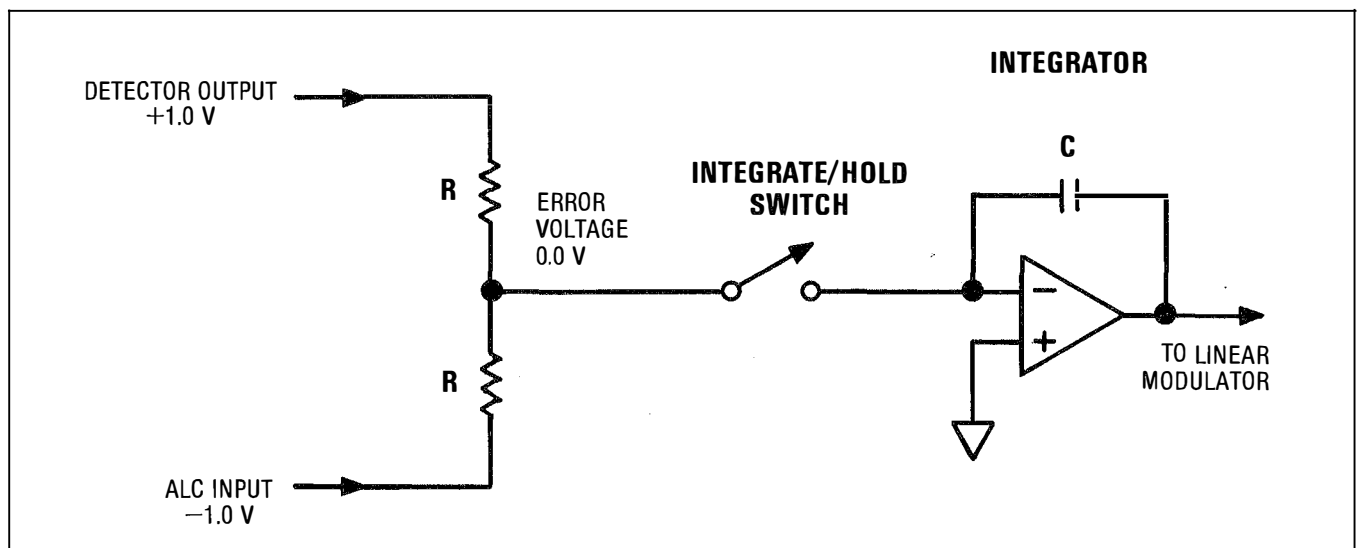

Figure 3-35. Error Detection and Modulator Drive

Consider now pulse operation with a period of 1 msec. The detector S/H measures a pulse and holds its value until the next pulse. Assuming an error is present, the integrator responds to that error, reaching the proper modulator drive in about $40 \mu\text{sec}$. Since the detector S/H is still holding the error from the last pulse, the integrator keeps changing until the next pulse, overshooting its mark and causing instability. For this reason the integrate/hold switch is only closed during a pulse. During the period between pulses, the switch is opened, thus the integrator input is zero so the modulator drive doesn't change. This assures that the amplitude at the beginning of the next pulse is the same as at the end of the previous pulse. Corrections take place only during the pulses, until equilibrium is reached.

Since this may cause very long response times for narrow pulses, the integrate/hold switch is held closed a minimum of 10 μsec per pulse, for pulses narrower than that. This is not long enough to cause overcorrections but speeds response time for 100 nsec pulses by a factor of 100.

During the period between pulses, the integrate/hold circuit is expected to hold the modulator drive constant. Because of leakage currents, the output will in fact drift, causing the pulse amplitude to be in error. This error will grow with off time and also temperature, as leakage is strongly temperature dependent. The circuit is designed worst case for < 0.1 dB droop in 10 msec at an ambient temperature of 55°C. At 25°C, a typical unit drifts about 1 dB per minute. The drift may be in either direction.

Response Time

A tradeoff exists between response time and drift between pulses. Reducing C in Figure 3-35 speeds response to a level change, but also increases drift rate. Some applications require faster response than the HP 8340A's normal operating mode provides. The fast response mode is activated by pressing **[SHIFT] [AM]**, which simultaneously turns on AM. This mode is also activated when sweeping with sweep times shorter than 5 seconds. In this mode response is 20 times faster than normal, and worst case droop is 0.2 dB in 1 msec at 55°C.

The response time to a step change in level is a function of pulse width and rate and is detailed in the specifications. The response time is a function of ALC loop bandwidth, which varies with frequency and power as explained in the AM section. The listed response characteristics apply at the minimum expected loop bandwidth. An intuitive feeling for response may be gained by the following: At minimum bandwidth in CW it takes 70 μsec to respond to a change and settle to within 10% of the size of the change. In pulse mode, the same degree of settling requires 70 μsec of closure of the integrate/hold switch. This may come from one 70 μsec pulse, two 35 μsec pulses, etc. Any pulse less than 10 μsec wide is treated as a 10 μsec pulse. If the pulse *period* is less than 10 μsec , the integrate/hold switch is continuously closed, so the system responds in 70 μsec regardless of width or period. In fast response mode the basic time is 4 μsec and the minimum integration time is 1 μsec .

Simultaneous AM and pulse modulation is provided by the HP 8340A. The AM is dc coupled and linear, just as with normal CW leveling. If AM is used to exercise the ALC below -10 dBm, the narrow pulse leveling accuracy degrades as explained above. The bandwidth is given by the equation: $3\text{dB BW} = 0.35/\text{Tr}$, where Tr is the response time to a step change described above. The pulse leveling system is in its slow response mode when the AM key is pressed. SHIFT AM activates the fast response mode as well as enabling the AM circuits.

Pulse modulation while sweeping is also possible. The permissible sweep rates are a function of response time, which is a function of pulse width and rate. Sweep times less than 5 seconds activate the fast response mode. The response time should be short compared to the time needed to sweep across each unlevelled ripple. See the sweep speed discussion in the external leveling section. Note: If the start frequency is less than 400 MHz, the low band detector will lock in its low bandwidth state for the entire band 0 portion of the sweep. This effectively precludes leveling pulses narrower than 2 μsec .

Unlevelled Mode Used With Pulse Modulation

Decoupled operation may be used for dynamic range extension or any of the other uses described for CW or AM. Several pulse related problems may be treated with the unlevelled (**[SHIFT] [METER]**) operating mode already described.

Narrow pulse leveling accuracy problems may be treated by simply not attempting to level them. The unlevelled mode allows the user to control the linear modulator directly. The setting of this modulator does not change with pulse width, so the pulse amplitude remains constant as the pulse is narrowed. Pulses as narrow as 25 nsec may be produced in this mode. To set the amplitude, go to CW operation (pulse off) and set the desired power via the POWER dBm display.

As the pulses are narrowed, the POWER dBm reading drops since it is measuring the output of the detector S/H system and it is the limitations of this system which cause the narrow pulse leveling problems. The real amplitude remains essentially constant, however. In unlevelled mode, the POWER dBm display accuracy is the complement of the corresponding leveled pulse accuracy; that is, $-1.5 \text{ dB} + 0.3 \text{ dB}$ for width = 100 to 200 nsec, frequency $\geq 2.3 \text{ GHz}$. If operating close to maximum ALC output there is some amplitude drift (a few tenths of a dB) due to component self-heating when going from 100% duty cycle to low duty cycles.

Since unlevelled mode does not involve the integrate/hold circuit, there is no leakage induced amplitude drift between pulses. Consequently, very long periods may be employed that are limited only by the long term drift of the modulator drive circuits. This is not negligible and should be characterized by the user at the frequency of interest. Drifts of a few dB should be expected during warmup. Since this mode is not feedback leveled, the power changes markedly with frequency.

In unlevelled mode the ALC inputs control the linear modulator directly, so the response time is not dependent on pulse parameters. The response time is 70 μsec maximum in CW, sweeps > 5 seconds, normal AM; or 4 μsec maximum for sweeps < 5 seconds or with **[SHIFT][AM]**. AM works in unlevelled mode, but the linearity and sensitivity varies with power level and frequency. See the pertinent preceding section.

Input Characteristics

When pulse mode is activated, the HP 8340A's RF output is controlled by the voltage at the pulse input. The input circuit is shown in Figure 3-36. The output is off for inputs below approximately +1.5 V. If the input is left open it pulls itself up to +1.8 V, which will turn the output on. The HP 8340A's delay and compression specifications assume an input of 0 to +3.0 V, which requires sinking about 1.6 ma and sourcing about 2.7 ma respectively. The input accepts +12 V to -20 V with no damage, which is compatible with the $\pm 6 \text{ V}$ modulator drive of certain network analyzers. Aside from small effects on delay and compression, the waveform and amplitude of the input is unimportant, as long as it transitions from +0.5 to +2.5 V in 2 μsec or less. This transition is sufficient to generate the fastest rise time. Since the input is not linear, input overshoot will not appear on the output.

Some applications may require a 50 Ω input. One simple solution is a 50 Ω feedthrough termination. In the case of special configurations with rear panel inputs, the long length of unterminated internal cable may still cause reflection problems. If so, R14 (circuit board A21) may be replaced with a 50 Ω resistor. The consequences are that the input no longer pulls up when open, so activating pulse mode with no input will shut off the RF output. With a 1/4 watt resistor the damage level is $\pm 3.5 \text{ V}$. A 3/4 watt rating is needed to accept the $\pm 6 \text{ V}$ drive from certain network analyzers.

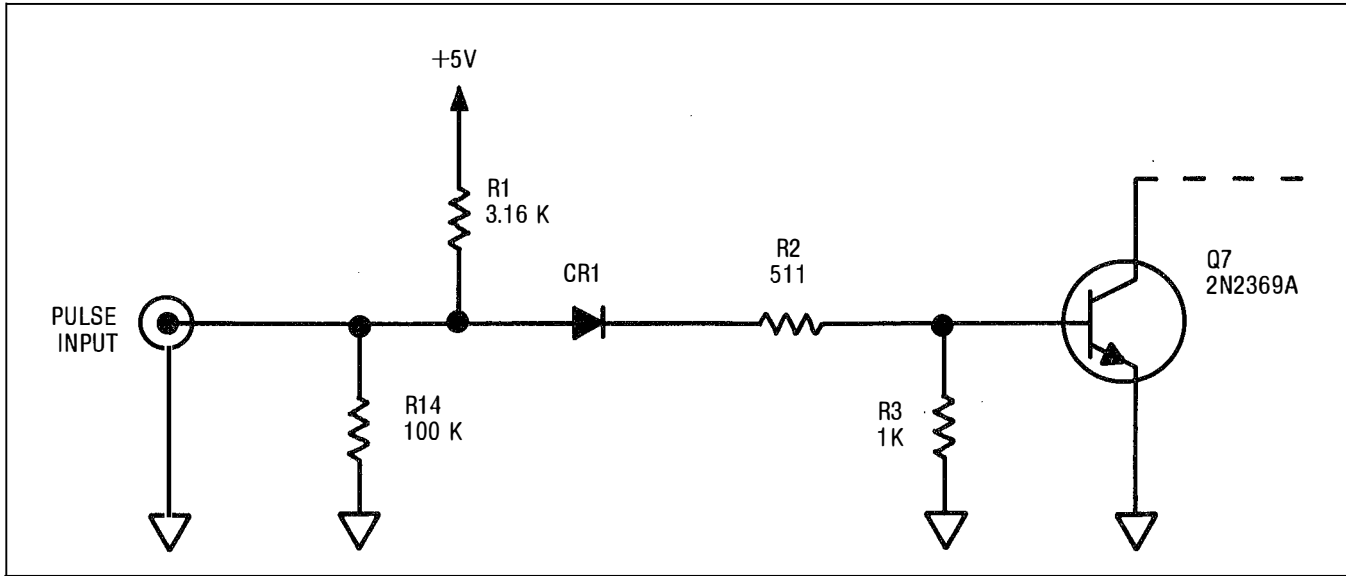

Figure 8-36. Pulse Input Circuit

Pulse Envelope

The pulse envelope produced by the HP 8340A is not a perfect rectangle, rather it has finite rise time, overshoot, and video feedthrough. Below 2.3 GHz the rise time and overshoot are essentially independent of frequency, but above 2.3 GHz they are strongly influenced by the passband shape and centering of the HP 8340A's tracking YIG filter. Best envelopes are normally obtained by using the PEAK function. The envelopes will change with frequency and slightly with power level.

Source Match

In the absence of attenuation with a resistive pad, a leveled microwave source generally provides a 50Ω source match at its operating frequency only. The source match at other frequencies is that of the unlevelled RF hardware. In this case this is a YIG filter which is a good reflection for anything more than about 20 MHz off center, and not much better within its passband. The match is good only for signals at the output frequency plus or minus the leveling loop bandwidth. Thus a CW reflection will be absorbed. A time varying reflection, as from a reflective modulator, may contain modulation sidebands outside the leveling loop bandwidth. If so, these sidebands may be re-reflected. When pulse modulating, any reflection of the pulse will contain sidebands far outside the loop bandwidth, so the leading edge of the reflection will be re-reflected. In this manner a poorly matched system can generate very poor envelopes (anywhere in the system, not only at the source). Performance is improved by padding between the reflections. At the source, if output powers above -10 dBm are in use, coupled mode results in 0 dB RF attenuation. If enough power is available, decoupled mode may be used to improve the HP 8340A's source match by inserting 10 dB attenuation and using a 10 dB higher ALC level.

Video Feedthrough

Video feedthrough is a low frequency signal, at the modulation rate, which is superimposed on the RF envelope. See Figure 3-37. If large enough, video feedthrough can disturb mixer balance, amplifier bias, crystal detector output, etc. Since it is low frequency energy, it can disturb systems which are not intended to deal with it, especially demodulation systems.

The HP 8340A's high band (> 2.3 GHz) employs a tracking YIG filter which essentially eliminates video feedthrough. Attempts to measure it can turn out to be measurements of ground currents in coaxial cables. The HP 8340A's low band (< 2.3 GHz) employs a low level mixer followed by a high gain amplifier. At high power levels, the bias levels in the amplifier shift slightly as the RF is turned on or off. The slew of the bias from one level to another couples to the output and produces the video feedthrough waveform. For this reason the 5% specification is only valid for power levels up to +8 dBm. At low ALC levels (-10 dBm), another mechanism predominates. Mixer imbalance produces dc at the output of the mixer, and its magnitude varies with RF amplitude and/or modulator state. This shifting dc level couples through the amplifier, which is AC coupled, and emerges as video feedthrough spikes. In percentage terms this mechanism gets worse at low levels. The lowest percentage video feedthrough is probably found at ALC levels around 0 dBm.

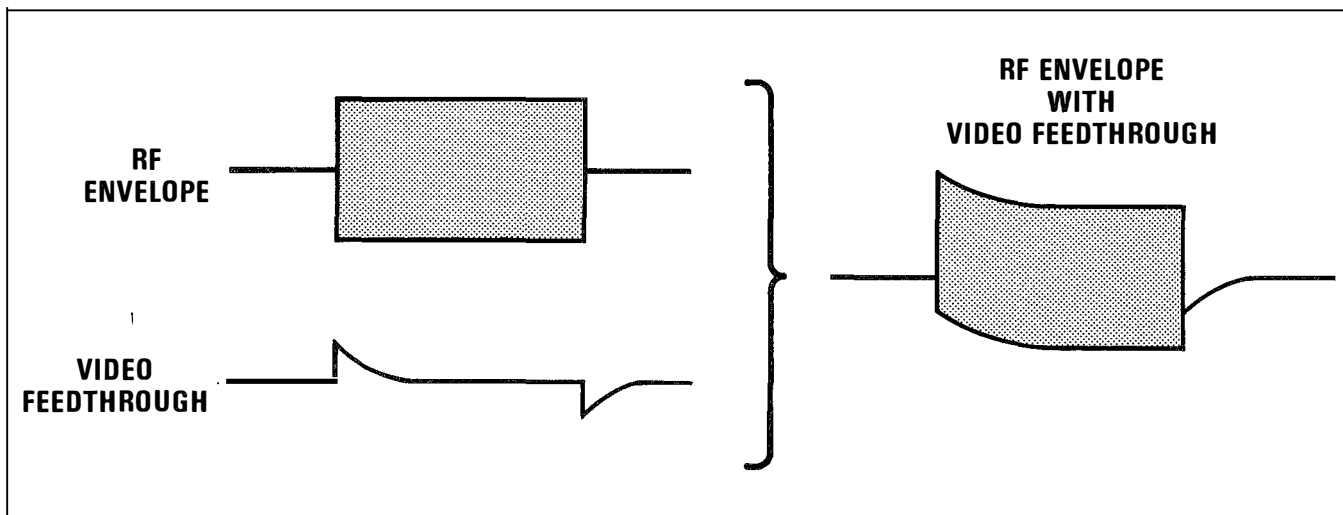

Figure 3-37. Video Feedthrough

FURTHER INFORMATION

This completes Section III of the HP 8340A Synthesized Sweeper Operating and Service Manual. For further information, there are several Programming Notes, Operating Guides, general-reference Application Notes, and a Manual Changes Supplement that are applicable to the HP 8340A; all of these are available from Hewlett-Packard Sales and Service Offices (listed inside of back cover).



Part of HP Part No. 08340-90022

Printed in U.S.A.

Externally Leveling the HP 8340A Synthesized Sweeper

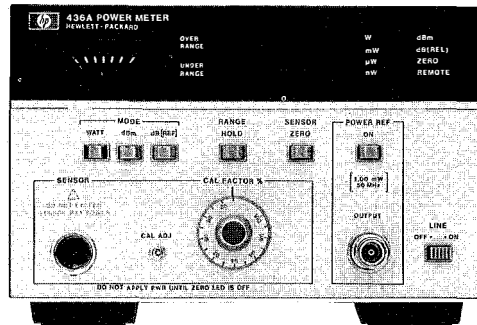

EXTERNAL LEVELING THE HP 8340A

The output power of the HP 8340A may be externally leveled. A typical setup for external leveling uses either a power splitter or a directional coupler to sample a portion of the RF output signal. This sampled signal is detected to produce a dc voltage proportional to the RF output level. This voltage is compared to a reference voltage in the ALC circuit inside the 8340A to reduce the power level variations over the frequency range. Directional couplers are usually narrowband devices, whereas a power splitter has a flat frequency response over a wide frequency range. The advantage of a directional coupler is that it does not have as great a main line loss as the 6 dB loss incurred when using the power splitter; therefore, a higher maximum leveled power output may be obtained.

CRYSTAL LEVELING

A listing of crystal detectors, directional detectors, directional couplers, and power splitters that can

be used from 10 MHz to 26.5 GHz is shown in Table 1. Connect the equipment as shown in Figure 1. Then perform the following:

1. Press **INSTR PRESET** on the 8340A and enter the desired functions (CW or swept mode) and data (desired CW frequency or sweep limits).
2. If a sweep mode is used, set the frequency to the center of the frequency range by pressing the **CW** key and then the appropriate frequency value.
3. Press the **XTAL** leveling key, then use the knob on the 8340A to adjust the REFERENCE level (shown in the ENTRY DISPLAY) for the desired output power reading on the HP 436A Power Meter. (The power meter is used only for accurate setting of the power level and is not otherwise needed for crystal leveling. If a power meter is not available, the leveled output power may be set by observing the POWER dBm display on the 8340A as the REF level is adjusted.

Table 1. Equipment for Crystal Leveling, 0.01 to 26.5 GHz

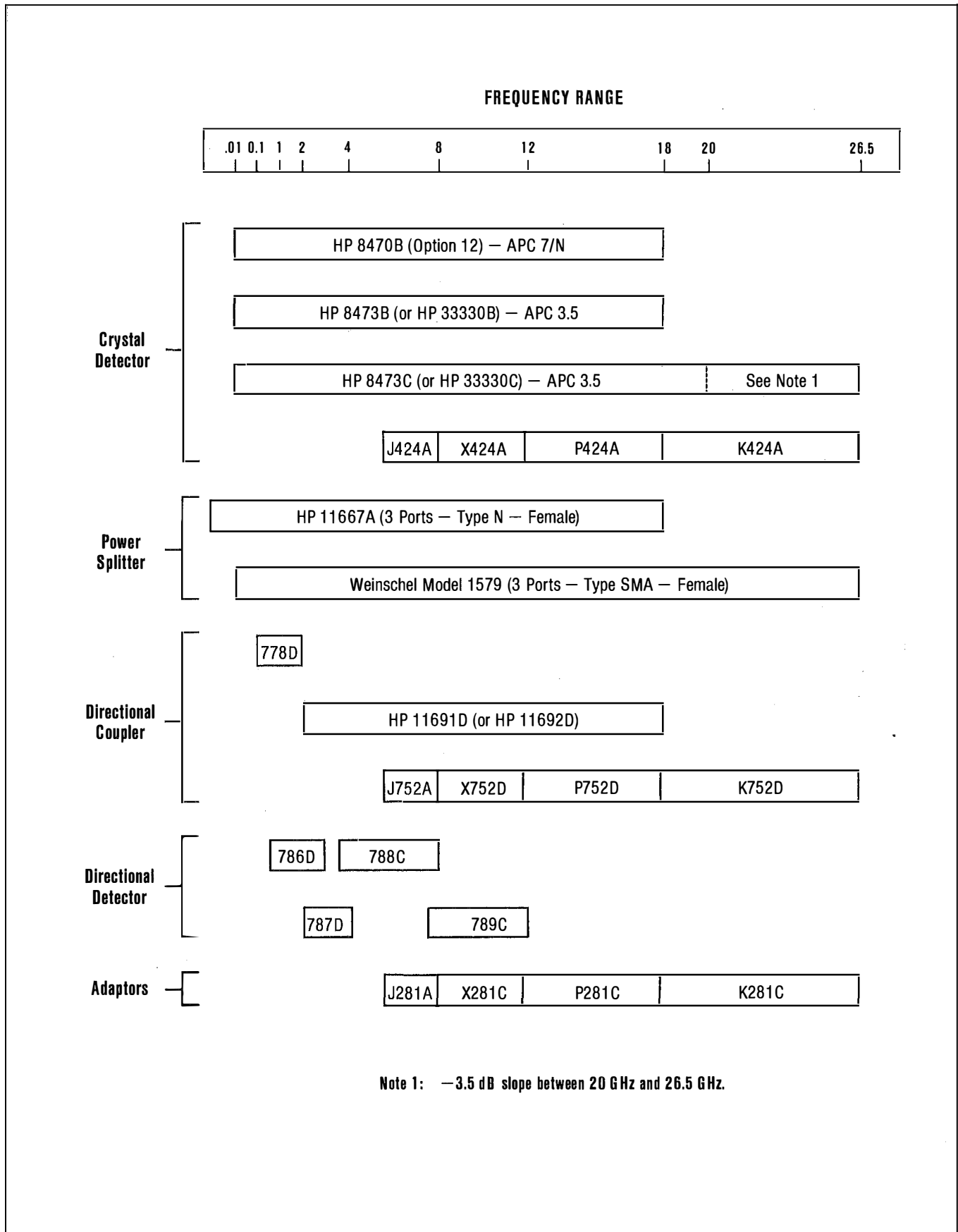

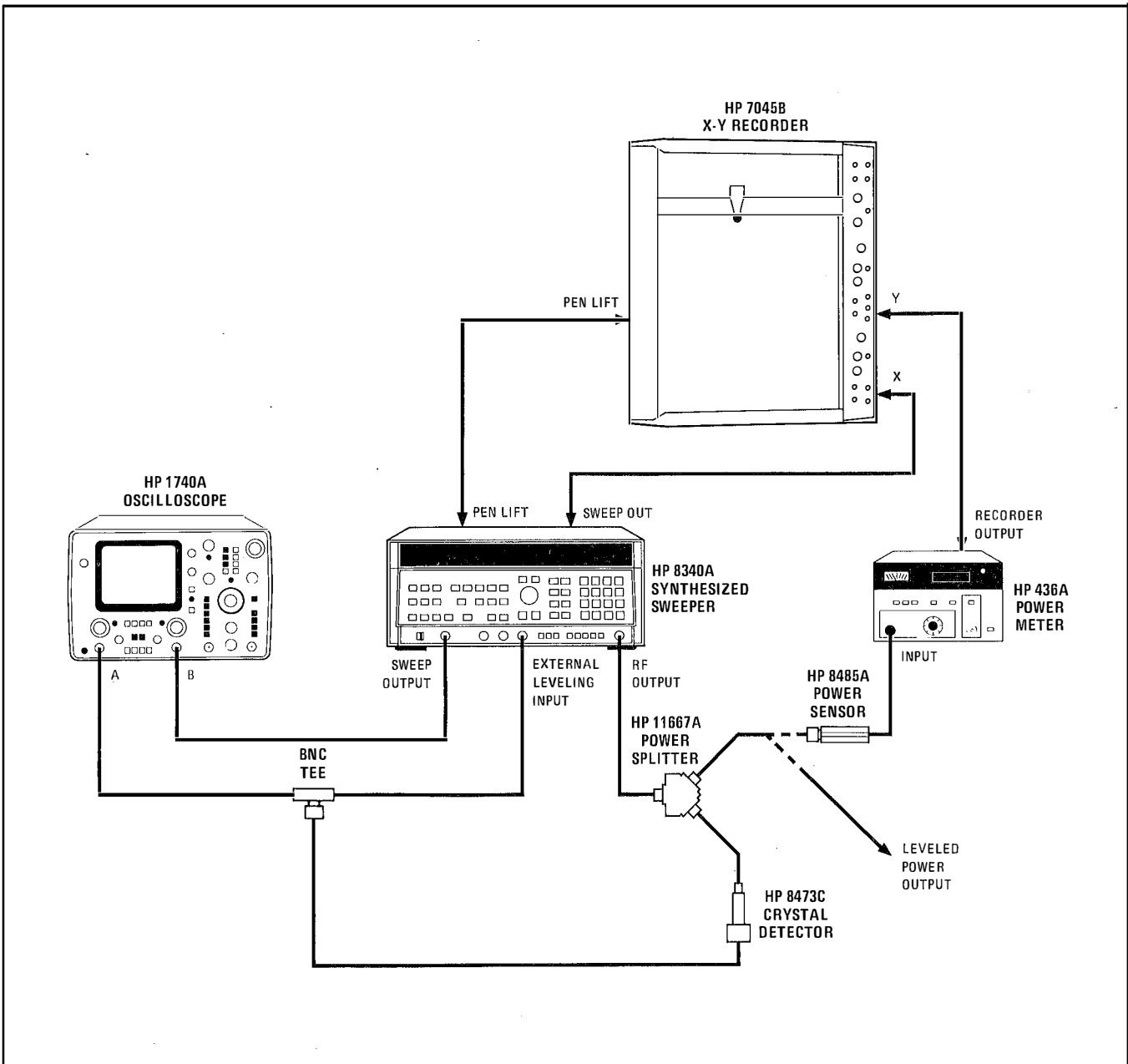

Note

1. Using the HP 11667A Power Splitter, APC 3.5 to N (or SMA to N) adapters must be used for the following connections:

| | |
|------------------------------|-------------|
| RF Output | APC 3.5 (m) |
| 8473C Crystal Detector | APC 3.5 (m) |
| 8485A Power Sensor | APC 3.5 (m) |
2. The HP 1740A Oscilloscope is placed in A vs B function.

Figure 1. Typical Equipment Setup for Crystal Leveling

The POWER dBm reading, minus the 6 dB of loss from the power splitter, gives a very good approximation of the value of the leveled output power.)

NOTE

The crystal output signal must be between 316 μ V and 3.16 V (-70 dBV to +10 dBV). If desired, the voltage may be checked on an oscilloscope using the setup shown in Figure 1.

4. Then return to the sweep mode.

If a plot is required, an HP X-Y recorder can be used. (Refer to the "Operation with X-Y Recorders" section of this manual). The recorder output of the 436A Power Meter is used to drive the Y input of the recorder. Due to the slow response of the HP 8485A Thermocouple sensor, a slow sweep speed must be selected during the plot. A minimum sweep time of 50 seconds for a full 10 MHz to 26.5 GHz sweep is recommended.

NOTE

When the 8340A is swept over multiple bands, the RF is momentarily turned off at the band switchpoints. This can create a problem if the 436A is in AUTOSCALE, because the drop in RF power will cause the 436A to switch to a new 10 dB range. Since the RECORDER OUTPUT is 0 to 1 V for each 10 dB range, a range change will cause a spike in the X-Y recorder trace. To avoid this, put the 436A Power Meter in RANGE HOLD.

POWER METER LEVELING

All of the HP 432A/B/C, 435B and 436A Power Meters and their corresponding sensors, thermistor mounts or thermocouples can be used for external leveling of the 8340A. Connect the equipment as shown in Figure 2. Equipment recommended for power meter leveling from 10 MHz to 26.5 GHz is shown in Table 2.

Proceed as follows:

1. Press **INSTR PRESET** on the 8340A, then enter the desired functions (CW or swept mode) and data (desired CW frequency or sweep limits).
2. If a sweep mode is used, set the frequency to the center of the frequency range by pressing the **CW** key and then the appropriate frequency value.

3. Then adjust the 8340A power level for the desired power output, reading the power level on either of the 436A power meters.

4. Press **HOLD RANGE** on both 436A Power Meters.

5. Then press **METER** leveling on the 8340A.

6. Then readjust the power level on the 8340A if necessary, by using the knob to adjust the REF level (shown in the ENTRY DISPLAY).

7. Return the 8340A to the sweep mode.

NOTE

This procedure can be shortened by omitting Steps 3 and 4 when using either an HP 432A or an HP 435A Analog Display Power Meter. But when an HP 436A Digital Display Power Meter is used, special care is needed to adjust the power level to the desired value. The reason is that the RECORDER OUTPUT signal from the 436A used to drive ALC loop varies from 0 to 1 V for each 10 dB full scale range on the 436A. The procedure described above presets the power level in the 8340A's INTERNAL leveling mode. Then **HOLD RANGE** is pressed on the power meters to avoid any large variations of the detected power in the ALC loop when the 8340A is set to **METER** leveling.

Due to the fact that thermistor mounts and thermocouples are very slow-response devices, the 8340A sweep time must be increased to the following recommended values:

Thermocouple (848X):

More than 50 s for full 10 MHz to 26.5 GHz sweep

Thermistor mount:

Typically 50 s for full 10 MHz to 26.5 GHz sweep

If a plot is required, an HP X-Y analog recorder may be used. (Refer to the "Operation with X-Y Recorders" section of this manual). The recorder output of the second 436A Power Meter is used to drive the Y input of the Recorder. Figure 3 shows a typical output power leveling plot from 10 MHz to 26.5 GHz using a 436A Power Meter and an 8485A Power Sensor. The output power is 0 dBm at the 8340A output connector.

Table 2. Equipment for Power Meter Leveling, 0.01 to 26.5 GHz

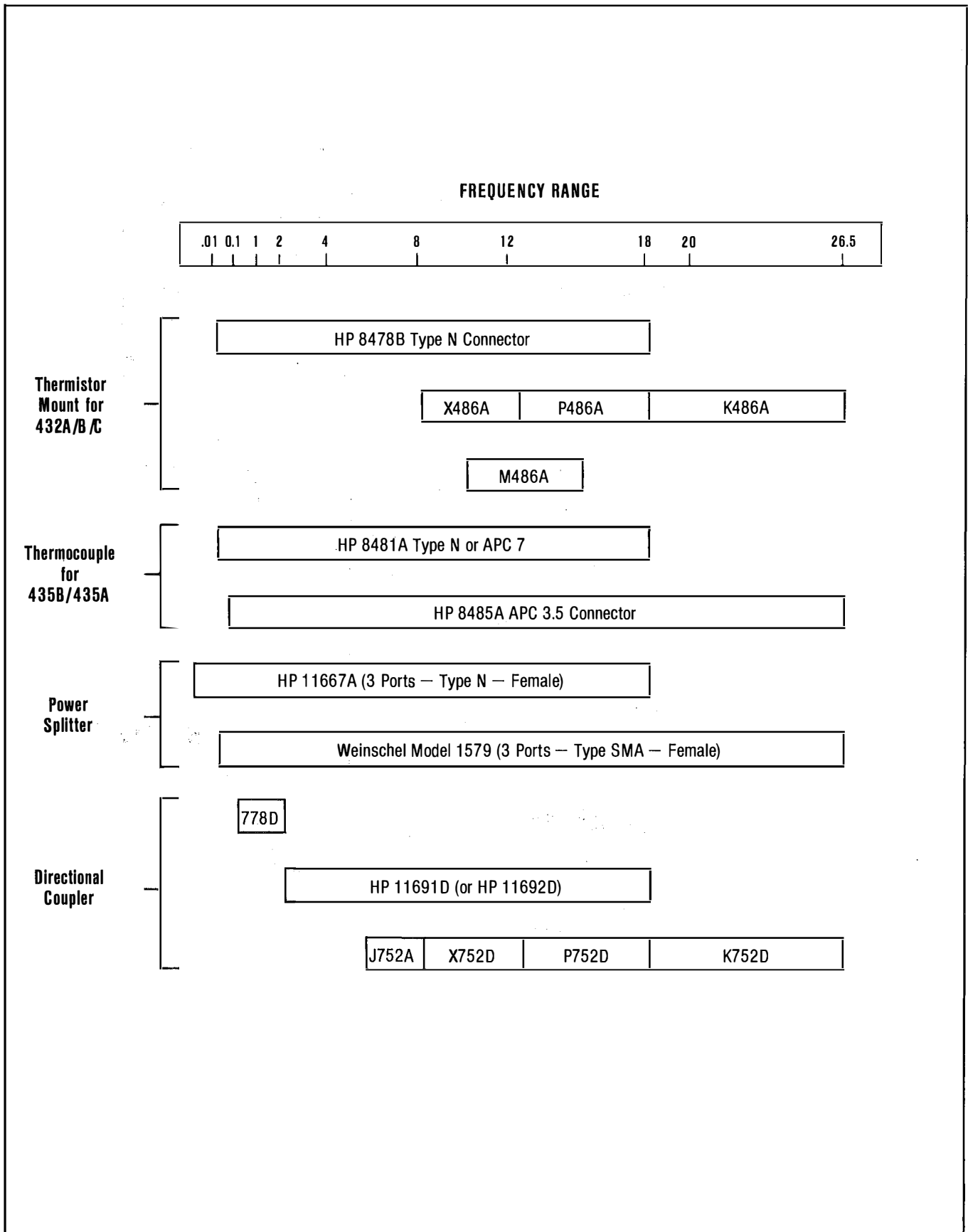

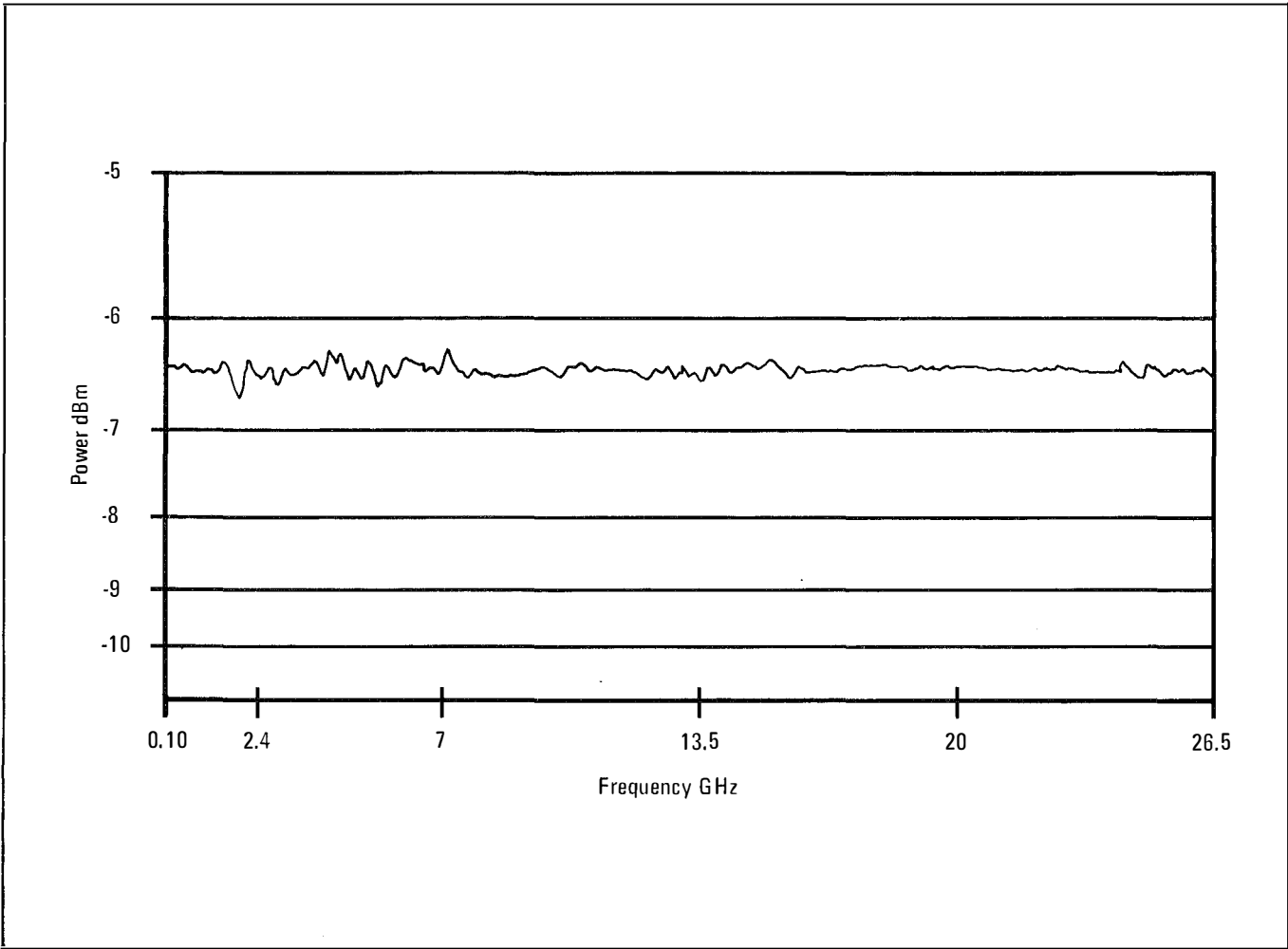

Figure 3. Typical Power Leveling Plot



For more information, call your local HP Sales Office or nearest Regional Office: **Eastern** (201) 265-5000; **Midwestern** (312) 255-9800; **Southern** (404) 955-1500; **Western** (213) 970-7500; **Canadian** (416) 678-9430. Ask the operator for instrument sales. Or write Hewlett-Packard, 1501 Page Mill Road, Palo Alto, CA 94304. In **Europe**: Hewlett-Packard S.A., 7, rue du Bois-du-Lan, P.O. Box, CH 1217 Meyrin 2, Geneva, Switzerland. In **Japan**: Yokogawa-Hewlett-Packard Ltd., 29-21, Takaido-Higashi 3-chome, Sugiyama-ku, Tokyo 168.

HP Part Number 08340-90041

Printed in U.S.A.

Using the HP 8340A Synthesized Sweeper with X-Y Recorders

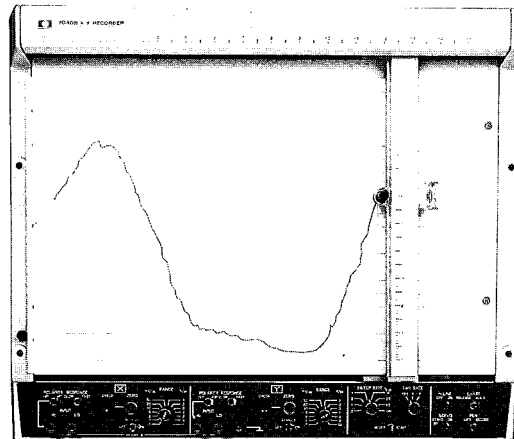

X-Y RECORDERS

The HP 8340A is equipped with outputs to control currently existing HP X-Y analog recorders, which are listed below in Table 1. The 8340A must be placed in the **SINGLE SWEEP** mode when used with an X-Y recorder. Various control lines must also be interconnected; these are described below and a typical setup is also shown in Figure 1.

X-Input: The X-input to the recorder is generally the SWEEP OUTPUT of the 8340A, which is supplied by a BNC connector on both the front and rear panel of the 8340A.

Y-Input: The source of the Y-axis voltage to the recorder depends on the equipment being used in the measurement setup. If the 8755S Frequency Response Test Set is being used, the Y-input would be AUX A for channel 1 and AUX B for channel 2. For 8410B/C systems, the 8412A/B display provides amplitude and phase outputs to the

recorder Y-input via the AMPTD and PHASE BNC connectors, respectively. If the HP 436A Power Meter is used, its RECORDER OUTPUT BNC connector should be used.

Care should be taken to allow the recorder enough time to respond to fine-grain variations in the Y-axis voltage. Recommended 8340A sweep times for each X-Y recorder are given in Table 1.

Pen Lift: The PEN LIFT control line is assigned to a pin on the remote control connector of the recorder, as shown in Table 1. (For a complete listing of all pin assignments on the remote control connector, refer to the Operating and Service Manual of the recorder being used.) The PEN LIFT control line is connected to the PEN LIFT OUTPUT BNC connector on the rear panel of the 8340A. PEN LIFT OUTPUT is operable only if the 8340A sweep time has been set to a value greater than 5 sec.



Table 1. HP X-Y Recorders

| XY Recorder | Mute Function | Mute Function Pin Number | PEN LIFT Pin Number | Ground Pin Number | Recommended Sweep Times |
|-------------|---------------|--|---------------------|--------------------------|-------------------------|
| 7010B | Std. | A2J2 pin 4 A3J2 pin 4 | 3 | A2J2 pin 6 A3J2 pin 6 | ≥20 sec. |
| | Option 002 | A4J5 pin L A4J5 pin R | | A4J5 pin K A4J5 pin P | |
| 7015B | Std. | A4J5 pin L A4J5 pin R | 3 | A4J5 pin K A4J5 pin P | ≥20 sec. |
| 7035B | N/A | N/A | 18 | 6 | ≥20 sec. |
| 7004B | N/A | N/A | 18 | 6 | ≥10 sec. |
| 7034A | N/A | N/A | 18 | 6 | ≥10 sec. |
| 7040A | Std. | Refer to Section III of the Recorder's Operating and Service Manual. | | | ≥10 sec. |
| 7041A | Option 040 | X=pin 5 Y=pin 6 | 1 | 3 | |
| 7044B | Std. | 4 | 1 | 20 | >10 sec. |
| 7045B | Std. | 4 | 1 | 20 | >10 sec. |
| 7046B | Std. | 4 | 34 | 19 | >10 sec. |
| 7047A | Std. | 4 | 1 | 20 | >10 sec. |

Recorder (Servo) Mute: When the 8340A is swept over multiple bands, the RF is momentarily turned off at the band switchpoints. To prevent this from causing negative spikes on the X-Y recorder trace, the recorder's servo motor can be muted during the band crossing. The MUTE OUTPUT BNC connector on the rear panel of the 8340A performs this function, and must be connected to both the recorder's X and Y MUTE inputs, the locations of which are shown in Table 1.

As Table 1 also shows, some HP X-Y recorders do not have a MUTE function. When using one of these recorders, the negative spikes at band switchpoints can still be prevented by pressing **SHIFT LINE** on the 8340A front panel. This activates a function which generates a pen lift signal at each band crossing, thus avoiding the spikes. This function is operable only if the 8340A sweep time has been set to a value greater than 5 sec. Once activated, the function is turned off by pressing **SHIFT LINE** again. No change in the pen

lift connections is required to implement this function.

The **SHIFT LINE** function may also be remotely programmed via HP-IB. The programming codes are as follows:

- SHT21 Enable PEN LIFT during band crossing
- SHT20 Disable PEN LIFT during band crossing

As Figure 1 shows, the **SHIFT LINE** function may be used as a substitute for the MUTE function even on those X-Y recorders that do have MUTE capability.

Figure 2 shows a plot of internally leveled output power from the 8340A vs. frequency. The plot was generated on an HP 7045B X-Y recorder. The output power from the 8340A was monitored with an HP 8485A Power Sensor and HP 436A Power Meter, whose RECORDER OUTPUT provided the Y-axis input to the 7045B.

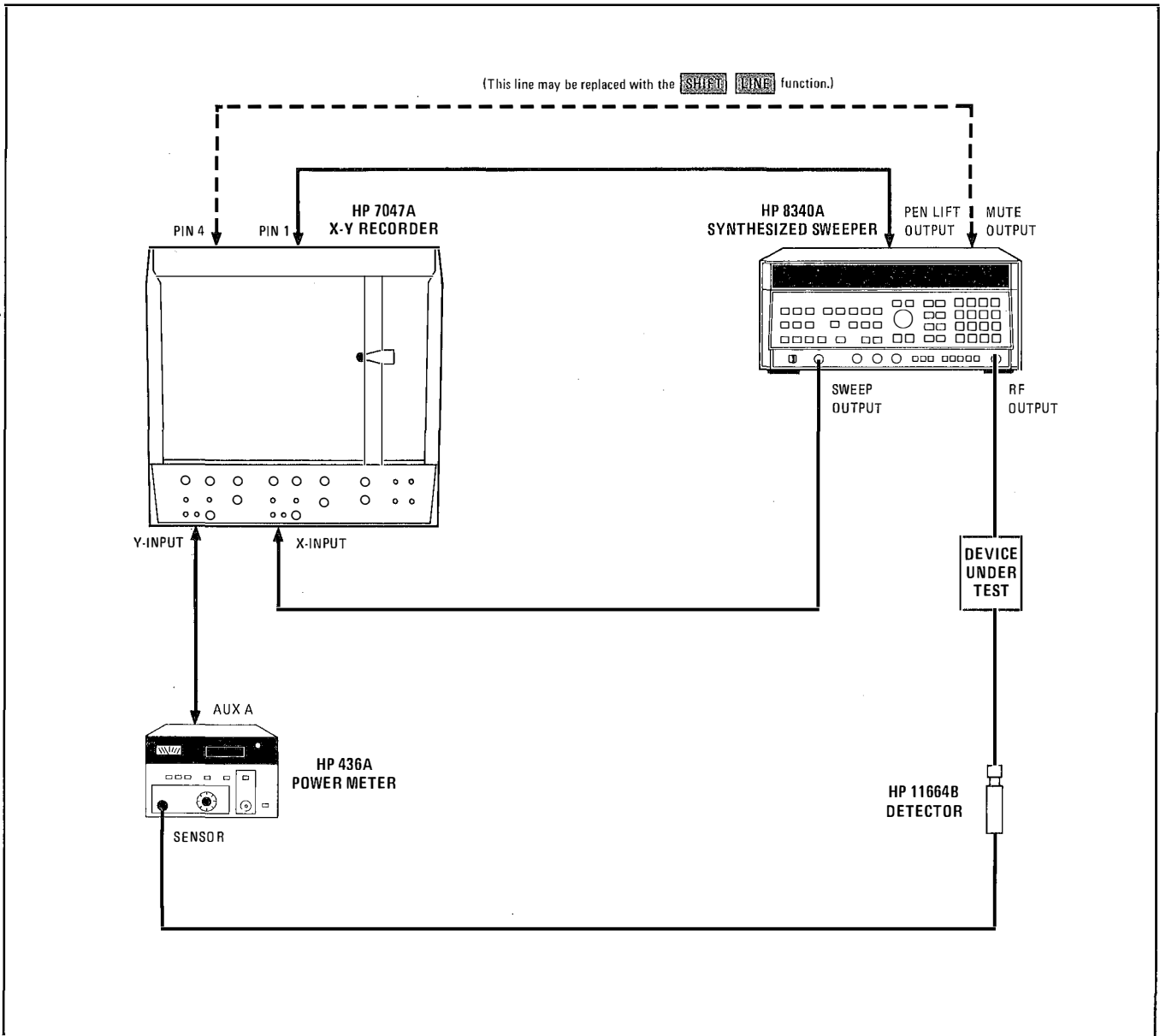

Figure 1. Typical X-Y Recorder Equipment Setup

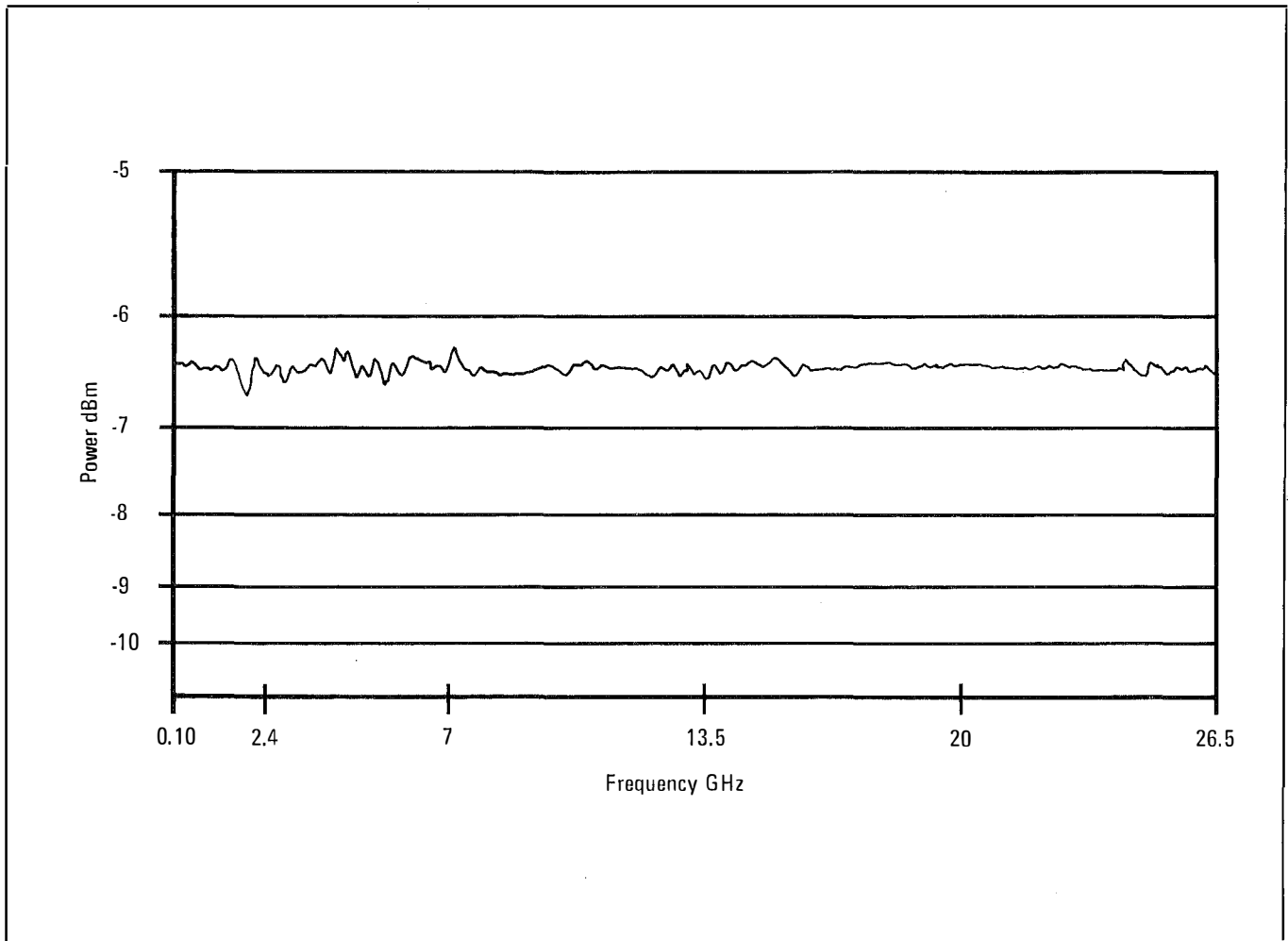

Figure 2. Typical Power Leveling Plot



For more information, call your local HP Sales Office or nearest Regional Office: **Eastern** (201) 265-5000; **Midwestern** (312) 255-9800; **Southern** (404) 955-1500; **Western** (213) 970-7500; **Canadian** (416) 678-9430. Ask the operator for instrument sales. Or write Hewlett-Packard, 1501 Page Mill Road, Palo Alto, CA 94304. In Europe: Hewlett-Packard S.A., 7, rue du Bois-du-Lan, P.O. Box, CH 1217 Mèyrin 2, Geneva, Switzerland. In Japan: Yokogawa-Hewlett-Packard Ltd., 29-21, Takaldo-Higashi 3-chome, Suginami-ku, Tokyo 168.

HP Part Number 08340-90042

Printed in U.S.A.

Using the HP 8340A Synthesized Sweeper with the HP 8410B/C Network Analyzer

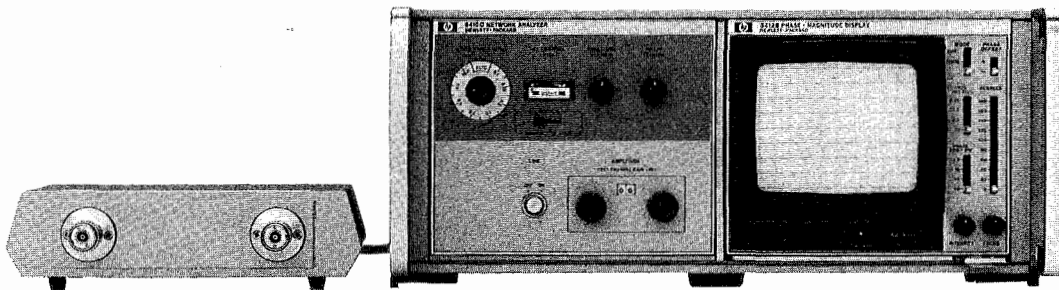

8410B/C NETWORK ANALYZER

The HP 8340A is compatible with the 8410B/C Network Analyzer systems and accessories. The Source Control Cable (HP P/N 08410-60146) synchronizes the two instruments to provide continuous multi-octave coaxial magnitude and phase measurement capability from 110 MHz to 18 GHz with 65 dB dynamic range. The frequency markers can be displayed in polar format as intensity dots (Z-axis).

Waveguide measurements between 18 and 26.5 GHz can be made with the K8747A Reflection/Transmission Test Unit which is designed for use with the 8410B/C. This test system utilizes two 8340A's, one as a local oscillator and the other to sweep the desired frequency range. If desired, any source covering 18 to 26.5 GHz may be substituted as the L.O.

See Figure 1 for an example measurement setup using the 8410B/C with the 8340A.

The 8410B/C **FREQ RANGE** should be set to AUTO. In addition, the sweep time on the 8340A should be slow enough and/or sweep range narrow enough to ensure phase locking of the 8410B/C receiver over the entire sweep range.

Notes on connections:

- 1 V/GHz output of the 8340A provides a frequency reference (FREQ REF) to the 8410B/C so that it may synchronize with the sweep.
- The 8410B/C display units (8412B, 8414B) require that the NEG BLANK from the 8340A be used as the blanking signal.
- Z-AXIS BLANK/MKRS (from the 8340A line) contains the Z axis markers. This line connects to the MARKERS input on the 8414B Polar Display and to the Z AXIS input on the 8412B Phase-Magnitude Display.

- SWEEP OUTPUT outputs a 0 to +10 volt signal in proportion to the swept or CW frequency output. 0 V corresponds to the lower frequency sweep limit; +10 V to the upper. Swept RF output causes a ramp voltage out; CW output causes a dc voltage out. This connection is necessary only when using the 8412B Phase-Magnitude Display.

- 8340A-8410B/C SOURCE CONTROL CABLE. Provides "handshake" lines for synchronization between the 8340A and 8410B/C (HP Part No. 08410-60146).

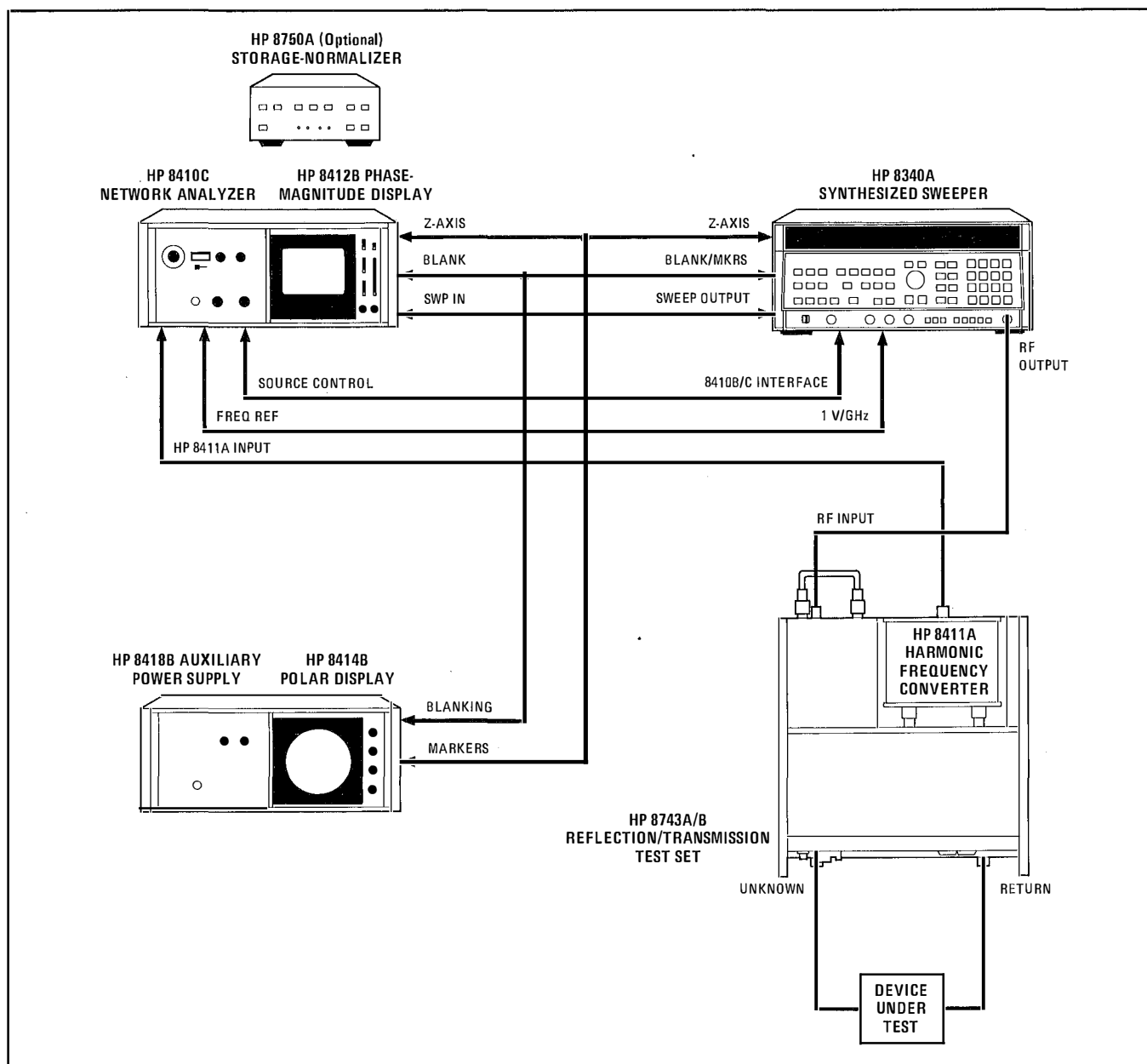

Figure 1. HP 8340A Connections to HP 8410C



For more information, call your local HP Sales Office or nearest Regional Office: Eastern (201) 265-5000; Midwestern (312) 255-9800; Southern (404) 955-1500; Western (213) 970-7500; Canadian (416) 678-9430. Ask the operator for Instrument sales. Or write Hewlett-Packard, 1501 Page Mill Road, Palo Alto, CA 94304. In Europe: Hewlett-Packard S.A., 7, rue du Bois-du-Lan, P.O. Box, CH 1217 Meyrin 2, Geneva, Switzerland. In Japan: Yokogawa-Hewlett-Packard Ltd., 29-21, Takaido-Higashi 3-chome, Suginami-ku, Tokyo 168.

HP Part Number 08340-90043

Printed in U.S.A.

Using the HP 8340A Synthesized Sweeper with the HP 8755 Frequency Response Test Set

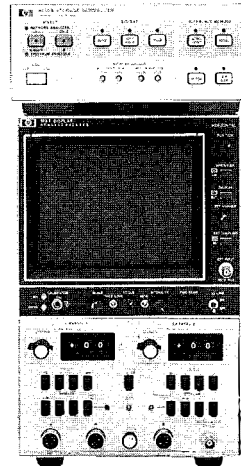
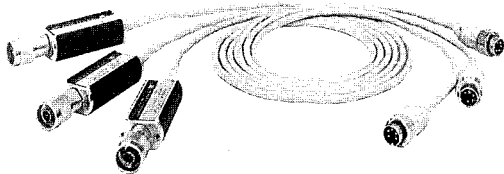

8755S FREQUENCY RESPONSE TEST SET

The 8755S consists of:

- 8755C Swept Amplitude Analyzer
- 182T Display
- 11664A Detectors (3 each)
- 8750A Storage-Normalizer

The 8755S is used for scalar transmission and reflection measurements requiring up to 60 dB of dynamic range and for absolute power measurement from -50 dBm to $+10$ dBm. The 11664A Detectors supplied with the standard 8755S permit operation from 10 MHz to 18 GHz; operation from 10 MHz to 26.5 GHz may be obtained by using the 8755S Option 005, which substitutes for the 11664A Detectors, three 11664B Detectors which have a frequency range of 10 MHz to 26.5 GHz.

The 8340A has the following features to permit maximum utility with the 8755S Frequency Response Test Set:

RF Square-wave Modulation. The 8755C utilizes an AC detection scheme wherein the RF is modulated by a 27.8 KHz square wave. This detection scheme provides excellent stability with time and temperature and allows rejection of unwanted signals that are not modulated. Although the RF can be modulated by an external modulator such as the HP 11665B, this is unnecessary when using the 8340A. All that is required is to connect the MODULATOR DRIVE from the 8755C to the PULSE MODULATION input on the 8340A, and then press **PULSE**.

"Alternate" Function. The **ALT** function of the 8340A allows two different front panel settings to be alternated. For example, the front panel setting and the setting stored in a memory register location n ($n=1,\dots,9$) can be selected for alternate

sweeps. The Alternate Function will not work properly with the 8755A or 8755B. See Figure 1 for a sweep display of the **ALT** function when used to view a bandpass response at different resolutions and offsets. Also see Figure 2 for an example of how an alternate sweep is set up.

Marker Δ The **MKR Δ** function is useful when using alternate sweep in overlapping different sweep widths. The overlapping portion of one of the sweeps can have an increased intensity. The 8750A Storage-Normalizer will need to be in **BYPASS** mode to view Z-axis modulation on the 182T Display.

Power Sweep. The RF output power may be ramped up by using the POWER SWEEP function. See Figure 3 for a gain compression display using power sweep.

Save and Recall. These functions allow the storage and recall of nine complete instrument settings.

Figure 2 outlines the general procedure used in making a scalar transmission and reflection measurement and also shows how to set up an alternate sweep display. The 11666A Reflectometer Bridge is used in this example, but of course other signal separation devices, such as the

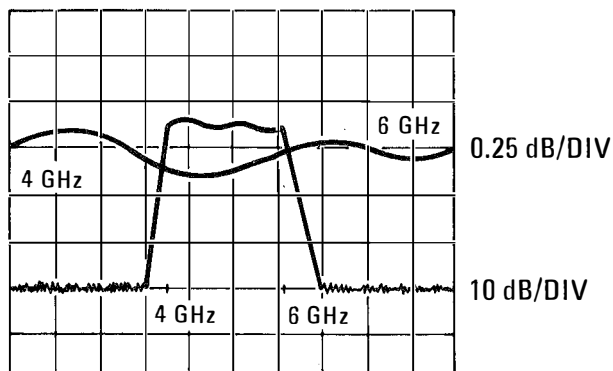

Figure 1. Alternate Sweep Function Display

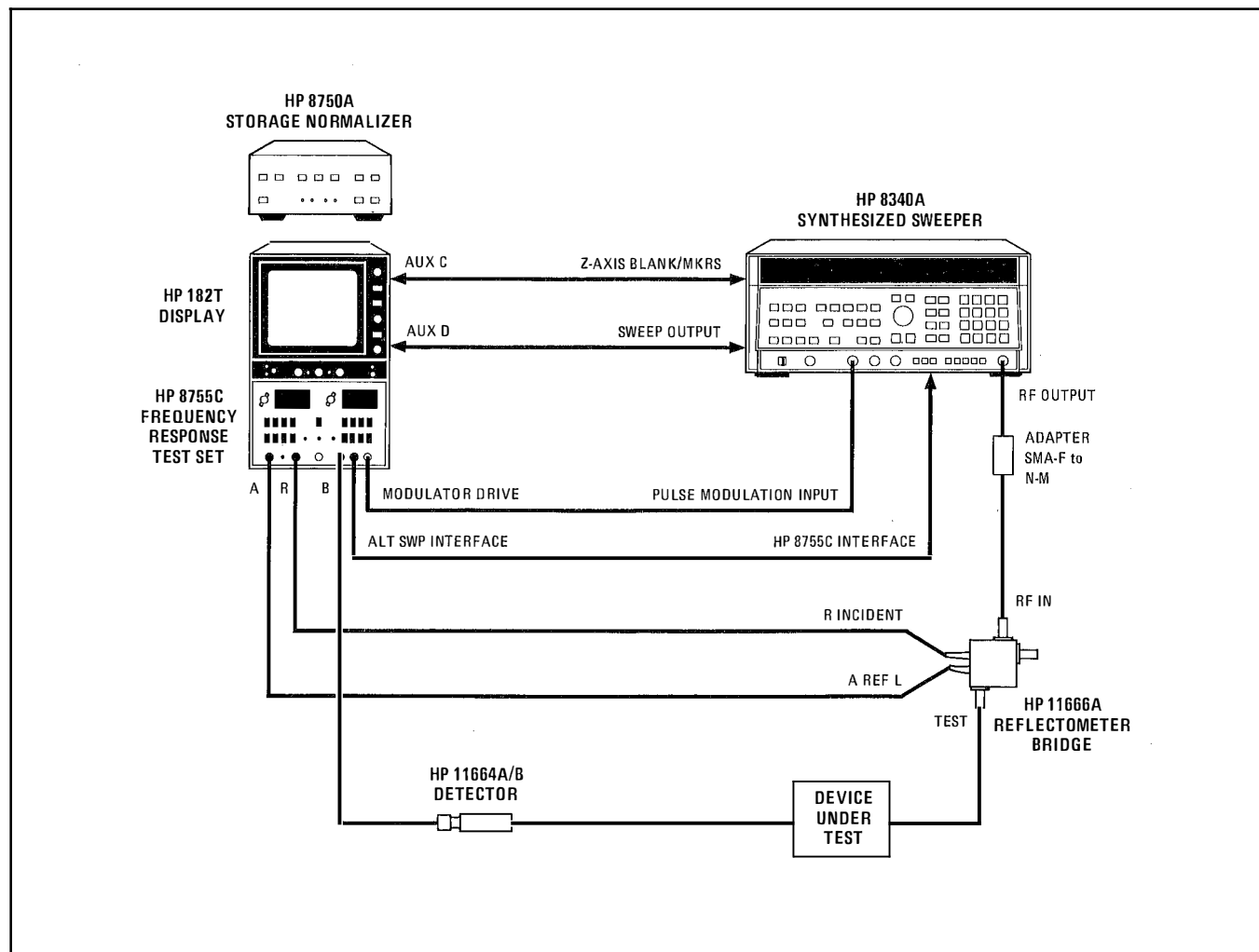

Figure 2. Scalar Transmission and Reflection Measurement

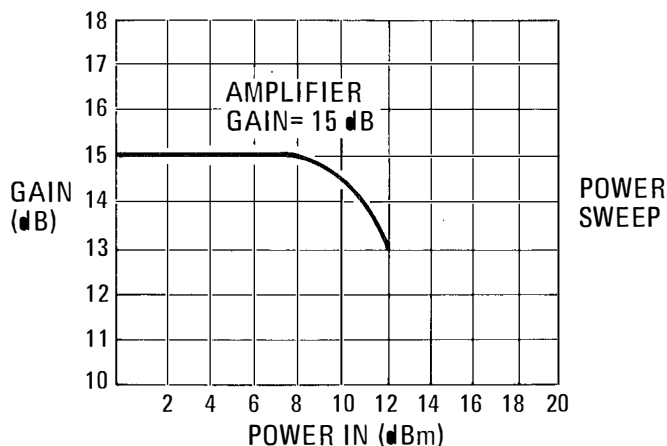

Figure 3. Gain Compression Display

11692D Dual-Directional Coupler, may be substituted. To keep the following procedure brief the 8750A will not be used (switched to **BYPASS**) in the procedure. When using the 8750A with the 8340A Synthesized Sweeper:

- Intensity markers are changed to amplitude markers. In **MKRA** mode they appear as a level shift over the **MKRA** range.
- If an 8755 channel is switched off the trace goes to the reference line (bottom of CRT).

Example:

1. Connect the equipment as shown. Initially, the 8340A should be set by pressing **INSTR PRESET** to set the front panel instrument state and **PULSE** to enable the square wave modulation. Notes on connections:

- Either the front or rear panel SWEEP OUTPUT may be used.

- When in **ALT** mode both channels 1 and 2 (on 8755C) must be on and receiving inputs.

2. Turn off channel 1 on the 8755C by simultaneously releasing all of the channel 1 display pushbuttons. Set the 8340A controls as desired. On channel 2 of the 8755C set the function, dB/DIV and Offset desired for viewing the current sweep setting.
3. Set the 8340A controls as desired then store the current 8340A sweep setting in any available memory location. Then turn off channel 2 by releasing its display pushbuttons.
4. Turn on channel 1 of the 8755C and set the function, dB/DIV and Offset as desired. Set 8340A controls as desired.
5. Turn on channel 2. Press **ALT** and the 8340A will alternate between the two settings on successive sweeps.

Channel 1 now displays the response due to the current front panel setting while channel 2 displays the response to the setting stored in memory location n. (If it is desired to alternate with a memory location other than the one just stored, press the number of that location on the 8340A numeric keypad.) The front panel controls of the 8340A are enabled and the current sweep setting may be altered if desired.



For more information, call your local HP Sales Office or nearest Regional Office: **Eastern** (201) 265-5000; **Midwestern** (312) 255-9800; **Southern** (404) 955-1500; **Western** (213) 970-7500; **Canadian** (416) 678-9430. Ask the operator for Instrument sales. Or write Hewlett-Packard, 1501 Page Mill Road, Palo Alto, CA 94304. In **Europe**: Hewlett-Packard S.A., 7, rue du Bois-du-Lan, P.O. Box, CH 1217 Meyrin 2, Geneva, Switzerland. In **Japan**: Yokogawa-Hewlett-Packard Ltd., 29-21, Takaide-Higashi 3-chome, Suginami-ku, Tokyo 168.

HP Part Number 08340-90044

Printed in U.S.A.

INCREASING THE FREQUENCY SWITCHING SPEED ON THE HP 8340A SYNTHESIZED SWEEPER

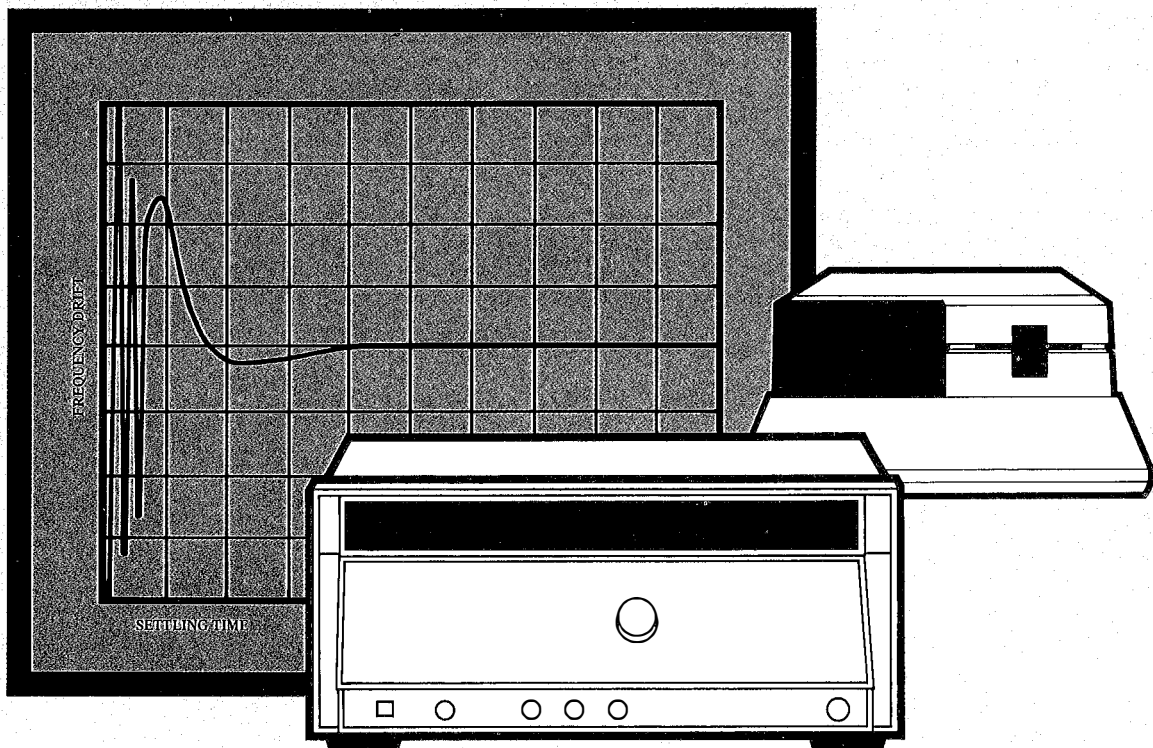

INTRODUCTION

The increased need in automatic test systems for performance characterization of complex equipment requires fast measurement capability and repeatability. In order to provide dynamic test conditions for these systems, the test source must often settle to a new frequency within a few milliseconds.

The HP 8340A Synthesized Sweeper, for example, specifies its frequency switching time to be less than 50 ms across its broad 10 MHz to 26.5 GHz frequency range. However, if greater switching speed is necessary, one can utilize a few existing HP-IB (Hewlett-Packard Interface Bus) commands and programming techniques to achieve up to four times the specified speed.

This product note addresses the 8340A Synthesized Sweeper's definition of specified switching time, and explains the techniques available to improve its switching time, with sample programs written for the HP 200 series (9816A, 9826A, 9836A) controllers.

WHAT IS SWITCHING TIME?

The HP 8340A Synthesized Sweeper's switching time is defined to be the time between programming two frequencies via HP-IB not including the HP-IB character processing times. The total switching time consists of three overlapping components: processor time, lock time, and settling time. The processor time is the time the 8340A takes to program the hardware to a given frequency. The lock time is defined as the time required for the 8340A to tune and phase lock to the new frequency. Once the lock has occurred, there is still a finite phase error in the phase-locked loops to be settled to a steady state. The time it takes for the 8340A to settle to within a given resolution of the final output frequency is called the settling time. In the 8340A, the processor time and the settling time are constant. However, the lock time depends on the size of the frequency change, and the value of the 8340A output frequency. The specified switching time of the 8340A is the worst case time, and it is measured using the worst case step size and the **UP** and **DN** commands. The 8340A's typical frequency switching time is measured at 45 ms.

For efficient use of system time, one should make sure there are no extraneous carriage returns or line feeds after an instruction so that the interface bus will be released to process other instrument (e.g. HP 8566A Spectrum Analyzer) commands while the 8340A is busy. The use of ";" after an instruction suppresses both the carriage return and the line feed which are normally output to the 8340A after the last terminator.

The following sample program shows the use of **UP** commands and ";":

```
10 OUTPUT 719; "IP PM1 CW"; F; "GZ";...Preset 8340A. Turn on pulse modulation. Set the 8340A to CW mode.
20 OUTPUT 719; "SF"; S; "KZ";.....Program the step size.
30 OUTPUT 719; "CW";.....Reactivate CW mode.
40 FOR I=1 TO 100
50 OUTPUT 719; "UP";.....Loop to step CW frequency.
60 NEXT I
70 END
```

COMMANDS THAT IMPROVE SWITCHING TIME

One can improve the 8340A switching time by using a few HP-IB only commands that are implemented in the 8340A.

"IF"

The **IF** command increments the frequency by the specified step size. This command performs the same function as the **UP** command, however, when the 8340A receives an **IF** command it does not update the frequency displayed in the ENTRY DISPLAY (as does the **UP**), thus saving time. This command is functional in the normal mode or the Fixed Points mode (the **SN** command) of the Manual Sweep or in the normal mode of CW operation. (In the Fixed Points mode of Manual Sweep using the **SN** command, one can specify the number of steps desired between the given start and stop frequencies. The minimum and maximum number of these steps are 10 and 1000, respectively.)

The most significant advantage of the **IF** command is that it reduces typical switching time to 25 ms. The disadvantages are that the **IF** command cannot be used to cause random step sizes and that it will not update the ENTRY DISPLAY. However, for most applications, as in automatic test systems, discrete steps are more desirable. In addition, if the 8340A display was active it would be changing too fast to be readable.

The following sample programs show how the **IF** command can be used to increment a frequency by the specified step size in both the Manual Sweep and the CW modes.

The Normal Mode of Manual Sweep:

```

10 OUTPUT 719;"IP PM1 FA";A;"GZ FB";B;"GZ!....Preset 8340A.Turn on pulse modulation.Set start/stop frequency.
20 OUTPUT 719; "SF"; S; "KZ".....Program the step size.
30 OUTPUT 719; "S3"; A; "GZ".....Set the 8340A in Manual Sweep mode.
40 FOR I=1 TO 100
50 OUTPUT 719; "IF"; .....Loop to step frequency.
60 NEXT I
70 END

```

The Fixed Points Mode of Manual Sweep:

Delete line 30 and modify lines 20 and 40 to,

```

20 OUTPUT 719; "SN"; N.....Set the 8340A in Fixed Points Manual Sweep mode and specify number of steps desired.
40 FOR I=1 TO N

```

The Normal Mode of CW:

Modify lines 10-30 to,

```

10 OUTPUT 719; "IP PM1 CW"; F; "GZ!.....Preset 8340. Turn on pulse modulation. Set the 8340A in CW mode.
20 OUTPUT 719; "SF"; S; "KZ".....Program the Step size.
30 OUTPUT 719; "CW".....Reactivate CW mode.

```

"TRIGGER 719"

The command **TRIGGER 719** (where 719 is the HP-IB address of the 8340A), triggers the 8340A to increment to a new frequency by the specified step size. This command is functional in either the normal or the Fixed Points mode (the **SN** command) of the Manual Sweep, or the normal or Fast Phase-lock mode (the **FP** command) of CW operation (For more information on the **FP** command refer to the section on **FP** that follows.) The advantages of the **TRIGGER 719** command are typical switching time of 25 ms in the Fixed Points Manual Sweep mode, and less than 25 ms to be within approximately 1 kHz of the final frequency in the Fast Phase Lock mode.

The following sample programs show how the **TRIGGER 719** command is used in both the Fixed Points mode of Manual Sweep and the Fast Phase Lock mode of CW operation.

The Fixed Points Mode of Manual Sweep:

```

10 OUTPUT 719;"IP PM1 FA";A;"GZ FB";B;"GZ!....Preset 8340A.Turn on pulse modulation.Set start/stop frequency.
20 OUTPUT 719; "SN"; N.....Set the 8340A in Fixed Points Manual Sweep mode and specify number of steps desired.
30 FOR I=1 TO N
40 TRIGGER 719; .....Loop to step frequency.
50 NEXT I
60 END

```

The Fast Phase Lock Mode of CW:

```

10 OUTPUT 719; "IP PM1 CW".....Preset 8340A. Turn on pulse modulation. Activate CW mode.
20 OUTPUT 719; "SF"; S; "KZ".....Program the Step size.
30 OUTPUT 719; "FP2.3E9!.....Activate the Fast Phase-lock mode and set the start frequency.
40 WAIT 0.016.....Program a WAIT time of 16 ms.
50 FOR I = 1 TO 100
60 TRIGGER 719
70 WAIT 0.016 .....Loop to step frequency including a WAIT time of 16 ms per step.
80 NEXT I
90 END

```

"FP"

The previously mentioned **FP** or Fast Phase-Lock command is functional only in the CW mode. Fast Phase-lock, is used when the fastest possible frequency transition is necessary between CW frequencies. **FP** can be used for fast transitions between steps in a stepped CW sweep, or it can be used when the CW frequencies must be rapidly changed to any value in the 10 MHz to 26.5 GHz frequency span of the HP 8340A.

FP achieves rapid frequency transition by limiting some of the normal HP 8340A features: the plotter control functions are disabled, the 0-10 volt sweep ramp is frozen, and the HP 8340A does not wait for a complete locking of the phase lock loop oscillators before releasing the HP-IB handshake. The **FP** code must have a numerical suffix (14 characters maximum) in Hz units, without any terminator code (ASCII LF, normally sent by the computer, is the only allowable terminator), that sets the starting frequency. Leading spaces and terminations (e.g. **HZ** or ",") are ignored. Avoid using a ";" after a numeric entry when using the **FP** command as it suppresses both the Carriage Return and the Line Feed output by a controller. For example, one can program a frequency of 2.3 GHz as follows:

(1) OUTPUT 719; "FP2.3E9"

(2) OUTPUT 719; "FP2300000000"

Variables can be used to represent the frequency after an **FP** command as follows:

(3) OUTPUT 719; "FP";A

However, the same limitations (i.e. frequencies in units of hertz, and 14 characters limitation) as above applies. A format or an image statement in the program may be used to assure the correct representation of the frequency.

When the 8340A receives a **FP** command, it processes the characters and numbers in less than 6 ms and then releases the HP-IB handshake. Thus, the hardware settling time (Lock time + Settling time) will have to be programmed by the user via a **WAIT** statement to guarantee a phase locked frequency. For example, if you program a random step size and cover the total range of the 8340A, a **WAIT** time of 16 ms will typically be sufficient to guarantee phase-locked frequencies. However, if other components of the measurement system (e.t. the HP 8566A Spectrum Analyzer) are programmed in parallel to the 8340A, programming a **WAIT** statement may not be necessary, since the process time of another instrument may allow enough time for the 8340A to reach a synthesized frequency.

The worst-case **WAIT** time of 16 ms covers random step sizes. However, when an application calls for discrete step sizes of less than 1 GHz, the **WAIT** times can be reduced. Some 8340A's were characterized to determine the hardware settling times (**WAIT** times) needed for the frequency to settle within 1 kHz of its final value for various frequency step sizes. The results are shown in TABLE 1 below. For instance, if the user does not cross a band switchpoint and takes 200 MHz steps, the hardware settling time is typically 5 ms, which, when added to the 6 ms of processor time, gives a total typical switching time of 12 ms.

| FREQUENCY STEP SIZE | FREQUENCY SPAN | TYPICAL HARDWARE SETTLING TIMES (OR WAIT TIMES) | TYPICAL TOTAL SWITCHING TIMES (TO BE WITHIN 1 kHz OF FINAL FREQUENCY) |
|---------------------|---|---|---|
| 1 GHz | Within bands ¹ (without crossing bandswitch points) | 10 ms | 16 ms |
| 500 MHz | | 12 ms | 18 ms |
| 200 MHz | | 6 ms | 12 ms |
| 100 MHz | | 11 ms | 17 ms |
| 10 MHz | 190 MHz and within bands ¹ | 5 ms | 11 ms |
| 5 MHz | | 9 ms | 15 ms |
| 2 MHz | | 8 ms | 14 ms |
| 1 MHz | | 5 ms | 11 ms |
| <1 MHz | | <5 ms | <11 ms |
| Random Step Size | Within the whole range of 8340A 0.01 to 26.5 GHz | 16 ms | 22 ms |

TABLE 1. Typical Step Sizes and Hardware Settling Times or **WAIT** Times.

¹ Bands are:
 0.01 to <2.3 GHz
 2.3 to <7.0 GHz
 7.0 to <13.5 GHz
 13.5 to <20.0 GHz
 20.0 to <26.5 GHz

SUMMARY

The HP 8340A is both a high performance broadband synthesizer and a broadband sweeper, and is thus a valuable component of automatic test systems. Its broadband analog sweep capability can be used for faster and more thorough characterization than is possible from a digitally stepped sweep. If, however, point to point information is needed, the 8340A's frequency accuracy and programmability, combined with the improved switching speed techniques described in this note, will provide a fast and repeatable stimulus.

For easy reference, the following table (TABLE 2) summarizes the different techniques and resulting switching times.

| | | CW ¹ | | MANUAL SWEEP ¹ | |
|----------------------------|----------------|---|--|---|--|
| STEP SIZE | COMMANDS | NORMAL MODE (frequency specified in any format) | FAST PHASE-LOCK MODE (frequency specified in exponents or hertz format) | NORMAL MODE (frequency specified in any format) | FIXED POINTS MODE (specify number of steps desired) |
| RANDOM STEP SIZE | | OUTPUT 719;"CW";F;"GZ" Typically 45 ms | OUTPUT 719;"CW" OUTPUT 719;"FP";F;"HZ" WAIT 16 ¹ Typically 22 ms | OUTPUT 719;"S3";F;"GZ" Typically 45 ms | N/A |
| SEQUENTIAL STEP SIZE | UP & DN | OUTPUT 719;"CW";F;"GZ" OUTPUT 719;"SF";S;"GZ" OUTPUT 719;"CW" FOR/NEXT loop to increment frequency Typically 45 ms | N/A | OUTPUT 719;"FA";A;"GZ" OUTPUT 719;"FB";B;"GZ" OUTPUT 719;"SF";S;"GZ"; Output 719;"S3";A;"GZ" FOR/NEXT loop to increment frequency Typically 35 ms | N/A |
| | IF | OUTPUT 719;"CW";F;"GZ" OUTPUT 719;"SF";S;"GZ" OUTPUT 719;"CW" FOR/NEXT loop to increment frequency Typically 25 ms | N/A | OUTPUT 719;"FA";A;"GZ" OUTPUT 719;"FB";B;"GZ" OUTPUT 719;"SF";S;"GZ" OUTPUT 719;"S3";A;"GZ" FOR/NEXT loop to increment frequency Typically 25 ms | OUTPUT 719;"FA";A;"GZ" OUTPUT 719;"FB";B;"GZ" OUTPUT 719;"SN";N (where 10<N<1000) FOR/NEXT loop to implement frequency Typically 25 ms |
| | TRIGGER 719 | OUTPUT 719;"CW";F;"GZ" OUTPUT 719;"SF";S;"GZ" OUTPUT 719;"CW" FOR/NEXT loop to increment frequency Typically 25 ms | OUTPUT 719;"CW SF";S;"GZ" OUTPUT 719;"FP";A WAIT X ¹ (where X is time in milliseconds) FOR/NEXT loop to increment frequency including a WAIT time of X milliseconds Typically <22 ms | OUTPUT 719;"FA";A;"GZ" OUTPUT 719;"FB";B;"GZ" OUTPUT 719;"SF";S;"GZ" OUTPUT 719;"S3";A;"GZ" FOR/NEXT loop to increment frequency Typically 25 ms | OUTPUT 719;"FA";A;"GZ" OUTPUT 719;"FB";B;"GZ" OUTPUT 719;"SN";N (where 10<N<1000) FOR/NEXT loop to increment frequency Typically 25 ms |

TABLE 2. Comparison of Commands and Resulting Switching Times

¹ For complete information on the various commands and programming refer to the respective sections.

HP 8340A PRODUCT NOTES

Contact the nearest Hewlett-Packard Sales and Service Office for other Product Notes. A list of available Product Notes is shown below:

| Product Note | Title | HP Part Number |
|-------------------------------|--|----------------|
| 8340A-2 8340A-3 8340A-4 | Not Assigned Not Assigned Not Assigned | |
| 8340A-5 | <i>60 GHz FREQUENCY COVERAGE USING THE HP 8340A SYNTHESIZED SWEEPER AND THE WJ 1204-4X FREQUENCY EXTENDER</i> | 5952-9346 |
| 8340A-6 | <i>REDUCED HARMONIC DISTORTION USING THE INTEGRA TMF-1800H TRACKING FILTER WITH THE HP 8340A SYNTHESIZED SWEEPER</i> | 5952-9343 |
| 8340A-7 | <i>MICROWAVE NOISE FIGURE MEASUREMENTS USING THE HP 8340A SYNTHESIZED SWEEPER WITH THE HP 8970A NOISE FIGURE METER</i> | 5953-8879 |

Introductory Operating Guide for the HP 8340A Synthesized Sweeper with the HP 9826A or 9836A Desktop Computer (BASIC)

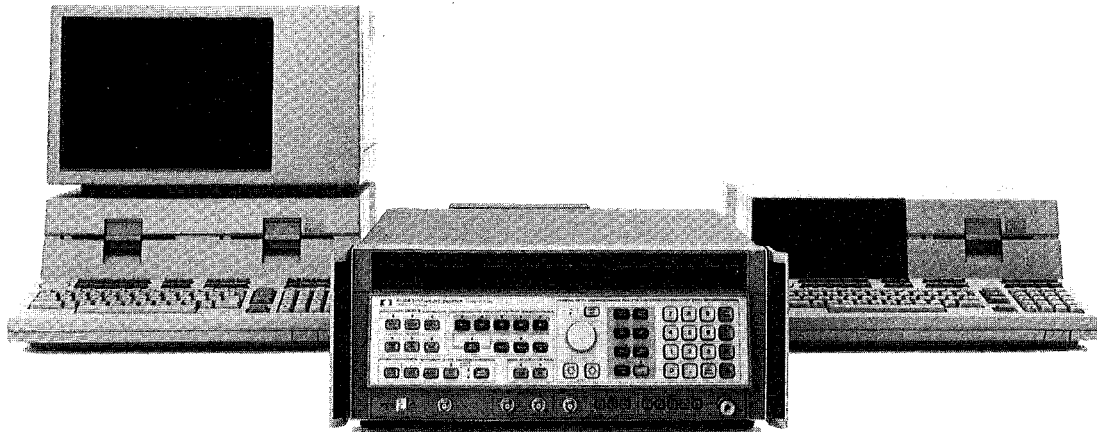

INTRODUCTION

This programming note is a guide to the remote operation of the HP 8340A Synthesized Sweeper. Included in this guide are the system connections for remote operation and sample programs that demonstrate the capabilities of the 8340A and provide a starting point to those who want to create programs tailored to their specific measurement needs.

The HP 8340A is a fully programmable Synthesized Sweeper compatible with the Hewlett Packard Interface Bus (HP-IB). When used with a controller such as the HP 9826A or 9836A, complete control of the synthesized CW frequency, sweep mode, frequency limits, frequency markers, power level, modulation, and all other front panel controls can be achieved.

The HP 9826A and 9836A Desktop Computers are ideal instrument controllers based on a 16-bit microprocessor featuring multilanguage capability, with mini disc mass storage, Alpha and Graphic

mode Display, built-in standard HP-IB interface, and expandable memory and interfacing capability. This note demonstrates the HP-IB control of the 8340A via the enhanced BASIC 2.0 Programming language system. For clarity, only the 9826A is referenced in the sample program explanations, although all the sample programs will run on the 9836A as well.

REFERENCE INFORMATION

For further information on the HP Interface Bus, the following should prove helpful:

Tutorial Description of the Hewlett-Packard Interface Bus (HP Lit. No. 5952-0156)

Condensed Description of the Hewlett Packard Interface Bus (HP Lit. No. 59401-90030)

Complete reference information on the HP 8340A Synthesized Sweeper can be found in the 8340A Operating and Service Manual (HP Part No. 08340-90020) and 8340A Quick Reference Guide (HP Part No. 5952-9338).

For information on operating the 9826A and 9836A, the following references are available:

9826A Operating Manual (HP Part No. 09826-90000)

BASIC Language Reference (HP Part No. 09826-90055)

BASIC Programming Techniques (HP Part No. 09826-90010)

BASIC Interfacing Techniques (HP Part No. 09826-90020)

EQUIPMENT REQUIRED

To perform all the example programs as described in this programming note, you will need the following equipment and accessories:

HP 8340A Synthesized Sweeper

HP 9826A Desktop Computer with:

Opt. 011 (or 711) BASIC programming language:

Opt. 011 Computer with ROM-based BASIC 2.0 Language System with 42K bytes of user memory

Opt. 711 Computer with RAM-based BASIC 2.0 Language System with 42K bytes of user memory

For extended memory:

98245A 64K Byte External RAM Memory Board

98256A 256K Byte External RAM Memory Board

For hard copy output:

A Thermal Graphics Printer which is compatible with the HP 9826A such as the HP 2673A

Two HP-IB Cables (HP 10631A or HP 10833A)

NOTE

The following equipment is not required for the programs to function but rather for a visual display of the 8340A functions.

HP 8755S Frequency Response Test Set with:

HP 8755C Swept Amplitude Analyzer

HP 180TR or 182T Display Unit

HP 11664B Detector

Three 120 centimeter BNC cables (HP 11170C variety)

NOTE

The HP 8755S may be replaced by any appropriate Oscilloscope with Crystal/Schottky Detector, Attenuator, and BNC cabling.

HP 8566A Spectrum Analyzer with 10631A (or 10833A) HP-IB Cable

HP 3312A Function Generator (or equivalent)

HP 8011A Pulse Generator (or equivalent)

Any test device within the frequency range of the 8340A (10 MHz to 26.5 GHz)

SETUP

Figure 1 shows the system connection. All that is required is to:

1. Connect the 24-pin HP-IB connector of the built-in HP-IB interface of the 9826A to the printer and the 8340A.

Refer to O/S Manuals for more detail on interconnects.



Do not attempt to mate black metric threaded screws on one connector with silver English threaded nuts on another connector, or vice versa, as damage may result. (A metric conversion kit which will convert one cable and one or two instruments to metric hardware is available by ordering HP Part No. 5060-0138.)

2. Following the instructions in the BASIC Operating Manual for the HP 9826A, load the BASIC language system, if required. (Option 711)
3. The HP-IB select code is assumed to be preset to 7. This programming note assumes the HP-IB address of the 2673A Graphics Printer is 01.
4. All programs within this guide expect the 8340A HP-IB address to be decimal 19. The 8340A HP-IB address is factory preset to decimal 19.

To find the present HP-IB address use the front panel "Set HP-IB Address" function by pressing:



The ENTRY DISPLAY will indicate the present decimal address. If the number displayed is not 19, it may be reset to 19 by pressing:



The non volatile memory of the HP 8340A will maintain this HP-IB address until another address is entered.

CHECK OUT

If your computer has a soft-loaded operating system and power has been turned off, then follow instructions to reload the system. When the message "BASIC READY" reappears, turn on the rest of the equipment.

The 8340A should undergo a turn-on self test consisting of the red LED Numeric displays being blanked and all indicator LED's on. The 8340A sweep controls are then set to the instrument preset state: START/STOP sweep internally leveled over the entire frequency range, fastest sweep time, and 0 dBm output power. If the 8340A fails the turn-on self test then either the red LED's next to INSTR PRESET Key will be on, or the FAULT annunciator will come on. Check section 8 or the 8340A Operating and Service manual for error message explanations and diagnostics.

To verify that the HP-IB connections and interface are functional:

1. Press **SHIFT PAUSE** to reset the 9826A
2. Type in **SCRATCH EXECUTE** to clear any previous programs in memory
3. Press **EDIT EXECUTE** then type in the following program:

```

10  IHPIB TEST
20  S0=719
30  ABORT 7
40  CLEAR S0
50  PRINT "9826A is ACTIVE controller"
60  REMOTE S0
70  PRINT "8340A is in REMOTE MODE"
80  END

```

When several instruments are connected to the HP Interface Bus, an **ABORT** command abruptly terminates all bus activity and resets all devices on the bus to turn-on states and the 9826A recovers the active control of the bus. The **CLEAR** command sets all (or only selected) instruments to a pre-defined device-dependent state. The **REMOTE** command is used to put all (or selected) instruments into the remote mode.

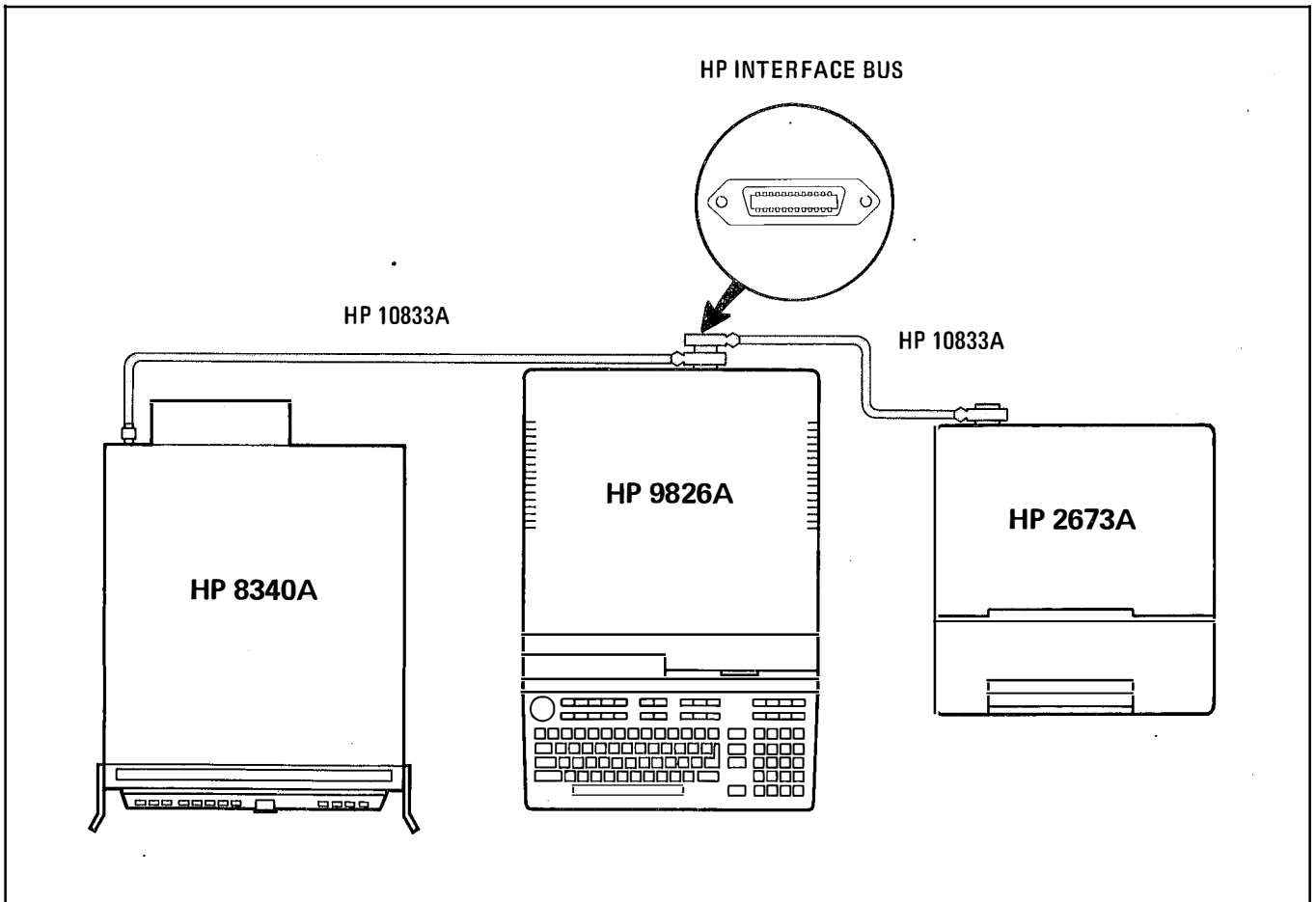

Figure 1. Connection System

Run the program and verify the REMOTE light is lit on 8340A. If it is not, verify the 8340A address is set to 19 and the interface cable properly connected.

If the 9826A display indicates an error message, it is possible the program was entered incorrectly. If the 9826A accepts the REMOTE statement but the 8340A REMOTE light does not turn on, perform the operational checks as outlined in the respective Operating and Service Manuals to find the defective device.

All the 8340A functions available through the front panel keys are programmable via HP-IB. When the 8340A is in REMOTE mode, all the front panel keys are disabled except the LOCAL key. But, when the **LOCAL LOCKOUT** command is set on the bus, even the LOCAL key is disabled. The **LOCAL** command, executed from the 9826A, is then the only way to return all (or selected) instruments to front panel control.

Continue the above program and type in the following commands:

```
80 PAUSE
90 REMOTE S0
100 LOCAL LOCKOUT 7
110 PRINT "LOCAL LOCKOUT MODE"
120 PAUSE
130 LOCAL 7
140 PRINT "RETURN TO LOCAL"
150 PAUSE
160 OUTPUT S0;"IP"
170 END
```

To verify and investigate the different remote modes do the following:

1. Press **SHIFT PAUSE** to reset the 9826A
2. Press **INSTR PRESET** on the 8340A
3. Press **SHIFT CLR LN** and **RUN** on the 9826A
4. With the 9826A displaying "ACTIVE CONTROLLER" and "REMOTE" messages, verify that the 8340A REMOTE light is lit. From the front panel, attempt to change the start frequency and verify that this is impossible. Verify that the INSTRUMENT PRESET key and all other keys except LOCAL are disabled. Now press the **LOCAL** key and verify that the 8340A REMOTE light is off and that you can modify any of the sweep functions.
5. Press **CONTINUE** on the 9826A. With the 9826A displaying "LOCAL LOCKOUT MODE", verify that the 8340A REMOTE light is again lit. Again attempt to change the start frequency and perform an instrument preset. Verify that this is impossible. Now press the 8340A **LOCAL** key and verify that still no action is taken.

6. Press **CONTINUE** on the 9826A. With the 9826A displaying "RETURN TO LOCAL", verify that the 8340A REMOTE light is off. Also verify that all sweep functions now can be modified via the front panel controls.
7. Press **CONTINUE** on the 9826A. Verify that the 8340A has undergone an Instrument Preset and the REMOTE light is on. The Output (**OUTPUT 719**) statement does two things: one, it performs a **REMOTE 719**, and second, it passes instructions to the 8340A.

Note that the 8340A LOCAL key produces the same result as programming **LOCAL 719** or **LOCAL 7**. Be careful as the latter command places all instruments on the HP-IB in the local state as opposed to just the 8340A alone.

PROGRAMMING EXAMPLES

The following sample programs show the various ways of controlling the 8340A. In remote control situations the 8340A Synthesized Sweeper interacts with the system HP-IB controller in two basic ways:

1. "Listen Mode": The 8340A listens to the control commands instructing it to modify the present instrument state. This commands the 8340A to do a specific event just like setting a front panel function.
2. "Talk Mode": The 8340A informs the controller of the present instrument state with a numeric value or a string of characters. This allows the user to interrogate or learn any 8340A function.

Each programming example is structured using the following format:

1. A general description of the functions exercised.
2. The program listing.
3. Instructions for operating the system and explanation of the program.

EXAMPLE PROGRAM 1: Setting Up A Typical Sweep

In swept operation, the synthesized sweeper is programmed for the proper sweep frequency range, sweep time, power level, and marker frequencies for a test measurement. This program sets up the 8340A for a general purpose situation using several dedicated format and image statements.

To program any function on the 8340A, the controller must pass specific program codes and data to the instrument. The statement that allows this is the **OUTPUT** statement. The alphanumeric data string of the output statement can be a concatenation of character strings and/or variables. The data

can be specific codes, free field formatted data, or reference a specific **IMAGE** statement. For example, to program the Start Frequency (**FA**), one program code sequence is **FA**, followed by the frequency in GHz, then **GZ**. If the frequency is to be 1.234 GHz, then the string "**FA1.234GZ**" will suffice. However, if the frequency were to change then a variable F could indicate the frequency in GHz and the program string could be "**FA**"; **F**; "**GZ**". Finally, using an image statement will allow a specific number of digits to be passed, thereby avoiding any unexpected round off errors.

PROGRAM 1

```

10 !SETTING UP A SWEEP
20 S0=719
30 PRINT CHR$(12)
40 OUTPUT S0;"IPFA1.234GZFB5.678GZ"
50 PRINT "START FREQUENCY is 1.234 GHz"
60 PRINT "STOP FREQUENCY is 5.678 GHz"
70 DISP "ENTER SWEEP TIME in msec";
80 INPUT T
90 PRINT "SWEEP TIME is",T,"msec"
100 OUTPUT S0;"ST";T;"MS"
110 IMAGE "PL",SDD,"DB"
120 DISP "ENTER POWER LEVEL in dBm";
130 INPUT P
140 PRINT "POWER LEVEL is ",P,"dBm"
150 OUTPUT S0 USING 110;P
160 PAUSE
170 IMAGE "M1",K,"GZ"
180 OUTPUT S0 USING 170;3.5
190 OUTPUT S0;"M24666E6"
200 PRINT "MARKER No 1 is 3.5 GHz"
210 PRINT "MARKER No 2 is 4.666 GHz"
220 PRINT "SETTING COMPLETED"
230 END

```

PROGRAM 1 EXPLANATION AND OPERATION

The equipment set-up is the same as in the check-out description. Reset the HP 9826A, scratch its memory and enter the above program. Then perform the following:

1. Run the program and observe that the 9826A CRT display is cleared (line 30) by printing a Form Feed. Then the 8340A is set to START/STOP Frequency mode. This first programming sequence is the most common format used to program the 8340A: "**FA1.234GZFB5.678GZ**" is sent on the same line after the **OUTPUT S0** command. Then the values of Start and Stop frequencies are printed on the CRT display (lines 40 to 60).
2. When a parameter is subject to change, the value is entered from the controller keyboard into a variable. In this example, the sweep time is entered in milliseconds into the variable T. Then, the Sweep Time is programmed using the following format: "**ST**";**T**;"**MS**" and the value of Sweep Time is printed on CRT display. (lines 70 to 100).

3. When a parameter is to be entered in a specific format, an image statement is used to select the number of digits and sign to be passed. The free format to program POWER LEVEL on the HP 8340A allows two digits after the decimal point. In this example, the **IMAGE** statement changes this format, suppressing the two digits after the decimal point. The S causes the output of a leading plus or minus and indicates the sign of a number. The two D's cause the two digits of the number to be output. The value entered by the user is displayed on the CRT, then rounded by the 9826A to the nearest "dB" resolution, and then sent to the 8340A. The value printed can be compared to the value in the 8340A ENTRY DISPLAY (lines 110 to 150).

To enter another value of Power Level, type in **CONT 110** then **EXECUTE** and enter the new value of POWER LEVEL.

4. Press **CONTINUE** and Marker 1 is set to a fixed value using an **IMAGE** Statement (line 160 and 170). Then Marker 2 is set to 4666 MHz using a full data format: the value of the frequency is sent in Hz and it is not necessary to terminate the programming sequence with a units terminator. Hertz is here a default terminator. Then the Marker 1 and 2 values are displayed on the CRT (line 190 and 200).

When a typical sweep like the above example is setup, the complete front panel state may be saved for later use in non-volatile memories called Registers 1 through 9.

This can be done remotely as a part of the above program by pressing **EDIT EXECUTE** on 9826A, and adding the following lines:

```

230 PAUSE
240 OUTPUT S0;"SV1IP"
250 PRINT "SETTING STORED IN REGISTER 1"
260 WAIT 3
270 OUTPUT S0;"RC1"
280 END

```

Then press **RUN**, and enter new values for the typical sweep. When "SETTING COMPLETED" is displayed, press **CONTINUE**. The 9826A will save in Register 1 the previous sweep and then put the 8340A in the Instrument Preset state. After a 3 second delay, Register 1 is recalled and the saved state is reactivated.

EXAMPLE PROGRAM 2: A Stepped CW Sweep

Many automatic measurement systems make measurements at a sequence of CW test frequencies instead of digitizing an analog sweep in the frequency range of interest. If swept, the measure-

ment data-taking machine would need to sample the RF signal at a very fast rate to maintain accurate frequency information. Stepped CW Sweeps also offer the advantage of maintaining the synthesized frequency features of the 8340A at each frequency. A stepped CW Sweep can be accomplished in several ways.

1. Program sequential CW test frequencies.
2. Program the frequency sweep range then enable the manual sweep mode. Perform a stepped manual sweep by repetitively programming the step up/increment function.
3. Program the CW frequency to the start frequency, the Step Size to an appropriate value, then repetitively program the step up/increment function.

Considering the speed of programming the above approaches, methods 2 and 3 are most efficient time wise. This program illustrates a stepped sweep using these approaches.

PROGRAM 2

```

10  ISTEPPED CW
20  S0=717
30  PRINT CHR$(12)
40  OUTPUT S0;"IPPM1"
50  DISP "ENTER START FREQUENCY in GHz";
60  INPUT A
70  DISP "ENTER STOP FREQUENCY in GHz";
80  INPUT B
90  IF A>B THEN GOTO 50
100 DISP "ENTER STEP SIZE in GHz";
110 INPUT S
120 IF S>B-A THEN 90
130 D=(B-A)/S
140 INTEGER D
150 PRINT "THE 8340A IS STEPPED SWEEPING"
160 PRINT "... TO STOP THE SWEEP:PRESS PAUSE"
170 OUTPUT S0;"SF";B;"GZCW";A;"GZ"
180 FOR I=1 TO D
190 OUTPUT S0;"UP"
200 NEXT I
210 GOTO 170
220 END

```

PROGRAM 2 EXPLANATION:

Lines

- 10-40:** The 8340A address is entered in S0 and the 9826A CRT display is cleared. Then the 8340A is put in a predefined state via instrument Preset and pulse modulation is turned on to enable the 27.8 kHz Square Wave Amplitude modulation from the 8755C.
- 50-90:** Start frequency is entered in variable A and stop frequency in variable B. If A>B other values must be entered.

100-120: Frequency step size is entered in variable S and compared to the full sweep. If $S > B-A$, another step value must be entered.

130-140: The number of steps is calculated and assigned to D and made to be an integer.

150-170: Programs frequency step size and the CW frequency is set to the start value. Then information for the user is displayed on the CRT.

180-210: The 8340A frequency is incremented from start to stop frequency. When the stop frequency is reached, the 8340A is programmed back to the start frequency and the cycle begins again.

Set up the equipment as shown in figure 2 by adding the 8755C, the 180TR or 182T, the 11664B, and a test device like a 4 to 6 GHz Bandpass Filter. It is important that the two rear panel connections from the 8340A to the 8755C/182T and modulation drive connections are made for a proper CRT display. For the example measurement set the following front panel controls:

On the 8755C:

- Channel 1:
 Display OFF
 (press all the display push buttons so that they are all out)
- Channel 2:
 Display B
 dB/DIV 10 dB
 Reference Level -10 dB
 Ref. Level Vernier OFF

On the 182T or 180TR:

- Magnifier X1
 Display INT

Reset the 9826A, scratch the 9826A memory and type in the above program. Then perform the following:

1. Run the program and enter the start frequency. Then press **CONTINUE**, enter the stop frequency, then press **CONTINUE** again.
2. Enter the frequency step size and press **CONTINUE**

The 8340A is now being stepped in frequency between the start and stop frequencies.

The sweep may not cover the full screen; however, this is normal. In CW mode, the 8340A delivers on the sweep output connector a voltage proportional to the frequency value. Thus, if the frequency is 10

MHz, the trace will be at the very left of the analyzer CRT and if the frequency is 26.5 GHz, the trace will be at the very right of the analyzer CRT.

To obtain a full screen sweep on the CRT, the 8340A must be set in Manual Sweep and Start/Stop Frequency modes. The program can be modified to do this by typing in the following lines:

NOTE

The previous program is only modified from line 170 and beyond.

PROGRAM 2 (continued)

```

170 OUTPUT S0;"SF";S;"GZFA";A;"GZFB";B;"GZ"
180 OUTPUT S0;"S3";A;"GZ"
190 FOR I=1 TO D
200 OUTPUT S0;"IF"
210 NEXT I
220 GOTO 180
230 END

```

On line 170, Frequency step size is programmed, then start and stop frequencies are programmed.

On line 180, the 8340A is placed in the manual sweep mode and set to the start frequency.

Then the 8340A Frequency is incremented with the IF function. The operation of this function is the same as UP, but faster. When the 8340A receives an UP command, it is buffered in the ENTRY DISPLAY. When the IF command is received, it does not go through the ENTRY DISPLAY, thus saving time.

Then Run the modified program and verify that the ENTRY DISPLAY is off.

Also note the sweep is now occupying the full screen on the analyzer's CRT.

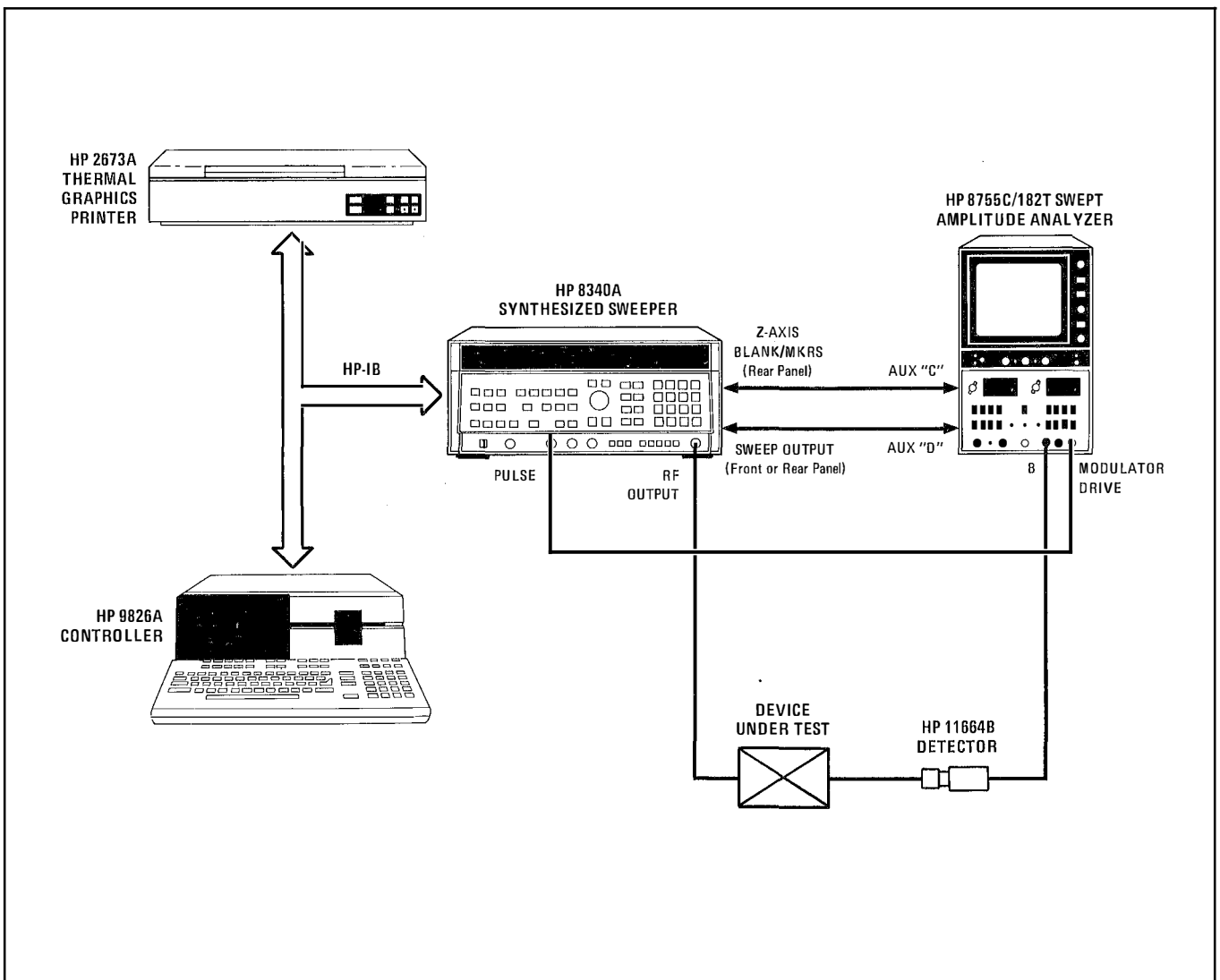

Figure 2. Equipment Setup

EXAMPLE PROGRAM 3: Setting Up A Power Sweep

The 8340A can sweep output power level as well as frequency. The start level of a power sweep is entered using the power level control. The power sweep width (dB/SWP) is entered using the power sweep function. In the coupled mode of operation, the ALC loop and 10 dB step attenuator are automatically coupled. The ALC loop dynamic range covers from -20 dBm to $+20$ dBm and is centered around 0 dBm (figure 3-1a). Note that the power sweep cannot cross an internal attenuator switch point. The maximum power sweep range is thus determined by the difference of the lowest ALC power before the attenuator switch point (-9.95 dBm) and the maximum power available from the ALC loop (figure 3-1b).

However, since the ALC can operate as low as -20 dBm, the power sweep range can be extended by decoupling the ALC loop and output attenuator.

Then the maximum power sweep range is from the bottom of ALC loop dynamic range (-20 dBm) to the maximum power available in the ALC loop (figure 3-1c).

The following program illustrates the two different modes of using power sweep:

PROGRAM 3

```

10 !SETTING POWER SWEEP
20 S0=719
30 PRINT CHR$(12)
40 OUTPUT S0;"IPPM1"
50 OUTPUT S0;"CW5GZPL-19.95DBPS115DBEK"
60 PRINT "PRESS CONTINUE"
70 PAUSE
80 OUTPUT S0;"CW22GZPS110DBEK"
90 PRINT "..PRESS CONTINUE"
100 PRINT " TO EXTEND POWER SWEEP OVER 20 DB"
110 PAUSE
120 OUTPUT S0;"CW5GZPL-20DBSHPS-20DBPS128DBEK"
130 PRINT "...PRESS CONTINUE"
140 PAUSE
150 OUTPUT S0;"CW22GZPS121DBEK"
160 PRINT ".....END"
170 END

```

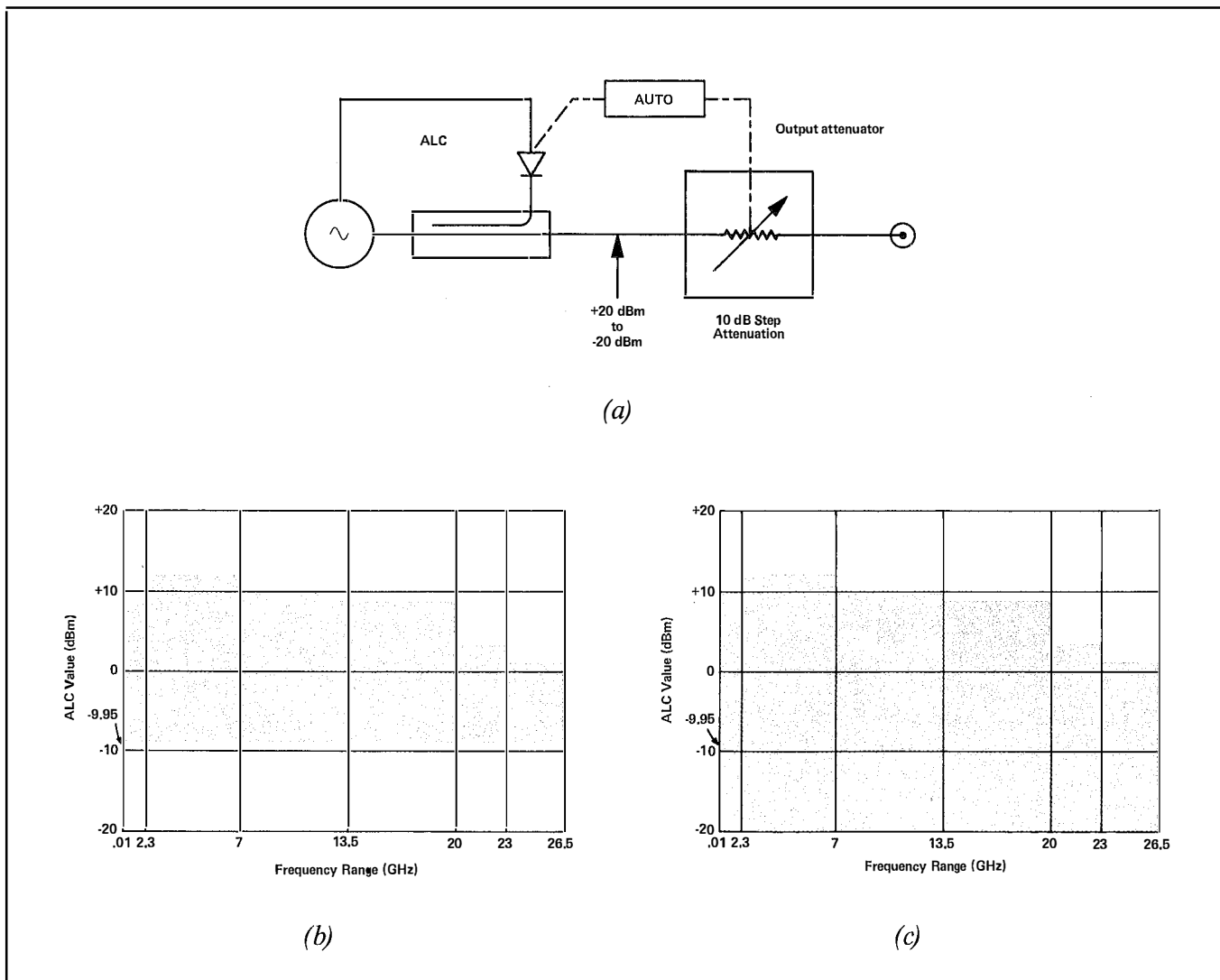

Figure 3. Power Sweep Range

PROGRAM 3 EXPLANATION:

Lines

- 10-40:** The 9826A CRT is cleared, the 8340A is set in a predetermined state, and pulse modulation is activated to enable the 27.8 kHz square wave amplitude modulation from the 8755C.
- 50-70:** Program the CW frequency to 5 GHz, the power level to -19.95 dBm and set the power sweep to 15 dB. Then the knob is enabled for data entries on the last programmed function; in this case, power sweep. Then, the program execution is temporarily stopped.
- 80-110:** With respect to the previous setting, only the frequency is changed and set to 22 GHz, but the power sweep must be programmed again to ensure that the knob will control power sweep data entries.
- 120-140:** Sets CW frequency to 5 GHz, power level to -20 dBm, decouples ALC loop and output attenuator and sets ALC power level to -20 dBm. Then the power sweep is set to 28 dB and the knob is enabled for power sweep entries.
- 150-170:** With respect to the previous setting, the frequency is changed to 22 GHz, and power sweep is set to 21dB. Then the knob is enabled for power sweep data entries.

The equipment setup is the same as in the previous example. Reset the 9826A, scratch the 9826A memory, type in the above program and then run the program and perform the following:

1. The CW frequency is set to 5 GHz, the power level to -19.95 dBm and the power sweep to 15 dB. Since the 8340A is operating in the coupled mode, the output attenuator is set to 10 dB attenuation and the power level is set to -9.95 dBm in the ALC loop to achieve -19.95 dBm output power. Then, the power is swept from -9.95 dBm to $+5.05$ dBm in the ALC loop.

Note the 8340A is still in remote, but the knob on 8340A front panel is enabled to change the power sweep value. Note on the analyzer CRT that power is swept. Extend the power sweep range with knob until power output UNLEVELED light is lit. The ENTRY DISPLAY now reads the typical power sweep range at 5 GHz.

2. The frequency is set to 22 GHz. At this frequency, the maximum specified power level is $+3$ dBm. The ALC loop is set to -9.95 dBm, so the maximum specified power sweep range is 12.95 dB. Extend the power sweep with the knob to reach the typical value.
3. The frequency is then set back to 5 GHz and the power level to -20 dBm, automatically putting in 20 dB attenuation. Then the ALC loop and output attenuator are decoupled by executing **SHIFT PWR SWP**. The ALC loop value can now be adjusted between -20 dBm and $+20$ dBm without causing a change in the attenuator setting. The ALC loop power level is programmed to -20 dBm. Next, the power sweep range is set to the specified value at 5 GHz: 28 dB. Adjust power sweep with the knob to get a typical value.
4. The fourth step of the program changes frequency to 22 GHz and power sweep to the specified power sweep range: 21 dB. Check, using the knob, for the typical power sweep range.

EXAMPLE PROGRAM 4: Modulating the 8340A

The 8340A features both Amplitude Modulation and Pulse Modulation via a modulating signal from an external signal source. Detailed Specifications can be found in the HP 8340A Operating and Service Manual.

The following program describes a typical modulation set-up and automatically displays the modulated signal on the HP 8566A Spectrum Analyzer.

PROGRAM 4

```
10  IMODULATION
20  S0=719
30  S1=718
40  PRINT CHR$(12)
50  OUTPUT S0;"IP"
60  DISP "ENTER FREQUENCY in GHz";
70  INPUT F
80  OUTPUT S0;"CW";F;"GZ"
90  !AM
100 OUTPUT S0;"AM1"
110  A=20
120  GOSUB Spectrum
130  PRINT "PRESS CONTINUE"
140  PAUSE
150  !PM
160  OUTPUT S0;"AM0PM1"
170  A=1500
180  GOSUB Spectrum
190  GOTO 230
200 Spectrum:  OUTPUT S1;"IPCF";F;"GZSP";A;"KZ"
210             LOCAL S1
220             RETURN
230  PRINT "...END"
240  END
```

PROGRAM 4 EXPLANATION:

Lines

- 10-50:** Set 8340A HP-IB address to S0 and 8566A Spectrum Analyzer HP-IB address to S1. Then the 9826A CRT is cleared and 8340A put into its predetermined state via Instrument Preset.
- 60-80:** Allow the operator to enter CW frequency in the variable F. Then program the CW frequency.
- 90-140:** Program Amplitude Modulation on 8340A and put span width information in variable A. Then go to the "SPECTRUM" subroutine for an automatic Frequency Spectrum display of the amplitude modulated signal. Program execution is then temporarily stopped.
- 150-190:** After the user presses CONTINUE, amplitude modulation is turned off and pulse modulation turned on. Span width information is then stored in the variable A and the program proceeds to the "Spectrum" subroutine.
- 200-220:** Programs the 8566A to center frequency and span width, then returns the 8566A to local.
- 230-240:** Print "END" message.

Setup the equipment as shown in figure 4 by connecting the 8340A output to the 8566A Spectrum Analyzer input using an APC 3.5 to Type N adapter. Connect the output of the HP 3312A to the amplitude modulation BNC input connector and connect the 8011A output to the pulse modulation BNC input connector. Connect the 10 MHz REF output of 8340A to the REF input on 8566A. Set the modulation sources as follows:

3312A:
 FUNCTION..... Sine
 RANGE..... 1K
 FREQUENCY..... 5
 OFFSET..... CAL
 AMPLITUDE..... 1 Vp-p

8011A:
 PULSE PERIOD..... 1 ms to 5 ms
 PULSE WIDTH..... 1 μ s to 50 μ s
 AMPLITUDE..... 5V
 OUTPUT MODE..... Internal load

Run the program. Then enter a CW frequency and press **CONTINUE**. The 8566A CRT displays the amplitude modulated signal. The modulating frequency can be changed on 3312A. Change the frequency span with the knob on the 8566A Spectrum Analyzer if necessary.

Next, press **CONTINUE** and the 8566A CRT will display a pulse modulated signal.

The pulse width and pulse repetition frequency may be changed on the 8011A pulse generator. Again, change the frequency span on the 8566A with the knob if necessary.

EXAMPLE PROGRAM 5: Learning An Instrument State

Being able to save a specific instrument state is helpful when it is needed several times in a test or measurement procedure. The user could save the instrument state by manually logging the important sweep parameters (such as frequency range, power level, ALC modes, etc.) then re-inputting them at the appropriate time. A somewhat simpler approach is to save the instrument state in one of the 8340A internal storage registers, then recall it when needed. (See example program 1.) Another solution is to use the Output Learn String function of the 8340A so that the 9826A can learn and then store a data string that describes the present instrument state on a disk or in its internal memory. Once an instrument state is stored or learned, the 8340A can then be restored to that state using the Input Learn String function. The power of these instrument Learn/Teach functions are demonstrated by the following program.

PROGRAM 5

```

10  !LEARN STRING
20  S0=719
30  PRINT CHR$(12)
40  OPTION BASE 1
50  DIM A$(150)
60  OUTPUT S0;"IPPM1"
70  PRINT "CHANGE FRONT PANEL CONFIGURATION"
80  LOCAL S0
90  PAUSE
100 BEEP 1000,.1
110 OUTPUT S0;"DL"
120 ENTER S0 USING "#,123A";A$
130 LOCAL S0
140 PRINT "CHANGE FRONT PANEL CONFIGURATION"
150 PRINT "...AGAIN"
160 PAUSE
170 BEEP 2000,.1
180 OUTPUT S0;"IL"&A$
190 PRINT "...END"
200 END

```

PROGRAM 5 EXPLANATION:

Lines

- 10-30:** Assign S0 to the 8340A address and clear the 9826A CRT.

- 40:** Define the first element of any array to be at index number 1.
- 50:** Set the length of the A\$ string to 150 characters.
- 60-90:** Set the 8340A to a predefined state via instrument preset and enable the pulse modulation for use with the 8755C scalar network analyzer. Then ask the user to change the instrument state and return the 8340A to local control so he may do so.
- 100-110:** Send an audible beep and program the 8340A to output the current instrument settings (the learn string) into the 9826A.
- 120:** Read the learn string into the 9826A using a byte fast handshake transfer of 123 characters ignoring the line feed on the string terminator. Store the 123 character learn string in A\$.

130-160: Return the 8340A to local and ask the user to again change the 8340A front panel state, temporarily halting the program until he does so.

170-190: After sending out the audible beep, input the learn string to the 8340A causing it to return to the state set by the user during lines 60-90 of the program. Then prompt the user that the program is finished.

Setup the equipment as in example 2 using the analyzer's CRT display to verify the sweep settings.

Reset the 9826A, scratch the 9826A memory, then type in the above program. Clear the 9826A CRT display, then run the program. The 8340A will undergo an instrument preset, enable the pulse modulation, then return to local front panel control. Then perform the following:

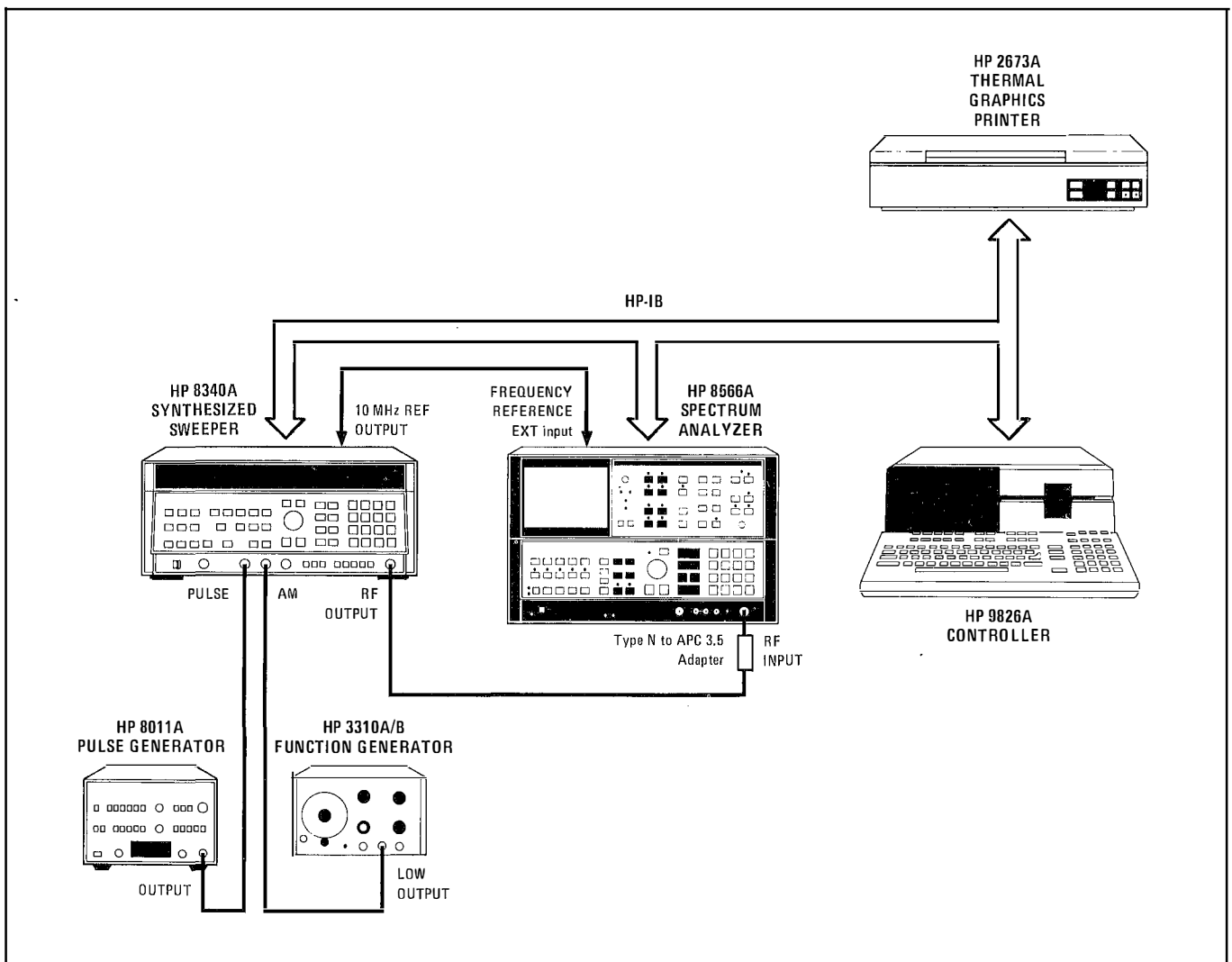

Figure 4. Modulation Setup

1. Adjust the 8340A to a preferred instrument state, then press **CONTINUE** on the 9826A.
2. Turn the 8340A off, press **INSTRUMENT PRESET**, or change the instrument settings in any way desired.
3. Press **CONTINUE** on the 9826A. Verify on the analyzer's CRT display and/or the 8340A front panel that the original instrument state has been restored.

EXAMPLE PROGRAM 6: Interrogating The Present Value Of A Function

While the 8340A Learn String enables the user to save a string of characters that completely defines the present instrument state, the information is densely packed and encoded to save memory space. If the user wishes to determine the actual value of a specific parameter, say the Start Frequency, it would require a tedious process to extract a numeric value from several characters within the Learn String. An easier approach is to use the Output Interrogated Parameter function of the 8340A. With this function the 9826A instructs the 8340A to output the present numeric value of a specified function. Any function that has a numeric value associated with it can be interrogated even if this function is not presently active. The following program demonstrates the capability of the interrogate function. It shows how to get the current value of a parameter whether it has been entered in the 8340A or computed by the 8340A internal processor.

PROGRAM 6

```

10 !OUTPUTS FROM 8340A
20 S0=719
30 PRINT CHR$(12)
40 OUTPUT S0;"IPPM1"
50 !DISP "ADJUST START FREQUENCY WITH KNOB"
60 OUTPUT S0;"FAEK"
70 PAUSE
80 OUTPUT S0;"OA"
90 ENTER S0;A
100 DISP "ADJUST STOP FREQUENCY WITH KNOB"
110 OUTPUT S0;"FBEK"
120 PAUSE
130 !DISP
140 OUTPUT S0;"OA"
150 ENTER S0;B
160 C=(B-A)/2+A
170 OUTPUT S0;"PCF"
180 ENTER S0;D
190 PRINT "CF computed by 9826A is";C/1.E+6;"MHz"
200 PRINT "CF output from 8340A is";D/1.E+6;"MHz"
210 OUTPUT S0;"CW20GZPL15B"
220 !DISP "PRESS CONTINUE TO OUTPUT THE POWER"
230 PAUSE
240 OUTPUT S0;"OR"
250 ENTER S0;P
260 DISP
270 PRINT "POWER LEVEL in ENTRY display is 15 dBm"
280 PRINT "Real Output POWER LEVEL is ";P;"dBm"
290 END

```

PROGRAM 6 EXPLANATION:

Lines

- 10-40:** Assign S0 to the 8340A address. Then clear the 9826A CRT, set the 8340A in the Instrument Preset state and enable the 8340A pulse modulation for use with the 27.8 kHz square wave modulation from the 8755C Scalar Network Analyzer.
- 50-70:** Enable the knob to adjust Start Frequency and temporarily halt the program.
- 80-90:** Program the 8340A to output the numeric value associated with the last active function. (In this case, START FREQUENCY). This value is then entered in the variable A.
- 100-120:** Enable the knob to adjust Stop Frequency and temporarily halt the program.
- 130:** Clear the display line on the 9826A CRT.
- 140-150:** Same as lines 80-90 for Stop Frequency.
- 160:** The 9826A computes Center Frequency from the A and B variables and stores this in the variable C.
- 170-180:** Program the 8340A to output the current value of a specified parameter. In this case, the desired parameter is the CF computed by the internal processor of the 8340A from the Start and Stop frequencies previously entered. This value is then stored in the variable D.
- 190-200:** Display both values of Center Frequency stored in C and D.
- 210-230:** Program CW frequency to 20 GHz and power level to 15 dBm. Then, output a prompt to the user and temporarily halt program execution.
- 240-250:** Program the 8340A to output the real output power. This is done with the OR command, which reads the value shown in the POWER dBm display of the 8340A, which is always the actual power of the signal coming out of the RF connector. The value obtained is assigned to P.
- 260-290:** Display prompts and print the value of power in the ENTRY DISPLAY on the 8340A and the value of power in the POWER dBm display on the 8340A.

The equipment required is the same as in the previous example. Reset the 9826A and scratch the 9826A memory. Now type in the above program and run it. Then perform the following:

1. Adjust the Start frequency value with the knob. Then press **CONTINUE**.
2. Adjust the Stop frequency value with the knob. Then press **CONTINUE**.

NOTE

The resolution of start and stop frequencies will probably be different. This is normal because the frequency resolution changes as the sweep width (ΔF) is changed.

3. Center frequency values are displayed on the 9826A CRT. Then press **CONTINUE**.
4. The CW Frequency is set to 20 GHz and power level to 15 dBm. Since the specified power at this frequency is +3 dBm (figure 3), the power will be unlevelled. The **OR** statement outputs the real output power value which differs from the ENTRY DISPLAY and is shown in the POWER dBm display. The two values are printed on the 9826A CRT.

Another method to quickly transfer parameters which define a typical sweep is to use the Output Coupled Parameter statement **OC**. This statement outputs three values representing:

1. Start Frequency in Hertz
2. Center Frequency in Hertz
3. Sweep Time in Seconds

Modify the above program by typing in the following lines:

PROGRAM 6 (continued)

```

290 DISP "PRESS CONTINUE"
300 PAUSE
310 !OUTPUT COUPLED PARAMETERS
320 OUTPUT SO;"FAPLDBOC"
330 ENTER S0;F,G,H
340 PRINT
350 PRINT "START FREQUENCY is",F/1.E+6,"MHz"
360 PRINT "CENTER FREQUENCY is",G/1.E+6,"MHz"
370 PRINT "SWEEP TIME is",H*1000,"msec"
380 END

```

EXPLANATION:

On line 320, the 8340A is programmed to Output Coupled Parameters.

On line 330, the three parameter values are put in variables F for Start Frequency, G for Center Frequency, and H for Sweep Time.

On lines 350 to 370, parameter values are displayed on the 9826A CRT. Frequencies are displayed in megahertz and sweep time in milliseconds.

Run the modified program and the coupled parameters will be displayed on the 9826A CRT.

EXAMPLE PROGRAM 7: Using Service Requests, Status Bytes, and Request Mask

Certain error conditions of the 8340A can be detected by the 9826A so that corrective action can be taken. A few examples of detectable error conditions are RF power unlevelled, RF unlocked, programming syntax error and power failure. If an error condition exists, the user can instruct the 8340A to request service from the 9826A by initiating a Service Request (SRQ). The 9826A can detect whether an SRQ has taken place on the bus by analyzing bit 1 of its interrupt status register (Register 4 on the 9826A HP-IB interface - see table 1). Two methods are available for analyzing the status of the HP-IB interface of the 9826A. 1) periodically read the interrupt status register (Register 4). 2) enable the bit 1 of the Interrupt Enable Mask (Register 5) to interrupt the program when bit 1 is set. In either case, the user must determine which device on the bus requested service. This can be done using an SPOLL command to sequentially analyze the status byte of each instrument on the bus. By definition of the IEEE-488 bus, the instrument that requested service will have bit 6 of its status byte (REQUEST SERVICE) true. Once it is determined that the 8340A has requested service, the specific error condition(s) is then determined by analyzing the Status Bytes of the 8340A. The 8340A has two Status Bytes, each consisting of 8 bits with each bit indicating the present status of a particular function or condition. See table 2 for a complete description of the conditions associated with each status byte bit. The user can analyze all of the conditions of the status bytes for every SRQ, or more simply, instruct the 8340A to issue an SRQ only if a specific set of error conditions exists. The set of error conditions is determined by a numeric value generated by summing the decimal values of each bit to be checked in the first Status Byte. Its binary equivalent is sent to the 8340A using the Request Mask function (RM) and CHR\$.

The following program demonstrates the capability of the SRQ and the two Status Bytes to detect an error condition. This specific example analyzes an SRQ on an unlevelled power condition, an RF unlocked condition and a front panel service request when the instrument is in local mode.

Table 1. HP-IB Status Registers 4 and 5 of the 9826A Controller

| Status Register 4: Interrupt Status Status Register 5: Interrupt Enable Mask | | | | | | | | |
|---|---------------------------------|------------------------------------|--------------------------------|-----------------------------------|----------------|--------------------------------|---------------------|--------------------------------|
| BIT # | 15 (MSB)¹ | 14 | 13 | 12 | 11 | 10 | 9 | 8 |
| DECIMAL VALUE | 32 768 | 16 364 | 8 192 | 4 096 | 2 048 | 1 024 | 512 | 256 |
| FUNCTION | Active Controller | Parallel Poll Configuration Change | My Talk Address Received | My Listen Address Received | EOI Received | SPAS | Remote/Local Change | Talker/Listener Address Change |
| BIT # | 7 | 6 | 5 | 4 | 3 | 2 | 1 | 0 (LSB)² |
| DECIMAL VALUE | 128 | 64 | 32 | 16 | 8 | 4 | 2 | 1 |
| FUNCTION | Trigger Received | Handshake Error | Unrecognized Universal Command | Secondary Command While Addressed | Clear Received | Unrecognized Addressed Command | SRQ Received | IFC Received |

1. MSB: Most Significant Bit
2. LSB: Least Significant Bit

Table 2. 8340A Status Byte Descriptions

| STATUS BYTE (#1) | | | | | | | | |
|---------------------------|--|-----------------------|---------------------------|---------------------|------------------------------|--|---|------------------------------------|
| BIT # | 7 | 6 | 5 | 4 | 3 | 2 | 1 | 0 |
| DECIMAL VALUE | 128 | 64 | 32 | 16 | 8 | 4 | 2 | 1 |
| FUNCTION | SRQ on New frequencies or Sweep Time in Effect | REQUEST SERVICE (RQS) | SRQ on HP-IB Syntax Error | SRQ on End of Sweep | SRQ on RF Settled | SRQ on Changed in Extended Status Byte | SRQ on Numeric Entry Completed (HP-IB or Front Panel) | SRQ on Any Front Panel Key Pressed |
| EXTENDED STATUS BYTE (#2) | | | | | | | | |
| BIT # | 7 | 6 | 5 | 4 | 3 | 2 | 1 | 0 |
| DECIMAL VALUE | 128 | 64 (L) | 32 (L) | 16 (L) | 8 | 4 | 2 | 1 (L) |
| FUNCTION | Fault Indicator On | RF Unleveled | Power Failure | RF Unlocked | External Freq. Ref. Selected | Oven Cold | Over Modulation | Self Test Failed |

(L): See Note 3.

PROGRAM 7

```
10 !STATUS BYTES
20 S0=719
30 ABORT 7
40 CLEAR S0
50 PRINT CHR$(12)
60 ENABLE INTR 7;2
70 OUTPUT S0;"RM"&CHR$(5)
80 ON INTR 7 GOSUB Statusbyte1
90 OUTPUT S0;"IPCSPMICW15GZT1PL"
100 LOCAL S0
110 DISP "ADJUST POWER LEVEL"
120 GOTO 120
130 Statusbyte1: STATUS 7,4;A
140 B=SPOLL(S0)
150 IF BIT(B,0)=1 THEN PRINT "FRONT PANEL SRQ"
160 IF BIT(B,2)=1 THEN GOSUB Statusbyte2
170 ENABLE INTR 7;2
180 RETURN
190 Statusbyte2: OUTPUT S0;"CSOS"! (SEE NOTE 3)
200 ENTER S0 USING "*",B";E,F
210 IF BIT(F,4)=1 THEN PRINT "RF IS UNLOCKED"
220 IF BIT(F,4)=0 THEN PRINT "RF IS LOCKED"
230 IF BIT(F,6)=1 THEN PRINT "OUTPUT IS UNLEVELED"
240 IF BIT(F,6)=0 THEN PRINT "OUTPUT IS LEVELED"
250 PRINT
260 LOCAL S0
270 RETURN
280 END
```

PROGRAM 7 EXPLANATION

Lines

- 10-20:** Assign the 8340A address in the variable S0.
- 30:** Terminates all Listener or Talker functions of all instruments on the bus.
- 40:** Clears the status bytes of the 8340A.
- 50:** Clears the 9826A CRT display.
- 60:** Enables an interruption on bit 1 (decimal value 2) on the 9826A status register 5.
- 70:** Sets a Request Mask on 8340A on bit 0 (decimal value 1) and 2 (decimal value 4) of the first status byte. The binary equivalent of 5 (decimal values 4+1) is sent using CHR\$.
- 80:** When the 9826A receives an interrupt, the program execution is continued on subroutine "Statusbyte1".
- 90:** Presets the 8340A in a predetermined state and enables the pulse modulation for the 8755C Scalar Network Analyzer. The status bytes are cleared via the CS command. Then the 8340A is programmed to the CW mode and the PL function is activated to allow the knob to control the output power level.
- 100-110:** The 8340A is returned to local and a prompt is displayed on the 9826A CRT.
- 120:** The program execution remains on the same line 120, waiting for an interruption.
- Note that this line can be the beginning of a user program.
- 130:** Reads the current state of the interrupt status register (register 4) on the 9826A and stores its value in the variable A. Normally the variable A would then be examined to see what caused the interrupt, but since line 60 made bit 1 the only bit that could cause an interrupt, this is unnecessary.
- 140:** Reads the current state of the first status byte of the 8340A and, in so doing, clears it. Note that it is unnecessary to examine bit 6 of B to see if the 8340A is the instrument that requested service because the 8340A is the only instrument on the bus in this example.
- 150:** Tests bit 0 of first status byte. Then prints a prompt.
- 160:** Tests bit 2 of first status byte and then sends program execution to continue on to subroutine "Statusbyte2" if necessary.
- 170:** Re-enables an interruption on bit 1 on the 9826A status register 5.
- 180:** Returns to main program execution.
- 190:** Programs the 8340A to output both status bytes. (See Note 3).
- 200:** Fast transfer of the two status bytes, in binary form, into variables E and F.
- 210-240** Test bits 4 and 6 of the extended status byte and print prompts depending on the current state of the tested bit.
- 250-280:** Prints a space on the 9826A CRT, then sends the program execution back to line 170 of the subroutine "Statusbyte1".

Set-up the equipment as shown in figure 5 and use the analyzer's CRT display to verify the settings. Reset the 9826A and scratch its memory. Then type in and run the above program. Then perform the following:

1. The 8340A is set in CW mode at 15 GHz. The FREE RUN trigger is selected, giving a swept CW display on the analyzer's CRT.

2. The 8340A is in local mode but the program is still running. Thus, if any front panel key is pressed, an interruption occurs and the prompt "FRONT PANEL SRQ" is displayed and the program execution goes back on line, waiting for another interrupt. Note the 8340A is still in LOCAL.
3. An "RF UNLOCKED" interrupt may be generated by disconnecting the jumper that supplies the FREQUENCY STANDARD Reference. This jumper is connected between INT and EXT BNC connectors of the frequency standard input/output on the rear panel of the 8340A.
4. An SRQ is also obtained by adjusting the power level with the knob until the power becomes unlevelled. Then an SRQ occurs and an "OUTPUT IS UNLEVELED" prompt is displayed on 9826A CRT. Reduce the power level to return to leveled power and observe another SRQ with an "OUTPUT IS LEVELED" prompt displayed on 9826A CRT.

As bit 2 of the 8340A Status Byte shows, an SRQ occurs when a change in the extended status byte occurs. Thus, an SRQ is detected for a change either from the leveled or from the unlevelled state.

Note that whatever the origin of the SRQ, the current status of both bits 4 and 6 of the extended status byte is displayed.

NOTE 3

When an interruption occurs, this information is sent to the controller. With a priority pre-determined in the software, the controller will

read the Status of the 8340A. Thus, the controller does not respond instantaneously to the Service Request. During this delay, the cause of the SRQ may have disappeared. (See figure 5a.) To avoid having the controller get an SRQ with "no information", on some functions of the extended status byte the bit corresponding to the function requiring the service is latched even if the cause of the SRQ disappears before the controller has read the extended status byte. These functions are: overmodulation (bit 1), RF unlevelled (bit 4), power failure (bit 5) and RF unlevelled (bit 6). Figure 5 shows how this latching works via two examples of output level power variations. In example (a) an SRQ is sent (t1) when the RF output goes "unleveled". But the RF output is back to "leveled" before the controller has read the status of line 3 (bit 6 of the extended status byte). Then the controller reads the latched information and in so doing, clears it (t2) so the user knows that an unlevelled output occurred between t1 and t2. To read from the status byte the current value of bit 6, it must be read twice (t3). In this case, the user then learns that the output is back to being leveled. In example (b), the controller detects an unlevelled state from the latched bit, and in the process of reading the bit, clears it. But the latched bit returns to "unleveled" because the current state of the RF output is still unlevelled. So, if the extended status byte is read a second time, the current state (unleveled) is measured.

On line 190, a Clear Status bytes statement (CS) is used to clear both status bytes. Then, they are read again to learn the current state of the 8340A.

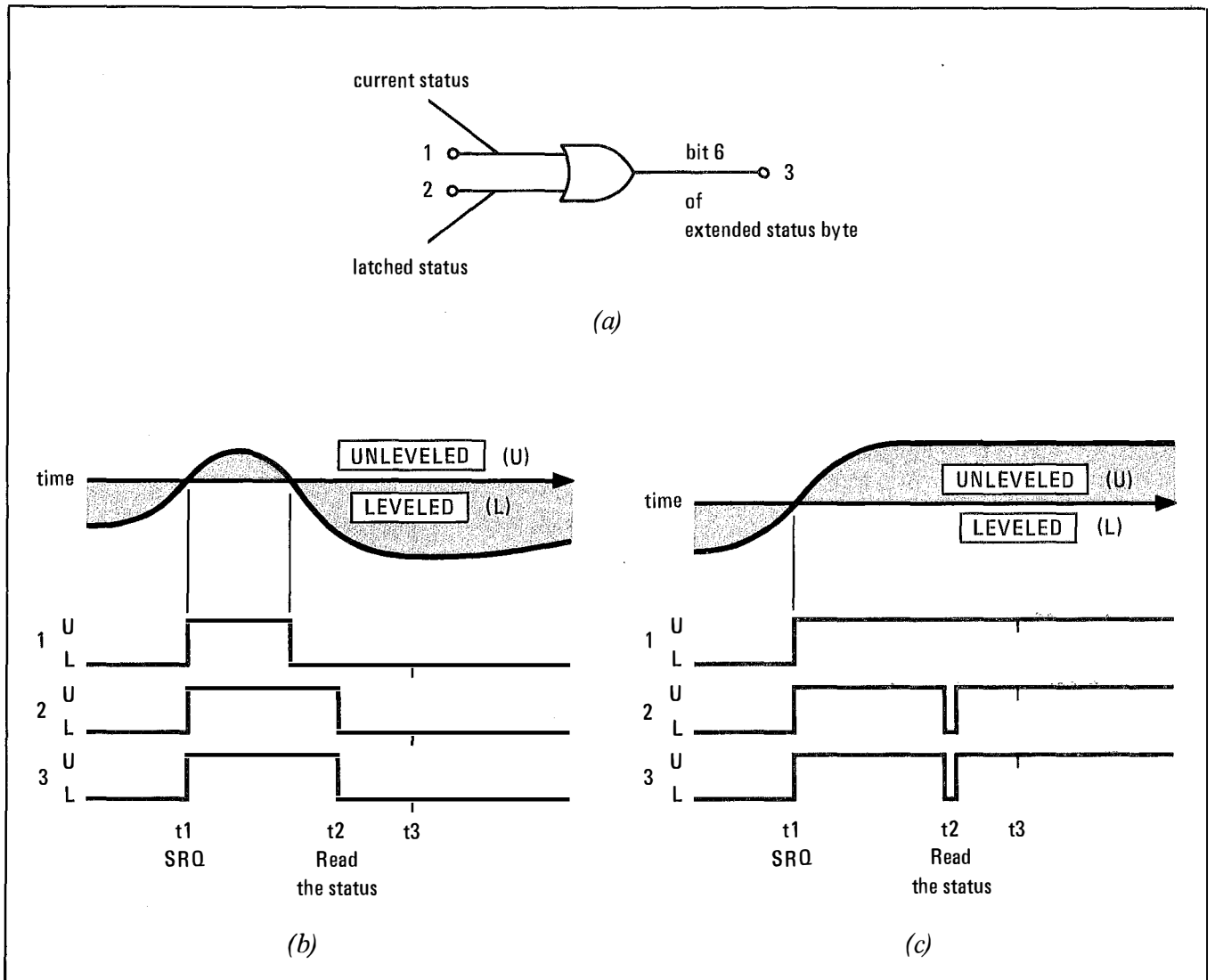

Figure 5. Example of Status Bit Latching

HP-IB PROGRAM CODES (1 of 2)

| CODE ^{1,2} | DESCRIPTION ³ | CODE ^{1,2} | DESCRIPTION ³ |
|---------------------|--|---------------------|--------------------------------------|
| A1 | Internal leveling | KZ | kHz |
| A2 | External leveling with crystal detector | M0 | Marker OFF |
| A3 | External leveling with power meter | M1 | Activates marker 1 |
| AKm | Turns RF amplitude markers ON/OFF | M2 | Activates marker 2 |
| ALm | Turns alternate sweep mode ON/OFF | M3 | Activates marker 3 |
| AMn | Enables/disables amplitude modulation | M4 | Activates marker 4 |
| ASm | *Alternate state select 0 = current front panel state 1 = recalled state | M5 | Activates marker 5 |
| AT | *Attenuator Setting | MC | Activate marker to center frequency |
| AU | Puts fixed function into Auto (coupled) mode | MDm | Turns marker difference ON/OFF |
| | | MPm | Turns marker sweep ON/OFF |
| | | MS | Milliseconds |
| | | MZ | MHz |
| BC | *Change frequency band | NAm | *Turns network analyzer mode ON/OFF |
| CF | Center Frequency | OA | *Output active parameter value |
| CS | Clear both status bytes | OB | *Output next bandcross frequency |
| CW | CW frequency | OC | *Output coupled parameters |
| | | OD | *Output diagnostic numbers |
| DB | dB or dBm | OF | *Output Fault |
| DF | Frequency span of sweep | OK | *Output last lock frequency |
| DN | Step down | OL | *Output learn string |
| DUm | *Disable/Re-enable Display Updating | OM | *Output mode string |
| | | OP | *Output interrogated parameter value |
| EF | Entry off | OR | *Output power level |
| EK | *Enable control knob | OS | *Output both status bytes |
| FA | Start frequency | PL | Power level |
| FB | Stop frequency | PMm | Enables/disables pulse modulation |
| | | PSm | Turns power sweep ON/OFF |
| GZ | GHz | RB | *Control knob remotely |
| HZ | Hz | RCn | Recalls instrument state |
| IF | *Increment frequency | RFm | Turns RF ON/OFF |
| IL | *Input learn string | RM | *Send service request mask |
| IP | Instrument preset | RPm | Turns RF peaking ON/OFF |
| | | RS | *Reset sweep |

NOTES

1. Program codes of the form "XXm" use "m" to turn the function On or Off (1 or 0).
2. The 8340A ignores spaces, plus signs, negative signs (except for the power values), and any unexpected characters. Program codes can be upper or lower case alpha characters.
3. Descriptions with an asterisk (*) beside them denote an HP-IB only command.

| CODE ^{1,2} | DESCRIPTION ³ | CODE ^{1,2} | DESCRIPTION ³ |
|---------------------|--|---------------------|---|
| S1 | Continuous sweep | SH M1 | Displays M, N, M/N loop frequency, 20/30 loop frequency |
| S2 | Single sweep | SH M2 | Displays band number, YIG oscillator frequency |
| S3 | Manual frequency sweep | SH M3 | Displays VCO1, VCO2 frequencies |
| SC | Seconds | SH M5 | Turn off diagnostic displays; restore display |
| SF | *Set frequency step size | SH M0 | Turn all markers OFF |
| SH | Shift key | SH MP | Start frequency to M1; stop frequency to M2; original start/stop values discarded |
| SLm | Turn slope ON/OFF | SH PL | Power step size |
| SM | *Manual frequency sweep | SH PS | Decouple ALC and attenuator for independent control |
| SP | *Set power step size | SH RC | Remove lock from Save/Recall registers |
| ST | Sweep time | SH RP | Automatic tracking calibration for swept mode |
| SVn | Save instrument state | SH S1m | Disable/re-enable display updating |
| T1 | Free run | SH S3 | Use when FAULT indicator comes on; blinking mnemonic shows cause of fault. See 8340A Operating and Service Manual. |
| T2 | Sweep triggered by power line frequency | SH SL | Attenuator setting |
| T3 | Sweep triggered externally | SH ST | Zoom mode |
| TI | *Test HP-IB interface | SH SV | Lock save registers |
| TS | Take sweep | SH T1 | Active display self test |
| UP | Step up | SH T2m | Enable/disable penlift for XY recorders at bandcrossing(s) |
| | SHIFT KEY FUNCTIONS | SH T3 | Use when UNLK annunciator comes on. Blinking mnemonic shows which oscillator is causing the unlocked condition. See 8340A Operating and Service Manual. |
| SH A1 | Cause manual band cross | | |
| SH A2m | Disable/re-enable bandcrossing capability | | |
| SH A3 | Disable ALC to control modulator drive directly | | |
| SH AM | Enable 100 kHz AM bandwidth while pulse modulating | | |
| SH CF | Frequency step size | | |
| SH CW | Set frequency resolution | | |

NOTES

1. Program codes of the form "XXm" use "m" to turn the function On or Off (1 or 0). For the storage register functions, the "n" is 1 through 9.
2. The 8340A ignores spaces, plus signs, negative signs (except for the power values), and any unexpected characters. Program codes can be upper or lower case alpha characters.
3. Descriptions with an asterisk (*) beside them denote an HP-IB only command.



For more information, call your local HP Sales Office or nearest Regional Office: **Eastern** (201) 265-5000; **Midwestern** (312) 255-9800; **Southern** (404) 955-1500; **Western** (213) 970-7500; **Canadian** (416) 678-9430. Ask the operator for Instrument sales. Or write Hewlett-Packard, 1501 Page Mill Road, Palo Alto, CA 94304. In Europe: Hewlett-Packard S.A., 7, rue du Bois-du-Lan, P.O. Box, CH 1217 Meyrin 2, Geneva, Switzerland. In Japan: Yokogawa-Hewlett-Packard Ltd., 29-21, Takaido-Higashi 3-chome, Suginami-ku, Tokyo 168.

H.P. Part No. 5952-9337

Printed in U.S.A.

Quick Reference Guide for the HP 8340A Synthesized Sweeper

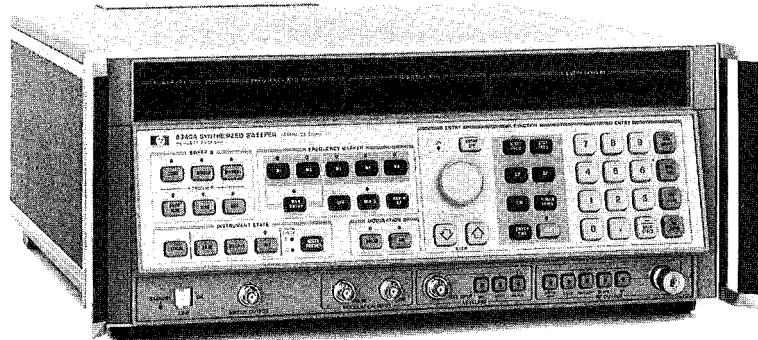

INTRODUCTION

This programming note is a reference guide for the remote operation of the HP 8340A Synthesized Sweeper. This note is intended for use by those familiar with HP-IB programming and the basic functions of the HP 8340A. For complete programming information refer to the HP 8340A Operating and Service manual.

HP-IB CAPABILITIES

The following codes describe the HP-IB electrical capabilities of the HP 8340A, using IEEE Std 488-1978 mnemonics (HP-IB, GP-IB, IEEE 488, and IEC-625 are all electrically equivalent). Briefly, the mnemonics translate as follows:

- SH1:** Source Handshake, complete capability.
- AH1:** Acceptor Handshake, complete capability.
- T6:** Talker, capable of basic talker, serial poll, and unaddress if MLA.
- TE0:** Talker, Extended address; no capability.
- L4:** Listener; capable of basic listener, and unaddress if MTA.
- LE0:** Listener, Extended address; no capability.

SR1: Service Request, complete capability.

RL1: Remote Local, complete capability.

PP0: Parallel Poll, no capability.

DC1: Device Clear, complete capability.

DT1: Device Trigger, complete capability.

C0, 1, 2, 3, 28: Controller capability options; C0, no capabilities; C1, system controller; C2, send IFC and take charge; C3, send REN; C28, send I.F. messages.

E1: Electrical specification indicating open collector outputs.

These codes are completely explained in the **IEEE Std 488-1978** document, published by The Institute of Electrical and Electronic Engineers, Inc., 345 East 47th Street, New York, New York 11017.

INPUT DATA

The 8340A Synthesized Sweeper accepts programming codes that contain information for programming all of the front panel and special HP-IB only functions except

except the Line switch and Set HP-IB Address. Programming data consists of a string of ASCII coded characters composed of one or more of the following control fields:

- Sweep Mode/Limits
- Frequency Markers
- Sweep Mode, Trigger, and Time
- Modulation
- Step Size, Display, and Entry Control
- Instrument State/Registers
- Power Level and Control
- Special HP-IB Only Functions
- Diagnostic Functions

INPUT SYNTAX

The 8340A responds to program codes in the order in which they are received. Each function is programmed with a string of ASCII coded characters that follow one of these sequences:

- [Function Code] [Numeric Value] [Numeric Terminator]
- [Function Code]

NOTE

The HP-IB program code sequence typically mirrors that of the local front panel keystroke sequence.

FUNCTION CODES (PREFIX ACTIVATE)

Function codes are typically 2 to 4 character mnemonics. For functions that have a numeric value associated with them, passing the function code only will enable and activate the function for further data entry.

NUMERIC VALUE (NUMERIC FORMAT)

These are either a single decimal digit, a set of 14 characters or less representing a number, or a string of binary bytes. A string of 14 characters maximum can be expressed in exponential, decimal or integer form. Acceptable numeric formats are referenced in later sections by the following format syntax:

- Format #1: Exponential $\pm d^{***}d.d^{***}dE \pm dd$
- Format #2: Decimal $\pm d^{***}d.d^{***}d$
- Format #3: Integer $\pm d^{***}d$
- Format #4: Single Digit d
- Format #5: Binary String $b^{***}b$
- Format #6: Binary Byte b

Where the character 'd' indicates a leading or trailing zero, a space, or a numeric digit (0 through 9). The character 'b' indicates an 8-bit binary byte. The characters '***' indicate a variable number of the

previous character. Numeric values that are not binary in nature are scaled by the appropriate numeric terminator.

NUMERIC TERMINATORS

Numeric terminators are of 2 types, mnemonic and fundamental terminators. Mnemonic terminators are 2-character codes that terminate and scale the associated numeric value. Thus, frequency values can be entered in GHz (GZ), MHz (MZ), kHz (KZ), or Hz (HZ); sweep time values can be entered in seconds (SC) or milliseconds (MS) and power values can be entered in dB or dBm (both DB). Fundamental terminators consist of the ASCII characters Line Feed or Next Line (LF or NL, decimal 10), semicolon (;, decimal 59), or comma (,, decimal 44), and may be used in lieu of a mnemonic terminator. However, when this is done the 8340A assumes the numeric value is in the fundamental units of Hz, seconds or dB.

VALID CHARACTERS

The alpha program codes can be either upper or lower case since the 8340A will accept either type (they can be interchanged). Spaces, unnecessary signs (+, -), leading zeroes and carriage returns (CR) are ignored. Characters containing a parity bit will have that bit cleared by the 8340A.

PROGRAMMING DATA

See Table 1 for Input Programming Codes.

NOTE

If different step attenuator settings exist between the foreground and background states of an Alternate Sweep, the 8340A will perform the Alternate Sweep function, but the step attenuator will not vary from the foreground state in order to avoid excessive attenuator wear.

INSTRUMENT PRESET

Instrument Preset turns off all functions then sets the following:

Sweep Mode: Start/Stop
Start = 10 MHz
Stop = 26.5 GHz

Sweep: Continuous

Trigger: Free Run

Sweep Time = 44.15 ms (minimum for full band)

Markers: All values set to center of frequency span, all off

Table 1. Input Programming Codes (1 of 6)

| MODE | FUNCTION | PROGRAM CODE | | | | NUMERIC VALUE | |
|---------------------------------------|---|-----------------|----------------|---------------------------------|------------------|---------------------------------|---|
| | | PREFIX ACTIVATE | NUMERIC FORMAT | SUFFIX | SCALE FACTOR | RANGE | RESOLUTION |
| SWEEP MODE/LIMITS | | | | | | | |
| Start/Stop Sweep | START | FA | 1,2,3,4 | GZ | $\times 10^9$ Hz | 10 MHz to 26.4999999 GHz | Greater than 0.1% of current ΔF |
| | STOP | FB | | | | 10.0001 MHz to 26.5 GHz | |
| Center Frequency/ ΔF Sweep | CF | CF | | MZ | $\times 10^6$ Hz | 10.00005 MHz to 26.49999995 GHz | Greater than 0.1% of current ΔF |
| | ΔF | DF | | | | KZ | |
| | ZOOM | SHST | | 10.00005 MHz to 26.49999995 GHz | | | |
| CW Frequency | CW | CW | | HZ | $\times 1$ Hz | 10 MHz to 26.5 GHz | 1 to 4 Hz, depending on frequency range |
| | CW RESOLUTION | SHCW | | | | | |
| FREQUENCY MARKERS | | | | | | | |
| Turn On And Set Marker Frequency | MARKER 1 | M1 | 1,2,3,4 | GZ | $\times 10^9$ Hz | 10 MHz to 26.5 GHz | Greater than 0.1% of Current ΔF |
| | MARKER 2 | M2 | | MZ | $\times 10^6$ Hz | | |
| | MARKER 3 | M3 | | KZ | $\times 10^3$ Hz | | |
| | MARKER 4 | M4 | | HZ | $\times 1$ Hz | | |
| | MARKER 5 | M5 | | | | | |
| Turn Off A Frequency Marker | M1 OFF | M1 | | M \emptyset | | | |
| | M2 OFF | M2 | | | | | |
| | M3 OFF | M3 | | | | | |
| | M4 OFF | M4 | | | | | |
| | M5 OFF | M5 | | | | | |
| Turn Off All Markers | ALL OFF | SHM \emptyset | | | | | |
| Turn On And Set Mkr Δ | MKR Δ , Marker "m" Marker "n" | MD1 | MmMn | | | Where: m,n: 1 to 5 | |
| Turn Off Mkr Δ | MKR Δ OFF | MD \emptyset | | | | | |
| Active Marker To Center Frequency | MKR \rightarrow CF | MC | | | | | |
| Marker 1-2 Sweep | MKR SWEEP ON | MP1 | | | | | |
| | MKR SWEEP OFF | MP \emptyset | | | | | |
| Marker 1 to Start Marker 2 to Stop | M1 \rightarrow START M2 \rightarrow STOP | SHMP | | | | | |

Table 1. Input Programming Codes (2 of 6)

| MODE | FUNCTION | PROGRAM CODE | | | NUMERIC VALUE | | |
|--|---|-----------------|----------------|--------|----------------------|--------------------------------|---|
| | | PREFIX ACTIVATE | NUMERIC FORMAT | SUFFIX | SCALE FACTOR | RANGE | RESOLUTION |
| FREQUENCY MARKERS (Cont'd) | | | | | | | |
| Amplitude Frequency Markers | AMPTD MKR ON | AK1 | | | | | |
| | AMPTD MKR OFF | AK0 | | | | | |
| SWEEP MODE, TRIGGER, AND TIME | | | | | | | |
| Sweep Mode | CONTINUOUS | S1 | | | | | |
| | SINGLE | S2 or SG | | | | | |
| | MANUAL FREQUENCY SWEEP | S3 or SM | 1,2,3,4 | GZ | $\times 10^9$ Hz | Present Start/Stop Frequencies | 1-4 Hz Depending On Frequency Range |
| | | | | MZ | $\times 10^6$ Hz | | |
| | | | | KZ | $\times 10^3$ Hz | | |
| | | | | HZ | $\times 1$ Hz | | |
| Sweep Trigger | FREE RUN | T1 | | | | | |
| | LINE | T2 | | | | | |
| | EXTERNAL | T3 | | | | | |
| Sweep Time | SWEEP TIME | ST | 1,2,3,4 | SC | $\times 1$ sec | 0.01 to 200 sec | Greater Than 0.1% Of Current Sweep Time |
| | | | | MS | $\times 10^{-3}$ sec | | |
| MODULATION | | | | | | | |
| Amplitude Modulation | AM ON | AM1 | | | | | |
| | AM OFF | AM0 | | | | | |
| Pulse Modulation | PULSE MOD. ON | PM1 | | | | | |
| | PULSE MOD. OFF | PM0 | | | | | |
| | INCREASE ALC BANDWIDTH IN PULSE MODE | SHAM | | | | | |
| | DISABLE ALC TO CONTROL MODULATOR DRIVE DIRECTLY | SHA3 | | | | | |
| STEP SIZE, DISPLAY, AND ENTRY CONTROL | | | | | | | |
| Set Frequency Step Size | FREQUENCY STEP SIZE | SF or SHCF | 1,2,3,4 | GZ | $\times 10^9$ Hz | 1 Hz to 10 GHz | 1-4 Hz Depending On Frequency Range |
| | | | | MZ | $\times 10^6$ Hz | | |
| | | | | KZ | $\times 10^3$ Hz | | |
| | | | | HZ | $\times 1$ Hz | | |
| Set Power Step Size | POWER STEP SIZE | SP or SHPL | 1,2,3,4 | DB | $\times 1$ dB | 0.05 dB to 50 dB | 0.05 dB |
| Increment Active Parameter ² | STEP UP ↑ | UP | | | | | |
| Decrement Active Parameter ² | STEP DOWN ↓ | DN | | | | | |
| Numeric Display Update | DISABLE DISPLAY UPDATE | SHS10 or DU0 | | | | | |
| | RE-ENABLE DISPLAY UPDATE | SHS11 or DU1 | | | | | |

Table 1. Input Programming Codes (3 of 6)

| MODE | FUNCTION | PROGRAM CODE | | | NUMERIC VALUE | | |
|--|---------------------------------|-----------------|----------------|----------------------|--|------------------------------------|------------|
| | | PREFIX ACTIVATE | NUMERIC FORMAT | SUFFIX | SCALE FACTOR | RANGE | RESOLUTION |
| STEP SIZE, DISPLAY, AND ENTRY CONTROL (Cont'd) | | | | | | | |
| X-Y Recorder Interface ³ | ENABLE PENLIFT AT BANDCROSSING | SHT21 | | | | | |
| | DISABLE PENLIFT AT BANDCROSSING | SHT20 | | | | | |
| Fixed Function To Coupled Mode | AUTO | AU | | | | | |
| Disable Active Function | ENTRY OFF | EF | | | | | |
| Display Scale | MULTIPLICATION FACTOR | SHFA | 1,2,3,4 | | ×1 | − 30 to + 30 | |
| Display Offset | OFFSET FACTOR | SHFB | 1,2,3,4 | GZ MZ KZ HZ | ×10 ⁹ Hz ×10 ⁶ Hz ×10 ³ Hz ×1 Hz | − 500 GHz to 500 GHz | 1 HZ |
| <p>2. In CW RES mode, step keys change resolution. In ZOOM, step keys change ΔF. When attenuator and ALC loop are decoupled, step keys change attenuator in 10 dB steps.</p> <p>3. Valid only when sweep time is ≥5 seconds.</p> | | | | | | | |
| INSTRUMENT STATE/REGISTERS | | | | | | | |
| Instrument Preset | INSTR PRESET | IP | | | | | |
| Save An Instrument State | SAVE n | SV | 4 | | ×1 | Registers 1 through 9 ⁴ | |
| Recall An Instrument State | RECALL n | RC | | | | | |
| Lock Registers | SAVE LOCK | SHSV | | | | | |
| Unlock Registers | SAVE UNLOCK | SHRC | | | | | |
| Alternate Sweep Mode | ALT ON | AL1 | 4 | | ×1 | Registers 1 through 9 | |
| | ALT OFF | AL0 | | | | | |
| 4. Register 0 contains the previous instrument state and can be recalled. However, SAVE 0 is not allowed. | | | | | | | |
| POWER LEVEL AND CONTROL | | | | | | | |
| Set Output Power Level | POWER LEVEL | PL | 1,2,3,4 | DB | ×1 dBm | 20 dBm to −90 dBm | 0.05 dB |
| Power Sweep Mode | POWER SWEEP ON | PS1 | 1,2,3,4 | DB | ×1 dB/Swp | 0 to 40.0 dB/Swp | 0.05 dB |
| | POWER SWEEP OFF | PS0 | | | | | |
| Power Slope Mode | SLOPE ON | SL1 | 1,2,3,4 | DB | ×1 dB/GHz | 0 to 1.5 dB/GHz | 0.001 dB |
| | SLOPE OFF | SL0 | | | | | |
| RF Power | RF ON | RF1 | | | | | |
| | RF OFF | RF0 | | | | | |
| Peak Output Power (CW Mode or Manual Sweep) | PEAK ON | RP1 | | | | | |
| | PEAK OFF | RP0 | | | | | |

Table 1. Input Programming Codes (4 of 6)

| MODE | FUNCTION | PROGRAM CODE | | | NUMERIC VALUE | | |
|---|---------------------------------------|-----------------|-----------------------------|--------|---------------|---------------------------------|------------|
| | | PREFIX ACTIVATE | NUMERIC FORMAT | SUFFIX | SCALE FACTOR | RANGE | RESOLUTION |
| POWER LEVEL AND CONTROL (Cont'd) | | | | | | | |
| Instantaneous Peak | FAST PEAKING | SHAK | | | | | |
| Peak Output Power (Swept Mode) | AUTO TRACKING CALIBRATION | SHRP | | | | | |
| Leveling Modes | INTERNAL | A1 | 1,2,3,4 | DB | ×1 dBv | -70 dBv to +10 dBv | 0.05dB |
| | EXTERNAL ⁵ CRYSTAL | A2 | | | | | |
| | EXTERNAL ⁵ POWER METER | A3 | | | | | |
| Independent ⁶ Control of ALC and Attenuator | DECOUPLE ALC AND ATTENUATOR | SHPS | | | | | |
| | CONTROL ALC INDEPENDENTLY | SHPS | 1,2,3,4 | DB | ×1 dB | 20 dBm to -20 dBm | 0.05 dB |
| | CONTROL STEP ATTENUATOR INDEPENDENTLY | SHSL or AT | 3 | DB | ×1 dB | -10 dB to -90 dB in 10 dB Steps | 10 dB |
| | RE-COUPLE ALC AND ATTENUATOR | PL ⁷ | | | | | |
| 5. Attenuator and ALC are automatically decoupled in this mode. ALC value is in dBv and is adjusted as shown. Attenuator may be adjusted using "AT" or "SHSL" commands as shown in this table. 6. INT mode only. Decoupling occurs automatically in XTAL and METER Modes. 7. Power output retains same level as last value in decoupled mode. | | | | | | | |
| SPECIAL HP-IB ONLY FUNCTIONS | | | | | | | |
| Status Bytes And Service Requests | OUTPUT STATUS | OS | | | | | |
| | STATUS BYTE MASK | RM | 6 | | | 1 byte | |
| | EXTENDED STATUS BYTE MASK | RE | 6 | | | 1 byte | |
| | CLEAR STATUS BYTE | CS | | | | | |
| Learn String | OUTPUT LEARN STRING | OL | | | | | |
| | INPUT LEARN STRING | IL | 5 | | | 123 bytes | |
| Mode String | OUTPUT MODE STRING | OM | 5 | | | 8 bytes | |
| Output Interrogated Parameter Value | OUTPUT INTERROGATED VALUE | OP | Interrogated Parameter Code | | | | |
| Output Active Parameter Value | OUTPUT ACTIVE VALUE | OA | | | | | |
| Output Power Level | OUTPUT POWER LEVEL | OR | | | | | |
| Output Diagnostic Numbers | OUTPUT DIAGNOSTICS | OD | | | | | |
| Output Fault | OUTPUT FAULT | OF | | | | | |

Table 1. Input Programming Codes (3 of 6)

| MODE | FUNCTION | PROGRAM CODE | | | NUMERIC VALUE | | |
|---|---------------------------------|-----------------|----------------|----------------------|--|------------------------------------|------------|
| | | PREFIX ACTIVATE | NUMERIC FORMAT | SUFFIX | SCALE FACTOR | RANGE | RESOLUTION |
| STEP SIZE, DISPLAY, AND ENTRY CONTROL (Cont'd) | | | | | | | |
| X-Y Recorder Interface ³ | ENABLE PENLIFT AT BANDCROSSING | SHT21 | | | | | |
| | DISABLE PENLIFT AT BANDCROSSING | SHT20 | | | | | |
| Fixed Function To Coupled Mode | AUTO | AU | | | | | |
| Disable Active Function | ENTRY OFF | EF | | | | | |
| Display Scale | MULTIPLICATION FACTOR | SHFA | 1,2,3,4 | | ×1 | − 30 to + 30 | |
| Display Offset | OFFSET FACTOR | SHFB | 1,2,3,4 | GZ MZ KZ HZ | ×10 ⁹ Hz ×10 ⁶ Hz ×10 ³ Hz ×1 Hz | − 500 GHz to 500 GHz | 1 HZ |
| 2. In CW RES mode, step keys change resolution. In ZOOM, step keys change ΔF. When attenuator and ALC loop are decoupled, step keys change attenuator in 10 dB steps. 3. Valid only when sweep time is ≥5 seconds. | | | | | | | |
| INSTRUMENT STATE/REGISTERS | | | | | | | |
| Instrument Preset | INSTR PRESET | IP | | | | | |
| Save An Instrument State | SAVE n | SV | 4 | | ×1 | Registers 1 through 9 ⁴ | |
| Recall An Instrument State | RECALL n | RC | | | | | |
| Lock Registers | SAVE LOCK | SHSV | | | | | |
| Unlock Registers | SAVE UNLOCK | SHRC | | | | | |
| Alternate Sweep Mode | ALT ON | AL1 | 4 | | ×1 | Registers 1 through 9 | |
| | ALT OFF | AL0 | | | | | |
| 4. Register 0 contains the previous instrument state and can be recalled. However, SAVE 0 is not allowed. | | | | | | | |
| POWER LEVEL AND CONTROL | | | | | | | |
| Set Output Power Level | POWER LEVEL | PL | 1,2,3,4 | DB | ×1 dBm | 20 dBm to − 90 dBm | 0.05 dB |
| Power Sweep Mode | POWER SWEEP ON | PS1 | 1,2,3,4 | DB | ×1 dB/Swp | 0 to 40.0 dB/Swp | 0.05 dB |
| | POWER SWEEP OFF | PS0 | | | | | |
| Power Slope Mode | SLOPE ON | SL1 | 1,2,3,4 | DB | ×1 dB/GHz | 0 to 1.5 dB/GHz | 0.001 dB |
| | SLOPE OFF | SL0 | | | | | |
| RF Power | RF ON | RF1 | | | | | |
| | RF OFF | RF0 | | | | | |
| Peak Output Power (CW Mode or Manual Sweep) | PEAK ON | RP1 | | | | | |
| | PEAK OFF | RP0 | | | | | |

Table 1. Input Programming Codes (4 of 6)

| MODE | FUNCTION | PROGRAM CODE | | | NUMERIC VALUE | | |
|---|---------------------------------------|-----------------|-----------------------------|--------|---------------|---------------------------------|------------|
| | | PREFIX ACTIVATE | NUMERIC FORMAT | SUFFIX | SCALE FACTOR | RANGE | RESOLUTION |
| POWER LEVEL AND CONTROL (Cont'd) | | | | | | | |
| Instantaneous Peak | FAST PEAKING | SHAK | | | | | |
| Peak Output Power (Swept Mode) | AUTO TRACKING CALIBRATION | SHRP | | | | | |
| Leveling Modes | INTERNAL | A1 | | | | | |
| | EXTERNAL ⁵ CRYSTAL | A2 | 1,2,3,4 | DB | ×1 dBv | -70 dBv to +10 dBv | 0.05dB |
| | EXTERNAL ⁵ POWER METER | A3 | | | | | |
| Independent ⁶ Control of ALC and Attenuator | DECOUPLE ALC AND ATTENUATOR | SHPS | | | | | |
| | CONTROL ALC INDEPENDENTLY | SHPS | 1,2,3,4 | DB | ×1 dB | 20 dBm to -20 dBm | 0.05 dB |
| | CONTROL STEP ATTENUATOR INDEPENDENTLY | SHSL or AT | 3 | DB | ×1 dB | -10 dB to -90 dB in 10 dB Steps | 10 dB |
| | RE-COUPLE ALC AND ATTENUATOR | PL ⁷ | | | | | |
| 5. Attenuator and ALC are automatically decoupled in this mode. ALC value is in dBv and is adjusted as shown. Attenuator may be adjusted using "AT" or "SHSL" commands as shown in this table. 6. INT mode only. Decoupling occurs automatically in XTAL and METER Modes. 7. Power output retains same level as last value in decoupled mode. | | | | | | | |
| SPECIAL HP-IB ONLY FUNCTIONS | | | | | | | |
| Status Bytes And Service Requests | OUTPUT STATUS | OS | | | | | |
| | STATUS BYTE MASK | RM | 6 | | | 1 byte | |
| | EXTENDED STATUS BYTE MASK | RE | 6 | | | 1 byte | |
| | CLEAR STATUS BYTE | CS | | | | | |
| Learn String | OUTPUT LEARN STRING | OL | | | | | |
| | INPUT LEARN STRING | IL | 5 | | | 123 bytes | |
| Mode String | OUTPUT MODE STRING | OM | 5 | | | 8 bytes | |
| Output Interrogated Parameter Value | OUTPUT INTERROGATED VALUE | OP | Interrogated Parameter Code | | | | |
| Output Active Parameter Value | OUTPUT ACTIVE VALUE | OA | | | | | |
| Output Power Level | OUTPUT POWER LEVEL | OR | | | | | |
| Output Diagnostic Numbers | OUTPUT DIAGNOSTICS | OD | | | | | |
| Output Fault | OUTPUT FAULT | OF | | | | | |

Table 1. Input Programming Codes (5 of 6)

| MODE | FUNCTION | PROGRAM CODE | | | NUMERIC VALUE | | |
|---|--------------------------------------|-----------------|----------------|--------|-----------------------------------|---------------|------------|
| | | PREFIX ACTIVATE | NUMERIC FORMAT | SUFFIX | SCALE FACTOR | RANGE | RESOLUTION |
| SPECIAL HP-IB ONLY FUNCTIONS (Cont'd) | | | | | | | |
| Output Coupled Parameters | OUTPUT COUPLED PARAMETERS | OC | | | | | |
| Output Last Lock Frequency | OUTPUT LAST LOCK FREQUENCY | OK | | | | | |
| Output Next Bandcross Frequency | OUTPUT NEXT BANDCROSS | OB | | | | | |
| Outputs Model Number & Software Rev Date | OUTPUT IDENTIFY | OI | | | | | |
| Sweep Functions | STEPPED SWEEP | SN | 1,2,3,4 | | × 1 | 10 to 1000 | |
| | TIME LIMIT | TL | 1,2,3,4 | SC MS | × 1 sec × 10 ⁻³ sec | .01 to 40 sec | .001 sec |
| Fast Phaselock | FAST PHASELOCK SELECT | FP | | | | | |
| Single Sweep Start/Stop | RESET SWEEP | RS | | | | | |
| | TAKE SWEEP | TS | | | | | |
| Increment Frequency By Frequency Step Size | INCREMENT FREQUENCY | IF ⁸ | | | | | |
| Enable Control Knob | ENABLE KNOB | EK | | | | | |
| Control Knob Remotely | RPG BYTE | RB | 6 | | | 1 byte | |
| Alternate State Selection | SELECT CURRENT FRONT PANEL | AS0 | | | | | |
| | SELECT RECALLED STATE | AS1 | | | | | |
| Network Analyzer Functions | NETWORK ANALYZER CONFIGURE | NA | 6 | | | 1 byte | |
| | ADVANCE TO NEXT BANDCROSSING | BC | | | | | |
| | KEYBOARD RELEASE | KR | | | | | |
| | SWAP CHANNELS | SW0 SW1 | | | | | |
| Test HP-IB Interface | TEST INTERFACE | TI | 6 | | | 1 byte | |
| 8. CW and MANUAL modes only. Frequency need not be the active function to utilize this command. | | | | | | | |
| DIAGNOSTIC FUNCTIONS | | | | | | | |
| Display M/N and 20/30 Loop Frequencies | DISPLAY M, N, M/N FREQ., 20/30 FREQ. | SHM1 | | | | | |
| Display Band # And Y.O. Loop Frequency | DISPLAY BAND # AND Y.O. FREQ. | SHM2 | | | | | |
| Display VCO1 And VCO2 Frequencies | DISPLAY VCO1 AND VCO2 | SHM3 | | | | | |

Table 1. Input Programming Codes (6 of 6)

| MODE | FUNCTION | PROGRAM CODE | | | NUMERIC VALUE | | |
|--------------------------------------|---------------------------|-----------------|----------------|--------|---------------|-------|------------|
| | | PREFIX ACTIVATE | NUMERIC FORMAT | SUFFIX | SCALE FACTOR | RANGE | RESOLUTION |
| DIAGNOSTIC FUNCTIONS (Cont'd) | | | | | | | |
| Front Panel Display Test | DISPLAY TEST | SHT1 | | | | | |
| Display Unlock Indicators | DISPLAY UNLOCK INDICATORS | SHT3 | | | | | |
| Display Fault Indicators | DISPLAY FAULT INDICATORS | SHS3 | | | | | |
| Band Cross Control | DISABLE BAND CROSS | SHA21 | | | | | |
| | RE-ENABLE BAND CROSS | SHA20 | | | | | |
| Cause Manual Band Cross | MANUAL BAND CROSS | SHA1 or BC | | | | | |
| Turn Off Diagnostic Displays | DIAGNOSTICS OFF | SHM5 | | | | | |

Modulation: Off

Frequency Step Size: Set to default value (10% of span)

Status Bytes: Cleared

Leveling: Internal

RF Output: On

Power Level = 0 dBm

Power Step Size: Set to default value (10 dB)

Power Sweep/Slope: Set to 0 dB

Storage Registers: Retain current values

HP-IB Address: Retains current value

Status Byte Mask: Unchanged

Extended Status Byte Mask: Unchanged

OUTPUT DATA

The 8340A has several output modes that allow the user to learn and interrogate the present instrument state. These output modes and their usage are shown in Table 2, and the program codes and syntax to enable each function are shown in Table 1.

The Learn String, Mode String, and Status functions send a Data message consisting of a string of 8-bit binary bytes. These messages are terminated by asserting the bus EOI signal in parallel with the last byte of the message to be sent. The other functions send a Data message consisting of up to 14 character ASCII

strings representing the numeric value in exponential form terminated with a Line Feed or Next Line (i.e. LF = NL = decimal 10).

Binary Syntax: [b***b] [EOI]

Numeric Syntax: [\pm d.dddddE \pm dd] [LF]

The character 'b' indicates an 8-bit binary byte and 'd' indicates a decimal digit (0 through 9). Note that the binary output format could have bytes that may be misinterpreted as Line Feeds so the user should defeat the ASCII LF as a valid character string terminator and rely on the byte count.

TRIGGER

The 8340A responds to HP-IB commands Group Execute Trigger (GET) and Selective Device Trigger (SDT) identically. The specific response is dictated by the current mode of the instrument. The 8340A determines this mode by a series of tests performed in the order below. Note that once the 8340A sees that it is in a certain mode it will perform the appropriate function and no other.

First test: If the 8340A is in the FAST PHASE LOCK (FP) mode the current frequency will be incremented by the frequency step.

Second test: If the 8340A is in the NETWORK ANALYZER (NA) mode and it is in the middle of a sweep it will immediately initiate a new sweep. If it is in the NA mode and it is not in the middle of a sweep

Table 2. Output Modes

| MODE | PRO-GRAMMING CODE | DESCRIPTION | FORMAT | NOTES |
|-------------------------------------|-----------------------|--|---------------------------------|--|
| Output Learn String | OL | Outputs binary data string 123 bytes long which completely describes instrument state. Can be stored in ASCII character data string and later input to 8340A to restore that instrument state. (See "IL" command.) | 123[8 bytes][EOI] | String does not include storage register contents. Information is packed, so data analysis is difficult. Learn string length is fixed. |
| Output Mode String | OM | Outputs binary string 10 bytes long. First bytes describe all presently active 8340A functions. Last byte tells which function is currently active (i.e., shown in entry display). String only tells which functions are active; does not give numeric values. | 10[8 bit bytes][EOI] | Information in first bytes is packed. Mode string length is fixed. If numeric values desired, use "OA" or "OP" modes (see below). |
| Output Interrogated Parameter Value | OP [Function code] | Outputs the present numeric value of function selected. | [\pm d.dddddE \pm dd][LF] | Output data in Hz, dBm, dB, or sec., implied by function selected. |
| Output Active Parameter Value | OA | Outputs present numeric value of currently active function (i.e., shown in ENTRY DISPLAY). | [\pm d.dddddE \pm dd][LF] | Output data in Hz, dBm, dB, or sec., implied by function selected. |
| Output Status | OS | Outputs 2 sequential 8-bit bytes giving present 8340A status. First Status Byte equivalent to that of Serial Poll, second is Extended Status Byte. | 2[8 bit bytes][EOI] | Table 3 describes both status bytes. Status bytes cleared by Serial Poll, SPD, DCL, "CS" command, Instrument Preset, or Power On. |
| Output Power | OR | Outputs value currently displayed in POWER dBm display of 8340A. | [\pm d.dddddE \pm dd][LF] | Output data in dBm. Value in POWER dBm display is always read regardless of leveling mode. |
| Output Diagnostic Numbers | OD | Outputs diagnostic numbers shown in 8340A display after one of the diagnostic functions SHM1, SHM2, or SHM3 has been activated. | m[\pm d.dddddE \pm dd][LF] | m = 4 for SHM1 m = 2 for SHM2, SHM3 M, N, and Band number are output as dimensionless quantities; all other data output in Hz. |
| Output Fault | OF | Outputs in ASCII form a number which can be decoded to determine locations which have caused the FAULT or UNLK annunciators to come on. | [\pm d.dddddE \pm dd][LF] | Conditions are accumulated by 8340A and cleared only by Power On, Instrument Preset, or "OF" command. |
| Output Last Lock Frequency | OK | Outputs the frequency to which 8340A most recently phase-locked. | [\pm d.dddddE \pm dd][LF] | Output data in Hz. |
| Output Coupled Parameters | OC | Outputs (in order): Start frequency, center frequency, and sweep time. | 3[\pm d.dddddE \pm dd][LF] | Output data in Hz and sec. |
| Output Next Bandcross Frequency | OB | Outputs the frequency which begins the next frequency band the 8340A would enter if it continues to sweep after the command is received. | [\pm d.dddddE \pm dd][LF] | Output data in Hz. |
| Output Identification | OI | Outputs the revision date of the firmware currently loaded in the 8340A. | 08340AREV day month year | 19 ASCII characters (2 numbers for the day, 3 letters for the month and 2 numbers for the year). |

then no operation will be performed.

Third test: If the 8340A is in the CW (CW) or MANUAL SWEEP (SM or S3) mode an Increment Frequency (IF) operation will be performed.

Fourth test: If the 8340A is in the middle of a sweep the sweep will be aborted and will restart a new sweep.

Fifth test: Finally, if the 8340A is in the SINGLE SWEEP (S2) mode it will start a new sweep.

CLEAR

The 8340A responds to both Device Clear (DCL) and Selective Device Clear (SDC) by clearing both status bytes and initializing the interface so that it is ready to receive HP-IB programming codes. This is necessary if the instrument state prior to sending HP-IB commands is unknown. It is good practice to execute DCL or SDC at the beginning of any program.

REMOTE/LOCAL CHANGES

The 8340A goes to the Remote state when the REN line is true (low) and the 8340A receives its listen address. In Remote, all front panel functions are disabled except the LINE switch and the LOCAL key. The LOCAL function can also be disabled via the Local Lockout (LLO) command.

The 8340A goes to the Local state when it receives the Go To Local (GTL) command or when the REN line is set false (high). If the Local Lockout (LLO) command has not been executed, the 8340A can also be set to Local by pressing the LOCAL key. In Local, the front panel is active but the instrument will still respond to HP-IB programming codes.

SERVICE REQUEST

The 8340A can initiate a Service Request (SRQ) whenever one of the following conditions exists:

- New frequencies or sweep time in effect
- Error in syntax
- End of sweep
- Phase lock sequence completed (RF settled)
- Change in Extended Status Byte bit(s)
- Numeric entry complete
- Front panel key pressed

Further information can be obtained by conducting a Serial Poll or by executing the Output Status command, both of which access Status Byte information. The SRQ is cleared only by executing a Serial

Poll. To select an SRQ for a particular set of circumstances, the Request Mask function can be used to determine which of the bits in the first Status Byte can cause an SRQ. The mask value is determined by summing the decimal values of each selected function/condition that is desired. The default Request Mask at power on is '00000000' or decimal 0. This mask value is reset to the default value only at power on or by execution of the DCL or SDC commands.

STATUS BYTE

The 8340A responds to a Serial Poll by sending its status byte as indicated in Table 3. The Extended Status Byte is available but must be accessed via the Output Status command. When Bit 6 (Request Service) of the Status Byte is true (one), an SRQ has occurred. See **Service Request** for the conditions causing a Service request. Bit 2 indicates whether a change has occurred in the Extended Status Byte. If Bit 2 is true, then the second status byte should be accessed via the Output Status command to determine the cause of the status change. All other bits (7, 5, 4, 3, 1, 0) indicate the present status of the noted function. The bits are true (one) if and only if the associated function/condition is true.

STATUS BIT

The 8340A does not respond to a Parallel Poll.

CONTROLLER CAPABILITIES

The 8340A does not have the ability to take or pass control.

ABORT

The 8340A responds to the Abort message (Interface Clear — IFC true) by stopping all Listener or Talker functions.

ADDRESS ASSIGNMENT INFORMATION

The 8340A basic address is factory preset to decimal 19. In the Local mode, this address can be changed from the front panel by pressing the SHIFT and then the LOCAL keys. ENTRY DISPLAY will show the current address; a new one can be entered via the 8340A keyboard. The new address will remain until changed by the operator.

Table 3. 8340A Status Byte Descriptions

| STATUS BYTE (#1) | | | | | | | | |
|---------------------------|--|-----------------------|---------------------------|---------------------|------------------------------|---------------------------------------|---|------------------------------------|
| BIT # | 7 | 6 | 5 | 4 | 3 | 2 | 1 | 0 |
| DECIMAL VALUE | 128 | 64 | 32 | 16 | 8 | 4 | 2 | 1 |
| FUNCTION | SRQ on New frequencies or Sweep Time in Effect | REQUEST SERVICE (RQS) | SRQ on HP-IB Syntax Error | SRQ on End of Sweep | SRQ on RF Settled | SRQ on Change in Extended Status Byte | SRQ on Numeric Entry Completed (HP-IB or Front Panel) | SRQ on Any Front Panel Key Pressed |
| EXTENDED STATUS BYTE (#2) | | | | | | | | |
| BIT # | 7 | 6 | 5 | 4 | 3 | 2 | 1 | 0 |
| DECIMAL VALUE | 128 | 64 | 32 | 16 | 8 | 4 | 2 | 1 |
| FUNCTION | Fault Indicator On | RF Unleveled | Power Failure | RF Unlocked | External Freq. Ref. Selected | Oven Cold | Over Modulation | Self Test Failed |



For more information, call your local HP Sales Office or nearest Regional Office: **Eastern** (201) 265-5000; **Midwestern** (312) 255-9800; **Southern** (404) 955-1500; **Western** (213) 970-7500; **Canadian** (416) 678-9430. Ask the operator for instrument sales. Or write Hewlett-Packard, 1501 Page Mill Road, Palo Alto, CA 94304. In **Europe**: Hewlett-Packard S.A., 7, rue du Bois-du-Lan, P.O. Box, CH 1217 Meyrin 2, Geneva, Switzerland. In **Japan**: Yokogawa-Hewlett-Packard Ltd., 29-21, Takaido-Higashi 3-chome, Suginami-ku, Tokyo 168.

5953-8877

Printed in U.S.A.

SECTION IV PERFORMANCE TESTS

4-1. INTRODUCTION

4-2. The procedures in this section and the following section (Automated Test Procedures) test the 8340A's electrical performance using the specifications of Table 1-1 as the performance standards. All tests can be performed without access to the interior of the instrument. An HP-IB Operation Verification procedure is also provided at the end of this section to verify proper HP-IB operation of the instrument.

NOTE

The Automated Test Procedures provided include additional tests that would be impossible or too tedious to test with a manual procedure (Frequency Switching Time and RF Attenuator Performance). The automated tests also include several tests that allow adjustments to be made or calibration constants to be accessed or changed.

4-3. EQUIPMENT REQUIRED

4-4. Equipment required for the manual Performance Test Procedures documented in this section is listed in the Recommended Test Equipment table in Section I of this manual. Any equipment that satisfies the critical specifications

given the table may be substituted for the recommended model listed. Additional test equipment required for the Automated Performance Tests is included in that section (following this section) as well as in the Recommended Test Equipment List in Section I.

4-5. TEST RECORD

4-6. Results of the manual Performance Test procedures may be tabulated on the test record card located at the end of this section. Results of the Automated Test Procedures are tabulated automatically at the end of each procedure. A complete test record card consists of the manual and automatic test results. Each test lists all of the tested specifications and their acceptable limits. The results recorded at incoming inspection can be used for comparison in periodic maintenance and troubleshooting and after repairs or adjustments have been made. Refer to the Automated Test Procedures section for more detailed information on how to access the data included in those tests.

4-7. CALIBRATION CYCLE

4-8. This instrument requires periodic verification of performance. The instrument should be checked using the following performance tests at least once a year.

Table 4-1. List of Manual Performance Tests¹

| Paragraph | Performance Test Title | Page |
|-------------------|---|------|
| 4-9 | Internal Time Base Aging Rate | 4-3 |
| 4-10 | Frequency Range and CW Mode Accuracy | 4-6 |
| 4-11 | Sweep Time Accuracy | 4-12 |
| 4-12 | Swept Frequency Accuracy | 4-14 |
| 4-13 | Maximum Leveled Output Power and Power Accuracy | 4-18 |
| 4-14 | External Leveling | 4-26 |
| 4-15 | Spurious Signals Test (10 MHz to 22 GHz) | 4-30 |
| 4-16 | Spurious Signals Test (22 to 26.5 GHz) | 4-33 |
| 4-17 | Single Sideband Phase Noise | 4-36 |
| 4-18 | Power Sweep Test | 4-43 |
| 4-19 | Pulse Modulation ON/OFF Ration Test ³ | 4-46 |
| 4-20 | Pulse Modulation Rise and Fall Time Test ³ | 4-48 |
| 4-21 | Pulse Modulation Accuracy Test ³ | 4-52 |
| 4-22 | Pulse Modulation Video Feedthrough Test ³ | 4-56 |
| 4-23 | Amplitude Modulation Test | 4-60 |
| 4-24 ² | HP-IB Operation Verification Test | 4-65 |

1. This list does not include the automated tests for Frequency Switching Time and RF Attenuator Performance, each of which are also required to complete the performance testing of the HP 8340A.

2. This is not a Performance Test. It is included as an additional aid to determine that the HP-IB circuitry is operating properly.

3. This test is not applicable to instruments equipped with Option 006, Delete Pulse Modulation.

4-9. INTERNAL TIME BASE AGING RATE

NOTE

The overall accuracy of the Model 8340A 10 MHz internal time base is a function of time base calibration \pm aging rate \pm temperature effects \pm line effects.

For greatest frequency accuracy, the time base should be allowed to warm up until the output frequency has stabilized (usually 7 to 30 days) before calibrating (adjusting the time base frequency to a known standard). After calibration, the change in time base frequency should remain within the aging rate if: the time base oven is not allowed to cool down, the instrument orientation with respect to the earth's magnetic field is maintained, and the instrument does not sustain any mechanical shock. Frequency changes due to orientation with respect to the earth's magnetic field and altitude changes will usually be nullified when the instrument is returned to its original position. Frequency changes due to mechanical shock will usually appear as a fixed frequency error.

If the instrument is disconnected from ac power allowing the time base oven to cool down, it may be necessary to readjust the time base frequency after a new warmup cycle; however, in most cases, the time base frequency will return to within \pm 1 Hz of the original frequency.

Specification

Table 4-2. Internal Time Base Aging Rate Specifications

| |
|--|
| <p>Aging Rate: 1×10^{-9} per day, 2.5×10^{-7} per year after 72-hour warm up if 8340A has been disconnected from ac power for less than 24 hours. Aging rate is achieved after 7 to 30 days warm-up if 8340A has been disconnected from ac power for greater than 24 hours.</p> <p>Accuracy: Overall accuracy of internal time base is a function of time base calibration \pm aging rate \pm temperature effects \pm line effects.</p> |
|--|

Description

A reference signal from the 8340A under test is connected to the oscilloscope's vertical input. A frequency standard (with long term stability greater than 1×10^{-10}) is connected to the oscilloscope trigger input. The time required for a specific phase change is measured immediately and after a period of time. The aging rate is inversely proportional to the absolute value of the difference in the measured times.

4-9. INTERNAL TIME BASE AGING RATE (Cont'd)

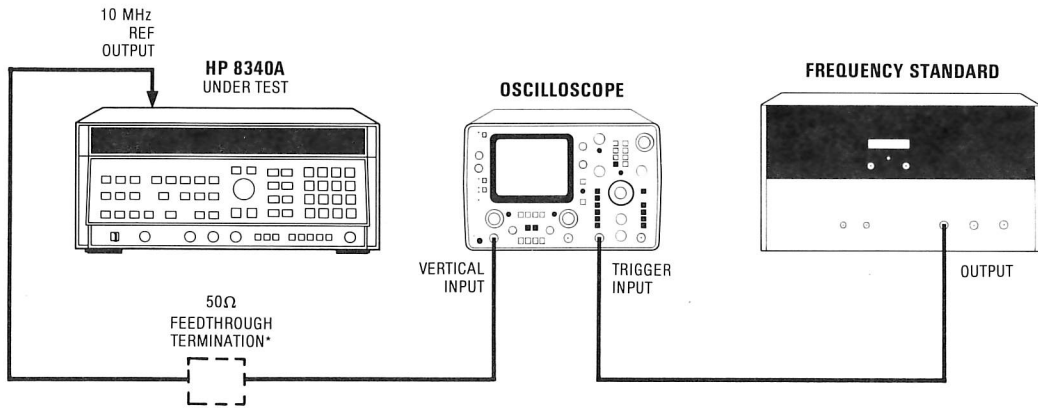

*Required only for oscilloscopes not having 50Ω input capability

Figure 4-1. Internal Time Base Aging Rate Test Setup

Equipment

- Frequency Standard..... HP 5061A
- Oscilloscope*..... HP 1741A

* A 50 Ohm Feedthrough Termination (such as the HP 10100C) is required when using an oscilloscope without a 50 Ohm input. It is not required with the HP 1741A.

NOTE

Be sure the 8340A has had 30 days to warmup before beginning this test. If the 8340A was disconnected from the ac power line for less than 24 hours, only a 24 hour warmup is required.

Procedure

1. Connect the equipment as shown in Figure 4-1.
2. Adjust the oscilloscope external triggering controls for a stable display of the 8340A 10 MHz REF OUTPUT signal.
3. Measure the time required for a phase change of 360 degrees. Record the time (T1) in seconds.

T1 = _____ seconds (s)

4. Wait for a period of time (from 3 to 24 hours) and remeasure the phase change time (repeat step 3). Record the period of time between measurements (T2) in hours and the new phase change time (T3) in seconds.

T2 = _____ hours (h)

T3 = _____ seconds (s)

4-9. INTERNAL TIME BASE AGING RATE (Cont'd)

5. Calculate the aging rate from the following equation:

$$\text{Aging Rate} = (1 \text{ cycle}/f)(1/T1 - 1/T3)(T/T2)$$

Where: 1 cycle = the phase change reference for the time measurement. (in this case, 360 degrees)

- f = 8340A Time Base output frequency (10 MHz)
 T = specified time for aging rate (24 hours)
 T1 = initial time measurement (s) for 360 degree (1 cycle change)
 T2 = time between measurements (h)
 T3 = final time measurement (s) for a 360 degree (1 cycle) change

For example, if:

- T1 = 351s
 T2 = 3h
 T3 = 349s

Then:

$$\begin{aligned} \text{Aging Rate} &= (1 \text{ cycle}/10 \text{ MHz})(1/351\text{s} - 1/349\text{s})(24\text{h}/3\text{h}) \\ &= 1.306 \times 10^{-11} \text{ per day} \end{aligned}$$

6. Verify that the aging rate is less than 1×10^{-9} per day

NOTE

If the absolute frequencies of the frequency standard and the 8340A Time Base oscillator are extremely close, the measurement time in steps 3 and 4 (T1 and T3) can be reduced by measuring the time required for a phase change of less than 360 degrees. Change "1 cycle" in the equation accordingly (i.e., 180 degrees = 1/2 cycle, or 90 degrees = 1/4 cycle).

7. If the aging rate is not within the required tolerance, be sure sufficient warmup time has been allowed and that the environmental conditions have not changed throughout the test, then check the Time Base heater circuit and, if necessary, replace the Time Base. Refer to service and repair information for the A51 10 MHz Reference Oscillator in the Reference Loop – M/N Loop portion of Section VIII, Service.

4-10. FREQUENCY RANGE AND CW MODE ACCURACY

Specification

Table 4-3. Frequency Range and CW Mode Accuracy Specifications

| |
|---|
| <p>Range: 0.01 to 26.50 GHz</p> <p>Resolution: $n \times 1$ Hz Where n = harmonic multiplication number (1 to 4). Refer to Frequency Ranges and Bandswitch Points description in Table 1-1.</p> <p>Accuracy: Same as Time Base Accuracy (refer to Table 1-1).</p> |
|---|

Description

The 8340A RF output is fed to a frequency counter. The frequency counter internal time base is used as the reference for the 8340A to eliminate time base error from the measurement. The 8340A frequency display and the counter display should agree, within the resolution of each instrument. This procedure does not test for CW mode accuracy as a function of the time base accuracy.

NOTE

A fault in the 8340A could cause the two displays to be different. Any fault that would cause one of the phase lock loops to be unlocked would be indicated by a front-panel FAULT indication; however, all 8340A internal phase lock loops could be locked and the 8340A output frequency could be in error (i.e., a phase lock loop frequency divider bit could be stuck). If all the dividers work normally, then CW mode frequency accuracy is essentially guaranteed.

In the following procedure, the test frequencies are selected first to test the maximum frequency range and then to exercise each frequency related circuit throughout its CW range while holding all remaining circuits constant. The test frequencies are grouped so that an abnormal indication would point to the circuit most likely causing the problem.

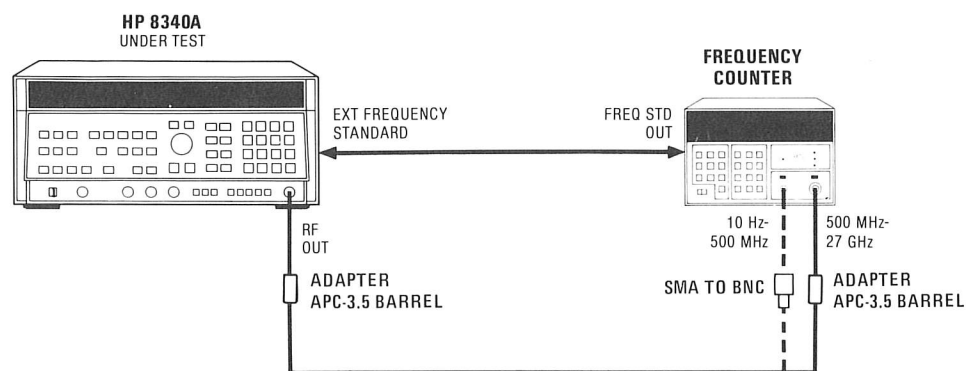

Figure 4-2. Frequency Range Test Setup

4-10. FREQUENCY RANGE AND CW MODE ACCURACY (Cont'd)**Equipment**

Frequency Counter..... HP 5343A
 Adapter..... HP P/N 5061-5311 (APC 3.5 Female to Female barrel)
 Cable HP P/N 8340-20124 (Semi-rigid SMA Male to SMA Male)

Procedure

1. Connect the equipment as shown in Figure 4-2. Connect the 8340A RF Output to the 10 MHz-500 MHz counter input. Allow at least 30 minutes warm up time. The 8340A under test and the Frequency Counter use the same frequency standard to eliminate time base error from the measurement. Set the 8340A rear panel FREQUENCY STANDARD switch to EXT.
2. Press 8340A [INSTR PRESET], then [CW] and enter [1] [0] [MHz]. Press [POWER LEVEL] and enter [-] [2] [0] [dBm]. The counter should indicate 10 MHz \pm 1Hz \pm the resolution of the counter.
3. Connect the 8340A RF output to the 500 MHz-26.5 GHz counter input. Press the 8340A [CW] key and enter [2] [6] [.] [5] [GHz]. The counter should indicate 26.5 GHz \pm 4 Hz \pm the resolution of the counter.

NOTE

Since the same time base is used for both the 8340A and the frequency counter, only the displayed frequency is checked. The actual frequency error is \pm (8340A output frequency/10 MHz) X time base error \pm 4 Hz.

4. Check the M/N Divider frequencies as follows:

NOTE

**Pressing [SHIFT] [M1] displays, from left to right, the:
 M divide number,
 N divide number,
 M/N Loop output frequency,
 20/30 Loop output frequency.**

Press [SHIFT] [M5] to exit this diagnostic mode. The instrument continues to operate normally while in the diagnostic display mode.

- a. Press the [CW] key and enter [2] [4] [9] [0] [MHz]. Select a step size of 10 MHz by pressing [SHIFT] [CF] [1] [0] [MHz]. Press [SHIFT] [M1] to display, from left to right, the M divide number, the N divide number, the M/N Loop output frequency, and the 20/30 Loop output frequency. Press the [CW] key to display the CW frequency in the [ENTRY DISPLAY].
- b. Using the down arrow key, step down to 2 300.000000 MHz. Check the counter indication at each step. The counter should indicate the 8340A frequency \pm 1Hz \pm the resolution of the counter at each step.

4-10. FREQUENCY RANGE AND CW MODE ACCURACY (Cont'd)**NOTE**

The above step sets and holds the N Divider to 13 and programs the M Divider through its full range of 8 to 27. Any frequency error as a result of a problem in the M Divider will probably be a multiple of 10 MHz.

- c. If a significant frequency error is evident, note the conditions under which the error occurred and continue this procedure to determine if any other conditions produce an error.
5. Check the M/N N Divider frequencies as follows:
 - a. Select a step size of 200 MHz by pressing **[SHIFT] [CF] [2] [0] [0] [MHz]**. Press **[CW]** to display the CW frequency in the **[ENTRY DISPLAY]**. The CW frequency should be 2 300.000000 MHz.
 - b. Using the up arrow key, step up to 6 900.000000 MHz. Check the counter indication at each step. the counter should indicate the 8340A frequency $\pm 1 \text{ Hz} \pm$ the resolution of the counter.

NOTE

The above step sets and holds the M Divider to 27 and programs the N Divider through its full range of 13 to 36. Any frequency error as a result of a problem in the M Divider will probably be a multiple of 10 MHz.

- c. If a significant frequency error is evident, note the conditions under which the error occurred and continue this procedure to determine if any other conditions produce an error.
6. Check the 20/30 MHz N2 loop frequencies as follows:
 - a. Press **[INSTR PRESET]**. Press **[CF]** key and enter **[2] [3] [1] [0] [.] [5] [MHz]**. Press the **[ΔF]** key and enter **[1] [MHz]**. Select a step size of 1 kHz by pressing **[SHIFT] [CF] [1] [kHz]**.
 - b. Press **[SINGLE]** sweep key to set the 8340A to be phase-locked at the start of sweep (2.310 GHz). Press **[SHIFT] [M1]** to enter the diagnostic display mode. Press **[CF]** to display the center frequency in the **[ENTRY DISPLAY]**. The center frequency should be 2.310500 GHz.
 - c. Using the up arrow key, step the center frequency up to 2.310510 GHz. Check the counter indication at each step. The counter should indicate the 8340A start frequency (CF - 0.0005 GHz) $\pm 1 \text{ Hz} \pm$ the resolution of the counter.

4-10. FREQUENCY RANGE AND CW MODE ACCURACY (Cont'd)**NOTE**

The above steps set the output of the M/N loop to 180 MHz where M=26 and N=13. The YO start frequency (2310 MHz) is then 20 to 30 MHz below the Nth harmonic (N=13) of 180 MHz ($180 \times 13 = 2340$). The 20/30 MHz output is then 30 MHz. Since the ΔF frequency (1 MHz) is between 0.1 to 5 MHz, the 20/30 MHz frequency is derived from the PLL2 75 to 150 MHz VCO output divided by 5 ($150 \text{ MHz} / 5 = 30 \text{ MHz}$). The PLL2 VCO frequency is stepped down in 5 KHz steps which steps the 20/30 frequency from 30 MHz down to 29.990 MHz in 1 kHz steps. Since the M/N frequency remains constant and the 8340A output frequency is mixed with a harmonic (13th) of the M/N signal and the resultant output is phase compared to the 20/30 output, the 8340A output frequency must increase by 1 kHz/step to satisfy the 20/30 phase lock loop. This checks the least significant (BCD) N2 programming bits.

To observe the N2 PLL2 VCO frequency changes, repeat the N2 loop frequency check (Step 6a through 6c) pressing [SHIFT] [M3] in step 6b rather than [SHIFT] [M1]. [SHIFT] [M3] will display, from left to right, the PLL2 VCO frequency and the PLL3 Up Converter frequency (the PLL3 Up Converter frequency display will be 0 since the PLL3 is not used in the swept mode).

- d. Select a step size of 10 kHz by pressing [SHIFT] [CF] [1] [0] [kHz]. Press [CF] to display the center frequency in the [ENTRY DISPLAY]; the display should indicate 2.310510 GHz.
- e. Using the up arrow key, step the center frequency up to 2.310600 GHz. Check the counter indication at each step. The counter should indicate the 8340A start frequency ($CF - 0.0005 \text{ GHz}$) $\pm 1 \text{ Hz} \pm$ the resolution of the counter.

NOTE

The above steps program the 20/30 frequency from 29.99 MHz to 29.90 MHz in 0.01 MHz steps and checks additional N2 Divider programming bits.

- f. Select a step size of 100 kHz by pressing [SHIFT] [CF] [1] [0] [0] [kHz]. Press [CF] to display the center frequency in the [ENTRY DISPLAY]. The CF should be at 2.310600 GHz.
- g. Using the up arrow key, step the center frequency up to 2.311500 GHz. Check the counter indication at each step. The counter should indicate the 8340A start frequency ($CF - 0.0005 \text{ GHz}$) $\pm 1 \text{ Hz} \pm$ the resolution of the counter.

NOTE

The above steps program the 20/30 frequency from 29.9 to 29.0 in 0.1 MHz steps and check additional N2 Divider programming bits.

4-10. FREQUENCY RANGE AND CW MODE ACCURACY (Cont'd)

- h. Select a step size of 1 MHz (i.e., press blue **[SHIFT]** key and then **[CF]** key and enter **[1] [MHz]**). Press **[CF]** to display the center frequency in the **[ENTRY DISPLAY]**. The CF should be at 2.311500 GHz.
- i. Using the up arrow key, step the center frequency up to 2.320500 GHz. Check the counter indication at each step. The counter should indicate the 8340A start frequency (CF – 0.0005 GHz) ± 1 Hz \pm the resolution of the counter.

NOTE

The above steps program the 20/30 frequency from 29.0 MHz to 21.0 MHz in 1 MHz steps. The last CF step programs the 20/30 to 30 MHz and the M/N frequency to 180.769231 MHz. This checks the remaining N2 Divider programming bits.

- j. If a significant frequency error is evident, note the conditions under which the error occurred and continue this procedure to determine if any other conditions produce an error.
7. Check the 20/30 MHz N1 loop frequencies as follows:
- a. Press **[INSTR PRESET]**. Select a step size of 10 kHz by pressing **[SHIFT] [CF] [1] [0] [kHz]**. Press **[CW]** and enter **[2] [3] [1] [9] [.] [9] [7] [MHz]**.
 - b. Press **[SHIFT] [M1]** to display, from left to right, the M divide number, the N divide number, the M/N Output frequency, and the 20/30 Output frequency.
 - c. Using the down arrow key, step the CW frequency down to 2 319.870000 MHz. Check the counter indication at each step. The counter should indicate the 8340A CW frequency ± 1 Hz \pm the resolution of the counter.

NOTE

The above steps set the output of the M/N loop to 180 MHz where M=26 and N=13. The PLL1 VCO frequency is stepped up in 100 kHz steps. This steps the 20/30 frequency up from 20.03 MHz in 10 kHz steps to 20.13 MHz. The M/N frequency remains constant and the YO frequency is mixed with a harmonic (13th) of the M/N signal. The resultant output is phase compared to the 20/30 output. The 8340A output frequency must decrease by 10 kHz/step to satisfy the YO phase lock loop. This checks the least significant N1 programming bits.

- d. Select a step size of 100 kHz by pressing **[SHIFT] [CF] [1] [0] [0] [kHz]**. Press the **[CW]** key to view the CW frequency in the **[ENTRY DISPLAY]**. The CW frequency should be at 2319.870000 MHz.
- e. Using the down arrow key, step the CW frequency down to 2 318.970000 MHz. Check the counter indication at each step. The counter should indicate the 8340A CW frequency ± 1 Hz \pm the resolution of the counter.

4-10. FREQUENCY RANGE AND CW MODE ACCURACY (Cont'd)**NOTE**

The above steps program the 20/30 frequency from 20.13 up to 21.03 in 0.1 MHz steps and checks additional N1 Divider programming bits.

- f. Select a step size of 1 MHz by pressing **[SHIFT] [CF] [1] [MHz]**. Press the **[CW]** key to view the CW frequency in the **[ENTRY DISPLAY]**. The CW frequency should be at 2318.970000 MHz.
- g. Using the down arrow key, step the CW frequency down to 2310.970000 MHz. Check the counter indication at each step. The counter should indicate the 8340A CW frequency $\pm 1 \text{ Hz} \pm$ the resolution of the counter.

NOTE

The above steps program the 20/30 frequency from 21.03 MHz to 29.03 MHz in 1 MHz steps and check the remaining N1 Divider programming bits.

8. If frequency errors occurred, determine what frequency related circuit is most likely to have caused the symptom (i.e., M/N Loop or 20/30 Loop) then refer to the appropriate troubleshooting Functional Group in Section VIII, Service.

4-11. SWEEP TIME ACCURACY

Specification

Table 4-4. Sweep Time Accuracy Specifications

| |
|---|
| Range: 10 milliseconds to 200 seconds forward sweep times Accuracy: $\pm 5\%$ (sweeptimes ≤ 50 seconds) |
|---|

Description

The 8340A is swept from 3 GHz to 7 GHz at 6 different sweep times, ranging from 10 ms to 200 sec. The rear panel STOP SWEEP IN/OUT signal of the 8340A is used to trigger INPUT A and B on an HP 5316A Universal Counter used in the time interval mode. At the start of a sweep, the STOP SWEEP IN/OUT signal changes from TTL low to TTL high. This pulse triggers INPUT A on the Universal Counter (selected for leading edge triggering) and the count begins. At the end of a sweep, the STOP SWEEP IN/OUT signal changes from TTL high to TTL low. At this point, INPUT B is triggered (selected for trailing edge triggering) and the count is complete. After the Universal Counter has made several counts, an accurate reading of the 8340A sweep time is indicated on its display.

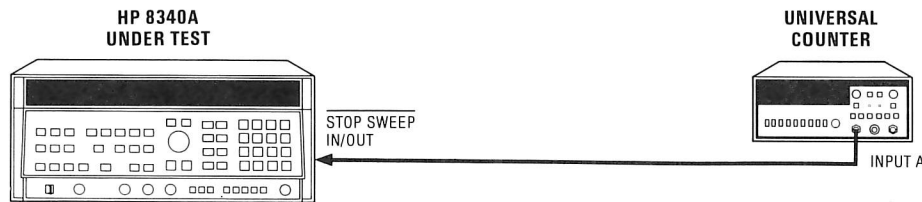

Figure 4-3. Sweep Time Accuracy Test Setup

Equipment

Universal Counter HP 5316A

Procedure

1. Connect equipment as shown in Figure 4-3. Switch the 8340A POWER to ON. Allow the equipment to warm up for 30 minutes.
2. On the 8340A, press [INSTR PRESET] [START FREQ] [3] [GHz] [STOP FREQ] [7] [GHz] [POWER LEVEL] [0] [dBm].

4-11. SWEEP TIME ACCURACY (Cont'd)

3. Set up the 5316A as follows:

TI A→B IN
 GATE TIME MIN
 LEVEL/SENSE (CHANNEL A and B) +MAX
 TRIGGER (CHANNEL A and B) LEVEL
 AC/DC (CHANNEL A and B) DC
 ATTN (CHANNEL A and B) X1
 FILTER NORM
 SEP/COM A COM A
 Channel A Triggering Leading Edge
 Channel B Triggering Trailing Edge

NOTE

To ensure that an accurate sweep time indication is obtained from the HP 5316A in step 4, allow the HP 8341A to complete at least three sweeps.

4. On the HP 8340A, press [SWEEP TIME][1][0][msec]. Verify that the sweep time displayed by the HP 5316A is within the limits shown in Table 4-5.
5. Repeat step 4 for values shown in Table 4-5.

Table 4-5. Sweep Time Accuracy Limits

| Selected | Lower Limit | Upper Limit |
|----------|-------------|-------------|
| 10 msec | 9.5 msec | 10.5 msec |
| 100 msec | 95 msec | 105 msec |
| 1 sec | .95 sec | 1.05 sec |
| 10 sec | 9.5 sec | 10.5 sec |
| 50 sec | 47.5 sec | 52.5 sec |

4-12. SWEEP FREQUENCY ACCURACY**Specification***Table 4-6. Swept Frequency Accuracy Specifications*

| |
|--|
| <p>Center Frequency/Sweep Width Mode (CF/ΔF)</p> <p>Readout Accuracy with respect to sweep out voltage (sweep time > 100 milliseconds):</p> <p>$\Delta F \leq n \times 5 \text{ MHz}$: $\pm 1\%$ of indicated sweep width (ΔF) \pm time base accuracy*</p> <p>$\Delta F > n \times 5 \text{ MHz}$ to $< 300 \text{ MHz}$: $\pm 2\%$ of indicated sweep width (ΔF)</p> <p>$\Delta F \geq 300 \text{ MHz}$: $\pm 1\%$ of indicated sweep width (ΔF), or $\pm 50 \text{ MHz}$, whichever is less</p> <p>Where n = harmonic multiplication number (1 to 4). Refer to Frequency Ranges and Bandswitch Points description in Table 1-1.</p> <p>* Time Base affects Center Frequency accuracy only, not Sweep Width Accuracy.</p> <p>Start/Stop Mode</p> <p>Readout Accuracy with respect to sweep out voltage (sweep time > 100 milliseconds):</p> <p>Same as Center Frequency/Sweep Width Mode.</p> |
|--|

Description

The HP 8340A (DUT) RF output is connected to the HP 8566A Spectrum Analyzer input. The spectrum analyzer is set for zero Hz span at a CW frequency within the HP 8340A swept frequency range. The spectrum analyzer VIDEO OUT (applied to the oscilloscope vertical input) will have a response as the HP 8340A output passes through the frequency that the spectrum analyzer is tuned to. The selected spectrum analyzer bandwidth filter will determine the shape of the response.

The HP 8340A SWEEP OUT, in series with a power supply, is applied to an oscilloscope's horizontal input. The input to the oscilloscope is clamped at $\pm 0.7\text{V}$ by two diodes to prevent overdriving the oscilloscope's input. The oscilloscope is calibrated by setting the HP 8340A and the spectrum analyzer to the same CW frequency (e.g., 20% of Band). To set the HP 8340A to have a SWEEP OUT voltage and at the same time a phase locked CW frequency that is proportional to a percentage of a swept frequency band, the START and STOP frequencies are selected, MANUAL SWEEP is selected, and a frequency equivalent to the desired percentage of band is selected (e.g., START 3 GHz, STOP 5 GHz, MANUAL 3.4 GHz, for 20%). The power supply is adjusted for a DVM indication of zero volts and the oscilloscope horizontal position control is used to position the dot to the center graticule line. With the oscilloscope horizontal sensitivity set to 0.05 V/Division, the CRT horizontal axis is now calibrated to approximately 0.5% of the swept frequency range per division. The spectrum analyzer VIDEO OUT voltage to the oscilloscope is then maximum and the scope vertical position is adjusted to place the dot near the top of the CRT.

The HP 8340A can now be set to sweep any frequency range and the oscilloscope center graticule line will represent the calibrated percentage (e.g., 20%) of the sweep range. The

4-12. SWEEP FREQUENCY ACCURACY (Cont'd)

spectrum analyzer center frequency is set to a frequency that is the desired percentage (e.g., 20%) of the 8340A swept frequency range. If the 8340A swept frequency accuracy is perfect, the oscilloscope trace will be the response of the spectrum analyzer's bandwidth filter, centered on the CRT. If the trace is not centered, the spectrum analyzer center frequency is adjusted to position the response to the center of the oscilloscope CRT. The amount of spectrum analyzer frequency change is the 8340A Swept Frequency Accuracy error.

Since the circuitry that determines swept frequency accuracy is the same for both ΔF Mode and Start/Stop Mode, only Start/Stop Mode swept frequency accuracy is tested.

NOTE

The spectrum analyzer resolution bandwidth, and 8340A sweep time must be compatible to obtain the desired oscilloscope response.

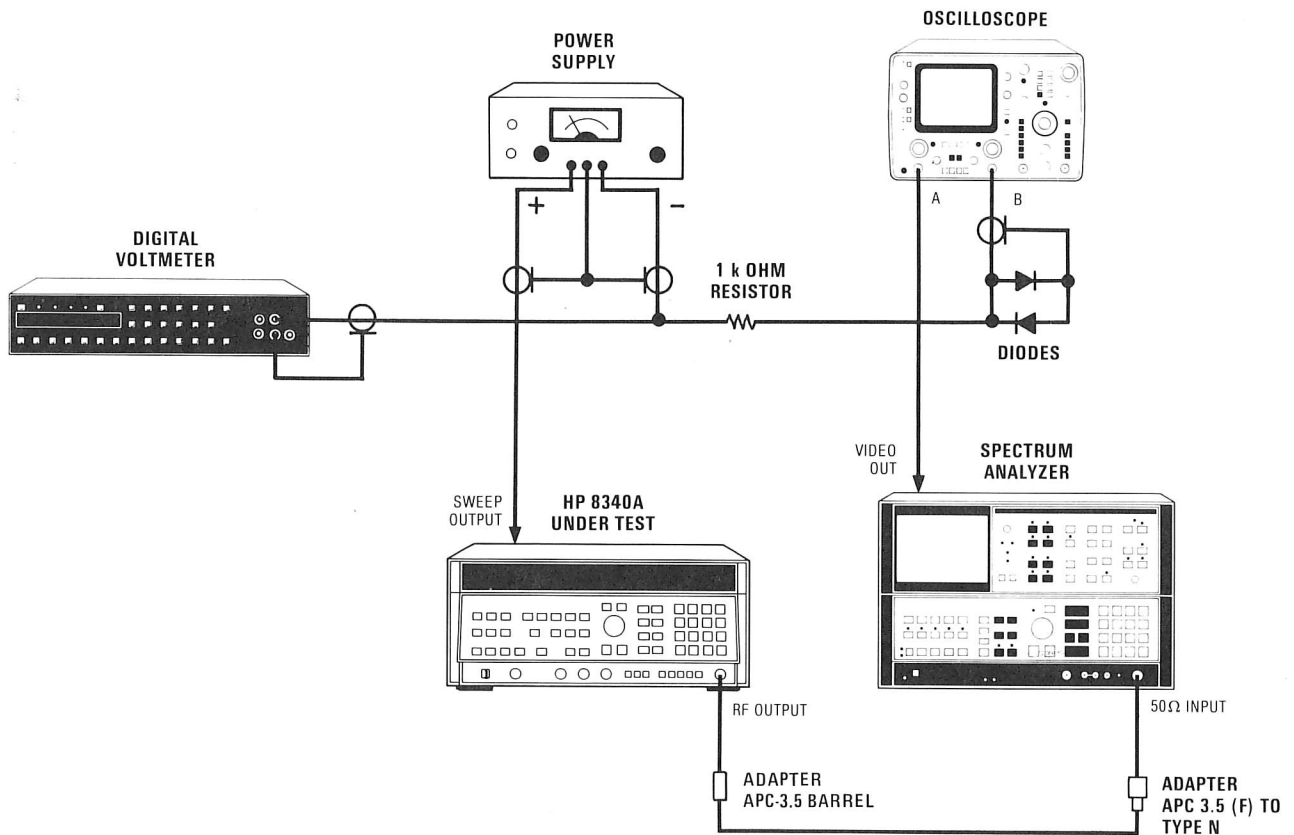

Figure 4-4. Swept Frequency Accuracy Test Setup

4-12. SWEPT FREQUENCY ACCURACY (Cont'd)

Equipment

| | |
|--|------------------|
| Spectrum Analyzer..... | HP 8566A |
| Oscilloscope..... | HP 1741A |
| Power Supply..... | HP 6294A |
| Adapter..... HP P/N 5061-5311 APC-3.5 (female) to APC 3.5 (female) | |
| Adapter..... HP P/N 1250-1743 Type N (male) to APC 3.5 (male) | |
| Cable..... HP P/N 08340-20124 (SMA male to SMA male) | |
| Diode (2 required)..... | HP P/N 1901-0028 |
| Digital Voltmeter..... | HP 3455A |
| 1 KOhm Resistor..... | HP P/N 0757-0280 |

Procedure

1. Connect the equipment as shown in Figure 4-4 (with the power supply output set to 0 Vdc). Allow the equipment to warm up for one hour.
2. Press 8340A [**INSTR PRESET**]. Set the oscilloscope to display amplitude versus sweep out voltage (A vs B). Set channel A sensitivity to 0.2V/Div.
3. Set the spectrum analyzer REFERENCE LEVEL to 20 dBm. Set CENTER FREQUENCY to 3.4 GHz for 20% (4 GHz for 50%, or 4.6 GHz for 80%). Set FREQUENCY SPAN to zero. Set RES BW (resolution bandwidth) to 3 MHz.
4. Set 8340A to have a sweep out voltage and at the same time, a phase locked CW frequency that is proportional to a percentage of band as follows:
 - a. Press [**START**] and enter [**3**] [**GHz**]
 - b. Press [**STOP**] and enter [**5**] [**GHz**].
 - c. Press [**MANUAL**] SWEEP and enter [**3**] [**.**] [**4**] [**GHz**] for 20% (4 GHz for 50%, or 4.6 GHz for 80%).

CAUTION

Do not adjust the power supply for greater than ±10 Vdc in this procedure.

5. Adjust the oscilloscope's Channel B sensitivity for 0.05 V/DIV and the horizontal position control for midrange. Adjust the power supply voltage for a DVM indication of 0 ±10 mVdc.
6. Adjust oscilloscope horizontal position control to position the dot on the center graticule. Adjust the oscilloscope vertical position to place the dot near the top of the CRT.

NOTE

The oscilloscope is now calibrated for 0.5%/Division and for the desired percentage of band (i.e., 20%, 50%, or 80%). Measurements can now be made at this percentage of band for any Start/Stop frequency and any frequency span.

4-12. SWEPT FREQUENCY ACCURACY (Cont'd)

Table 4-7. Swept Frequency Accuracy Test Frequencies

| 8340A | | | Spectrum Analyzer | | | | Test Limit (kHz) |
|------------------|-----------------|-----------------|------------------------|-------------|-------------|--------------|------------------|
| Start Freq (GHz) | Stop Freq (GHz) | Sweep Time (ms) | Center Frequency (GHz) | | | Res BW (kHz) | |
| | | | 20% of Band | 50% of Band | 80% of Band | | |
| 2.3 | 2.300099 | 3000 | 2.3000198 | 2.3000495 | 2.300792 | 0.3 | ± 0.99 |
| 2.3 | 2.300101 | 3000 | 2.3000202 | 2.3000505 | 2.3000808 | 0.3 | ± 1.01 |
| 2.3 | 2.300499 | 1000 | 2.3000998 | 2.3002495 | 2.3003992 | 1.0 | ± 4.99 |
| 2.3 | 2.300501 | 1000 | 2.3001002 | 2.3002505 | 2.3004008 | 1.0 | ± 5.01 |
| 2.3 | 2.30499 | 300 | 2.300998 | 2.302495 | 2.303992 | 3.0 | ± 49.9 |
| 2.3 | 2.30501 | 300 | 2.301002 | 2.302505 | 2.304008 | 3.0 | ± 100.02 |
| 2.3 | 2.31 | 300 | 2.302 | 2.305 | 2.308 | 3.0 | ± 200 |
| 2.3 | 2.32 | 100 | 2.304 | 2.310 | 2.316 | 10 | ± 400 |
| 2.3 | 2.33 | 100 | 2.306 | 2.315 | 2.324 | 10 | ± 600 |
| 2.3 | 2.34 | 100 | 2.308 | 2.320 | 2.332 | 30 | ± 800 |
| 2.3 | 2.349 | 100 | 2.3098 | 2.3245 | 2.3392 | 30 | ± 998 |
| 2.3 | 2.3501 | 100 | 2.31002 | 2.32505 | 2.34008 | 30 | ± 1020 |
| 2.3 | 2.36 | 100 | 2.312 | 2.33 | 2.348 | 30 | ± 1200 |
| 2.3 | 2.37 | 100 | 2.314 | 2.335 | 2.356 | 30 | ± 1400 |
| 2.3 | 2.38 | 100 | 2.316 | 2.34 | 2.364 | 30 | ± 1600 |
| 2.3 | 2.39 | 100 | 2.318 | 2.345 | 2.372 | 30 | ± 1800 |
| 2.3 | 2.3999 | 100 | 2.31998 | 2.34995 | 2.37992 | 30 | ± 1980 |
| 2.3 | 2.4001 | 100 | 2.32002 | 2.35005 | 2.38008 | 100 | ± 2002 |
| 2.3 | 2.799 | 100 | 2.3998 | 2.5495 | 2.6992 | 1000 | ± 4990 |
| 2.3 | 2.801 | 100 | 2.4002 | 2.5505 | 2.7008 | 1000 | ± 5010 |
| 2.3 | 7.29 | 100 | 3.298 | 4.795 | 6.292 | 3000 | ± 49900 |
| 2.3 | 7.31 | 100 | 3.302 | 4.805 | 6.308 | 3000 | ± 50000 |
| 2.3 | 8.3 | 100 | 3.500 | 5.300 | 7.100 | 3000 | ± 50000 |
| 2.3 | 16.452 | 100 | 5.1304 | 9.376 | 13.6216 | 3000 | ± 50000 |
| 2.3 | 24.55 | 100 | 6.75 | 13.425 | 20.1 | 3000 | ± 50000 |
| 2.3 | 26.5 | 100 | 7.14 | 14.4 | 21.66 | 3000 | ± 50000 |

7. Refer to Table 4-7, press the 8340A [START FREQ] key and enter the start frequency shown in Table 4-7. Press the [STOP FREQ] key and enter the appropriate stop frequency. Press the [SWEEP TIME] key and enter the appropriate sweep time. Select the appropriate spectrum analyzer resolution bandwidth. Set the spectrum analyzer center frequency to the appropriate frequency for the percentage of band being tested. Press the 8340A [CONT] key to return the 8340A to the swept mode.
8. Ideally, the oscilloscope response will be at the center graticule line, if not, adjust the spectrum analyzer center frequency to bring the oscilloscope response to the center graticule line. The difference between the original center frequency setting and present center frequency is the 8340A swept frequency error. This error should be within the test limit shown in Table 4-7.
9. Repeat steps 3 through 8 to test at 50% and 80% of band.

NOTE

If the swept frequency accuracy error exceeds the test limit, refer to the Sweep Gain and Delay Adjustments in Section V, Adjustments.

4-13. MAXIMUM LEVELED OUTPUT POWER AND POWER ACCURACY TEST

Specification

Table 4-8. Maximum Leveled Output Power and Power Accuracy Specifications (1 of 2)

| MAXIMUM LEVELED POWER (0°C to +35°C) | Bands and Approximate Frequency Ranges (GHz) (see Frequency Ranges and Bandswitch Points for complete description) | | | | | |
|--|---|--|--------------|---------------|--|--------------|
| | Band 0 | Band 1 | Band 2 | Band 3 | Band 4 | |
| | 0.01 to <2.3 | 2.3 to <7.0 | 7.0 to <13.5 | 13.5 to <20.0 | 20.0 to <23.0 | 23.0 to 26.5 |
| STANDARD INSTRUMENT | +10.0 dBm | +12.0 dBm | +10.0 dBm | +9.0 dBm | +3.0 dBm | +1.0 dBm |
| OPTION 001 (F.P. Out w/o Atten.) | +10.0 dBm | +13.0 dBm | +12.0 dBm | +11.0 dBm | +6.0 dBm | +4.0 dBm |
| OPTION 004 (R.P. Out w/Atten.) | +10.0 dBm | +11.0 dBm | +9.0 dBm | +7.0 dBm | +1.0 dBm | -1.0 dBm |
| OPTION 005 (R.P. Out w/o Atten.) | +10.0 dBm | +12.0 dBm | +11.0 dBm | +9.0 dBm | +4.0 dBm | +2.0 dBm |
| OUTPUT POWER ACCURACY ¹ | Bands and Approximate Frequency Ranges (GHz) (see Frequency Ranges and Bandswitch Points for complete description) | | | | | |
| | Band 0 0.01 to < 2.3 | Bands 1-3 2.3 to <20 | | | Band 4 20 to 26.5 | |
| STANDARD INSTRUMENT +18 to +10 dBm ² +10 to -9.95 dBm -10 to -19.95 dBm -20 to -49.95 dbm -50 to -79.95 dBm -80 to -100 dBm | — ± 0.9 dB ± 1.2 dB ± 1.5 dB ± 1.8 dB ± 2.1 dB | ± 1.8 dB ± 1.5 dB ± 2.0 dB ± 2.3 dB ± 2.6 dB ± 2.9 dB | | | ± 2.3 dB ± 2.0 dB ± 2.5 dB ± 2.8 dB ± 3.1 dB ± 3.4 dB | |
| OPTION 004 (Rear Panel Output w/Atten.) +18 to +10 dBm ² +10 to -11.95 dBm -12 to -21.95 dBm -22 to -51.95 dBm -52 to -81.95 dBm -82 to -100 dBm | — ± 1.0 dB ± 1.3 dB ± 1.6 dB ± 1.9 dB ± 2.2 dB | ± 2.0 dB ± 1.7 dB ± 2.2 dB ± 2.5 dB ± 2.8 dB ± 3.1 dB | | | ± 2.5 dB ± 2.2 dB ± 2.7 dB ± 3.0 dB ± 3.3 dB ± 3.6 dB | |
| OPTION 001 (Front Panel Output w/o Atten.) +18 to +10 dBm ² +10 to -10 dBm -10 to -20 dBm | — ± 0.9 dB ± 1.7 dB | ± 1.6 dB ± 1.3 dB ± 2.1 dB | | | ± 2.0 dB ± 1.7 dB ± 2.5 dB | |
| OPTION 005 (Rear Panel Output w/o Atten.) +18 to +10 dBm ² +10 to -10 dBm -10 to -20 dBm | — ± 1.0 dB ± 1.8 dB | ± 1.8 dB ± 1.5 dB ± 2.3 dB | | | ± 2.2 dB ± 1.9 dB ± 2.7 dB | |

**4-13. MAXIMUM LEVELED OUTPUT POWER AND POWER ACCURACY TEST
(Cont'd)**

Table 4-8. Maximum Leveled Output Power and Power Accuracy Specifications (2 of 2)

| FLATNESS (Internally leveled) | | | |
|--|---|--|--|
| STANDARD INSTRUMENT | Band 0 0.01 to <2.3 | Bands 1–3 2.3 to <20 | Band 4 20 to 26.5 |
| +18 to +10 dBm ² +10 to -9.95 dBm -10 to -19.95 dBm -20 to -49.95 dBm -50 to -79.95 dBm -80 to -100 dBm | — ± 0.6 dB ± 0.9 dB ± 1.2 dB ± 1.4 dB ± 1.7 dB | ± 1.2 dB ± 1.1 dB ± 1.6 dB ± 1.9 dB ± 2.2 dB ± 2.5 dB | ± 1.7 dB ± 1.6 dB ± 2.1 dB ± 2.4 dB ± 2.7 dB ± 3.0 dB |
| OPTION 004 (Rear Panel Output w/Atten.) +18 to +10 dBm ² +10 to -11.95 dBm -12 to -21.95 dBm -22 to -51.95 dBm -52 to -81.95 dBm -82 to -100 dBm | — ± 0.7 dB ± 1.0 dB ± 1.3 dB ± 1.5 dB ± 1.8 dB | ± 1.4 dB ± 1.3 dB ± 1.8 dB ± 2.1 dB ± 2.4 dB ± 2.7 dB | ± 1.9 dB ± 1.8 dB ± 2.3 dB ± 2.6 dB ± 2.9 dB ± 3.2 dB |
| OPTION 001 (Front Panel Output w/o Atten.) +18 to +10 dBm ² +10 to -10 dBm -10 to -20 dBm | — ± 0.6 dB ± 0.8 dB | ± 1.0 dB ± 0.9 dB ± 1.5 dB | ± 1.4 dB ± 1.3 dB ± 1.9 dB |
| OPTION 005 (Rear Panel Output w/o Atten.) +18 to +10 dBm ² +10 to -10 dBm -10 to -20 dBm | — ± 0.7 dB ± 0.9 dB | ± 1.2 dB ± 1.1 dB ± 1.7 dB | ± 1.6 dB ± 1.5 dB ± 2.1 dB |
| NOTES | | | |
| <ol style="list-style-type: none"> 1. Internally leveled, AM off. The POWER dBm display monitors the actual output power, giving accurate readings when unleveled, externally leveled, or when amplitude modulating with a signal that has a dc component. The ENTRY DISPLAY shows the desired power level, or the desired external detector output voltage, exclusive of modulation. 2. The ALC loop typically operates up to +20 dB to enhance usability at those frequencies where leveled power greater than the maximum specified is available. | | | |

4-13. MAXIMUM LEVELED OUTPUT POWER AND POWER ACCURACY TEST (Cont'd)

Description

MAXIMUM LEVELED POWER

For maximum leveled power, a crystal detector and an oscilloscope are used to monitor the swept response. The 8340A is set to sweep a given frequency band. The power level is increased until the 8340A UNLEVELED indicator comes on, then decreased until the UNLEVELED indicator just goes out. The maximum leveled power may differ with sweep mode and sweep time. To find the worst case, the maximum leveled power is checked in three modes: single sweep with auto sweep time, single sweep with a two second sweep time, and continuous sweep. The worst case mode is selected, and a frequency marker is positioned at the minimum power point on the swept display. The 8340A is set to CW at the marker frequency and the power is measured using a power meter. The power meter indication should be greater than or equal to the maximum leveled power specification. This procedure is repeated for each frequency band.

FLATNESS

Flatness is measured with the RF output level at 0 dBm. Flatness is primarily a function of the RF path; therefore, the response will be essentially the same at all ALC levels. However, the response will most likely change when the RF Attenuator is stepped to a different attenuation level. (An automated test is available to adjust the RF attenuator correction factors and verify attenuator flatness; refer to Automated Test Procedures, following this section.)

A power meter is used to measure the RF signal level. An oscilloscope, connected to the power meter recorder output, is used to find the frequencies where the maximum and minimum points of the response occur. The 8340A is set to a slow sweep to allow the power meter to respond to any power variations. A marker is positioned at the maximum and minimum points on the oscilloscope display. The 8340A is then set to CW at each of the marker frequencies and the power indications are recorded. The maximum power level minus the minimum power level should be within the flatness specification.

ACCURACY

The absolute power level at the maximum and minimum points should be within the accuracy specification.

4-13. MAXIMUM LEVELED OUTPUT POWER AND POWER ACCURACY TEST (Cont'd)

Two different Power Sensors may be required to cover the complete frequency range. The HP 8481A Power Sensor is used from 10 MHz to 50 MHz and the HP 8485A Power Sensor is used for the other frequency bands covering 50 MHz to 26.5 GHz. The 8485A Power Sensor can be used down to 10 MHz, but if a minimum or maximum that is close to the test limits occurs in this frequency range, the 8481A Power Sensor should be used.

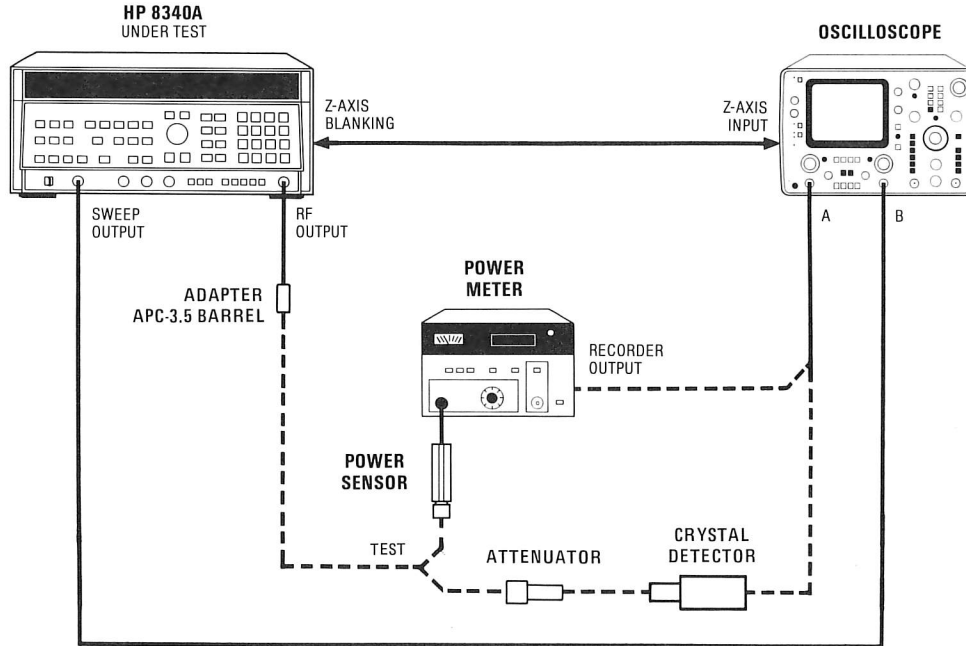

Figure 4-5. Maximum Leveled Output Power and Power Accuracy Test Setup.

Equipment

| | |
|--|-------------------|
| Oscilloscope..... | HP 1741A |
| Attenuator | HP 8493C Opt. 010 |
| Crystal Detector | HP 33330C |
| Power Meter..... | HP 436A |
| Power Sensor..... | HP 8481A |
| Power Sensor..... | HP 8485A |
| Adapter (APC-3.5 female to female) | HP P/N 5061-5311 |

Procedure

MAXIMUM LEVELED POWER

1. Connect the equipment as shown in Figure 4-5. Connect the 10 dB pad and crystal detector to the 8340A RF output and connect the detector output to the oscilloscope channel A input. Allow at least 30 minutes warm up time.
2. Press **[INSTR PRESET]**. Press **[PEAK]** on. Press **[STOP FREQUENCY]** and enter **[2] [.] [3] [GHz]**. Adjust the oscilloscope to view the swept output of the crystal detector.

In Band 0 (10 Mhz to 2.3 GHz), the crystal detector may pass a portion of the RF signal. This RF feedthrough may be visible on the low frequency portion of the oscilloscope trace.

4-13. MAXIMUM LEVELED OUTPUT POWER AND POWER ACCURACY TEST (Cont'd)

Also, as the power in Band 0 is increased toward maximum leveled, the level of the harmonics may increase and cause a perturbation in the swept response. This will cause the maximum power indication on the oscilloscope to increase without causing the UNLEVELED indicator to light. Therefore, flatness is only specified at $\leq +10$ dBm in Band 0.

3. Press the **[POWER LEVEL]** key and, using the front panel rotary knob, increase the power level until the UNLEVELED indicator comes on. Slowly decrease the power level until the UNLEVELED indicator just goes off. Note the ENTRY DISPLAY power indication.

NOTE

The maximum leveled power indication may differ with sweep mode and sweep time. To find the worst case, the maximum leveled power is checked in continuous sweep with auto sweep time (step 3), single sweep with auto sweep time (step 4), and single sweep with a two second sweep time (step 5).

4. Press **[SINGLE SWEEP]** repeatedly and repeat step 3.
5. Press **[SWEEP TIME]** and enter **[2] [sec]**. Repeat step 3.
6. Select the 8340A mode that gave the worst case maximum leveled power indication (lowest ENTRY DISPLAY indication). Press **[M2]** and position the marker, using the rotary knob, to the minimum power level point on the oscilloscope trace (for a negative polarity crystal detector, this is the highest point on the display, for a positive polarity detector, this is the lowest point on the display). Using the oscilloscope vertical position control, position the marker on a horizontal graticule line. Note the marker frequency. Press **[MANUAL]** and enter the frequency noted for M2. Due to SYTM tracking, the RF output level at a single frequency may be greater than in a swept mode; therefore, if the oscilloscope now indicates a higher power level than the swept response (for a positive polarity detector, the trace moves down), press **[POWER LEVEL]** and using the rotary knob adjust the power level to return the dot on the oscilloscope to the horizontal reference line for the minimum swept power point.
7. Disconnect the 10 dB pad and crystal detector and connect the Power Sensor to the 8340A RF output. Set the Power Meter's calibration factor switch to include the frequency noted for M2.

To obtain the most accurate Power Meter reading, zero the Power Meter on the range being used. To zero the Power Meter, press the Power Meter RANGE HOLD, press 8340A **[RF]** off, zero the Power Meter, and press **[RF]** on.

The Power Meter indication should be equal to or greater than the maximum leveled power specification. If the 8340A does not meet its maximum leveled power specification, refer to SRD Bias and SYTM Tracking adjustments in Section V.

8. Press the **[START FREQ]** key and enter the start frequency for the next band. Press the **[STOP FREQUENCY]** key and enter the stop frequency for the next band. Repeat steps 3 through 7 until all frequency bands have been checked.

4-13. MAXIMUM LEVELED OUTPUT POWER AND POWER ACCURACY TEST (Cont'd)

FLATNESS

9. Flatness is measured with the RF output level at 0 dBm. Flatness is primarily a function of the RF path; therefore, the response will be essentially the same at all ALC levels. Although the ALC accuracy is not specified separately, the ALC accuracy is typically <0.15 dB for RF output levels from +10 dBm to -9.95 dBm.

To test ALC accuracy, step the 8340A RF power in 1 dB steps from +10 to -9.95 dBm (note, for instruments with front panel RF output, that as the power steps from -9.95 to -10 dBm, the RF attenuator is set to 10 dB and the ALC is set to 0 dBm). If the power meter indication is >0.15 dB from the ENTRY DISPLAY indication, refer to the ALC adjustments in Section V.

If the ALC accuracy is tested, frequency response must be considered; therefore, use the 0 dBm power meter indication as a reference.

Also it should be noted that the power level in the ENTRY DISPLAY is the requested power level. In normal ALC modes, the instrument processor duplicates the ENTRY DISPLAY power level in the POWER dBm display with 0.1 dB resolution; however, if AM is selected, the processor reads the ALC level with an A/D converter, calculates the associated power level, and displays the calculated value in the POWER dBm display.

10. Press [INSTR PRESET]. Press [PEAK] on. Press [STOP FREQUENCY] and enter [2] [.] [3] [GHz]. Press [POWER LEVEL] and enter [0] [dBm].
11. Press the [SWEEP TIME] key and enter [2] [sec].
12. Adjust the oscilloscope controls to view the Power Meter RECORDER OUTPUT voltage versus the 8340A SWEEP OUTPUT voltage (A versus B). The oscilloscope vertical gain and position must be changed as a function of the power meter range and RECORDER OUTPUT voltage.
13. Press Frequency Marker key [M2] and, using the rotary knob, vary the marker frequency to position the (intensified) marker on the lowest point on the oscilloscope trace. It may be necessary to adjust the oscilloscope INTENSITY to view the marker dot.
14. Note the marker frequency. Press the [MANUAL] key and enter the frequency noted for M2. Reset the power meter calibration factor switch to include this frequency. The power meter indication is the minimum power point. Record the power meter indication on the work sheet provided in Table 4-9.

NOTE

For Band 0 (10 MHz to 2.3 GHz), if the minimum or maximum power occurred below 50 MHz, use the 8481A Power Sensor to measure the power level.

Table 4-9. Maximum Leveled Output Power Test Work Sheet

| | | |
|--|-----------------------------------|--|
| Frequency Range: 10 MHz to 2.3 GHz | | |
| | Power Meter Indication | 8340A Entry Display |
| Steps 13, 14 | Minimum _____ | _____ |
| Step 15 | Maximum _____ | _____ |
| Step 18 | Flatness: | |
| | Maximum – Minimum _____ | (≤1.0 dB, Standard) (≤1.2 dB, Option 004) (≤1.0 dB, Option 001) (≤1.2 dB, Option 005) |
| Frequency Range: 2.3 GHz to 7.0 GHz | | |
| | Power Meter Indication | 8340A Entry Display |
| Steps 13, 14 | Minimum _____ | _____ |
| Step 15 | Maximum _____ | _____ |
| Step 18 | Flatness: | |
| | Maximum – Minimum _____ | (≤2.2 dB, Standard) (≤2.6 dB, Option 004) (≤1.8 dB, Option 001) (≤2.2dB, Option 005) |
| Frequency Range: 7.0 GHz to 13.5 GHz | | |
| | Power Meter Indication | 8340A Entry Display |
| Steps 13, 14 | Minimum _____ | _____ |
| Step 15 | Maximum _____ | _____ |
| Step 18 | Flatness: | |
| | Maximum – Minimum _____ | (≤2.2 dB, Standard) (≤2.6 dB, Option 004) (≤1.8 dB, Option 001) (≤2.2 dB, Option 005) |
| Frequency Range: 13.5 GHz to 20.0 GHz | | |
| | Power Meter Indication | 8340A Entry Display |
| Steps 13, 14 | Minimum _____ | _____ |
| Step 15 | Maximum _____ | _____ |
| Step 18 | Flatness: | |
| | Maximum – Minimum _____ | (≤2.2 dB, Standard) (≤2.6 dB, Option 004) (≤1.8 dB, Option 001) (≤2.2 dB, Option 005) |
| Frequency Range: 20.0 GHz to 26.5 GHz | | |
| | Power Meter Indication | 8340A Entry Display |
| Steps 13, 14 | Minimum _____ | _____ |
| Step 15 | Maximum _____ | _____ |
| Step 18 | Flatness: | |
| | Maximum – Minimum _____ | (≤3.2 dB, Standard) (≤3.6 dB, Option 004) (≤2.6 dB, Option 001) (≤3.0 dB, Option 005) |

4-13. MAXIMUM LEVELED OUTPUT POWER AND POWER ACCURACY TEST (Cont'd)

15. Press the **[CONT]** key to return to the sweep mode. Press **[M1]** and, using the rotary knob, vary the marker frequency to position the marker on the highest point on the oscilloscope trace. Note the marker frequency. Press the **[MANUAL]** key and enter the frequency noted for M1. Reset the power meter calibration factor switch to include this frequency. The power meter indication is the maximum power point. Record the power meter indication on the work sheet.
16. Press the **[CONT]** key to return to the swept mode. Press the **[START FREQ]** key and enter the start frequency for the next frequency band. Press the **[STOP FREQ]** key and enter the stop frequency for the next frequency band.
17. Repeat steps 12 through 16 to measure the flatness until all frequency bands have been checked.
18. The maximum minus the minimum power meter indications should be within the flatness specifications. If the 8340A does not meet its flatness specification, refer to Flatness Adjustments in Section V.

ACCURACY

19. The absolute power level at the maximum and minimum points should be within the accuracy specification. This test may be repeated at other ALC power levels (+10 dBm to -9.95 dBm) to verify flatness and accuracy specifications over the ALC range.

4-14. EXTERNAL LEVELING

Specification

Table 4-10. External Leveling Specifications

XTAL: Allows the 8340A to be externally leveled by crystal detectors of positive or negative polarity.

METER: Allows power meter leveling with any HP power meter.

Range (XTAL or METER): 500 microvolts (−66 dBV) to 2.0 volts (+6 dBV)

Accuracy of voltage at EXT INPUT connector relative to the displayed level (leveling voltage is shown in ENTRY DISPLAY in dBV): ± 0.5 dB \pm 200 microvolts

Description

The 8340A external leveling circuit is designed to maintain a constant voltage at the EXT INPUT BNC. This is achieved by first selecting a voltage (in dBV) to which the EXT INPUT will be leveled. This establishes a reference voltage for the ALC. The voltage at the EXT INPUT is then routed through the external leveling circuitry to the ALC and compared to the reference. If a difference between the two voltages exist, the 8340A RF OUTPUT power will be adjusted to compensate for the difference.

The 8340A's external leveling circuit allows a positive or negative crystal detector to be used in the external leveling loop. A positive crystal detector (HP 33330C) is used in this test but a negative crystal detector may be substituted.

The 8340A XTAL Leveling mode is selected to verify the 8340A's external leveling specification. Nine different dBV values, ranging from +6 dBV to −66 dBV, are selected and the voltage accuracy at the EXT INPUT is checked with a DVM.

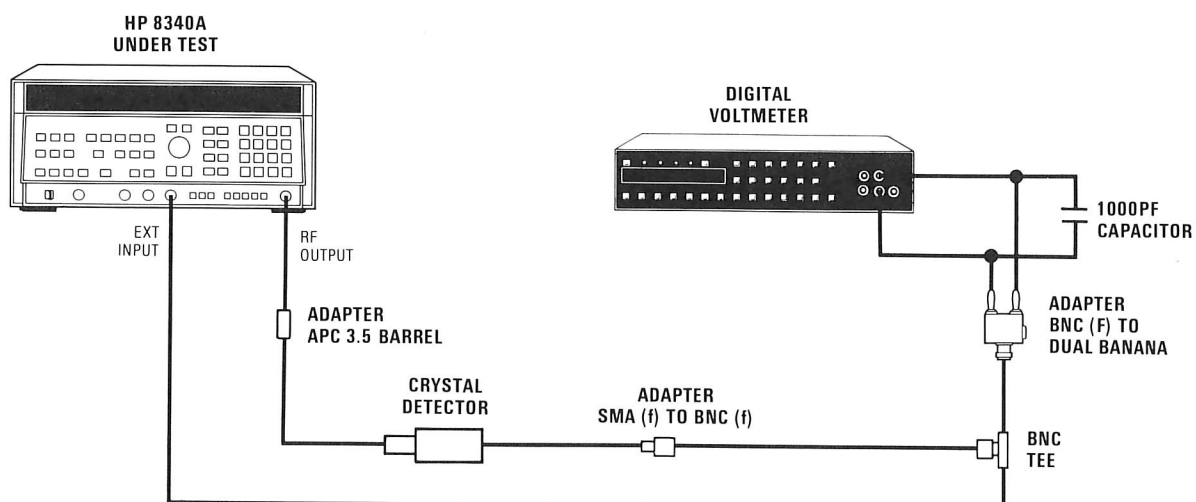

Figure 4-6. External Leveling Test Setup

4-14. EXTERNAL LEVELING (Cont'd)

Equipment

| | |
|--|-------------------|
| Digital Voltmeter (DVM) | HP 3455A |
| Crystal Detector | HP 33330C |
| Capacitor (1000 pF)..... | HP P/N 0160-4574 |
| Adapters | |
| APC 3.5 Barrel..... | HP P/N 5061-5311 |
| SMC(f) to BNC(f) | HP P/N 1250-0832 |
| BNC(f) to Dual Banana..... | HP P/N 1251-2277 |
| BNC Tee (m) (f) (f)..... | HP P/N 1250-0781 |
| Attenuators (required for Option 001 or Option 005 8340A only) | |
| 10 dB..... | HP 8493C Opt. 010 |
| 20 dB..... | HP 8493C Opt. 020 |

Procedure

1. Turn 8340A LINE switch ON. Press [INSTR PRESET] [CW] [4] [.] [5] [GHz] [POWER LEVEL] [0] [dB(m)].
2. Connect equipment as shown in Figure 4-6 (note 1000 pF capacitor shunting DVM input). Allow the equipment to warm up for 30 minutes.

NOTE

In step 3, XTAL mode is selected. In this mode, the [dB(m)] terminator key selects dBV. The dBV value selected corresponds to a voltage at which the 8340A EXT INPUT will be leveled (see Table 4-14). The selected dBV is displayed in the ENTRY DISPLAY.

NOTE

If a negative-polarity crystal detector is being used for this test, the voltages given in Tables 4-11, 4-12, 4-13, and 4-14 will all be negative.

3. Press [XTAL] [6] [dB(m)]. DVM reading should be within the values shown on the first line in Table 4-11.

Table 4-11. External Leveling Limits (With No Attenuator)

| dBV Selected | DVM Indication (V) | | |
|--------------|--------------------|--------|-------------|
| | Lower Limit | Ideal | Upper Limit |
| +6 | 1.883 | 1.995 | 2.114 |
| 0 | 0.944 | 1.000 | 1.059 |
| -10 | 0.2983 | 0.3162 | 0.3352 |
| -20 | 0.0942 | 0.1000 | 0.1061 |

4-14. EXTERNAL LEVELING (Cont'd)

4. Repeat Step 3 for the remaining dBV values shown in Table 4-11.
5. Press the down step key to select 10 dB of attenuation (Option 001 and 005 instruments do not include an internal attenuator. For these instruments install a 10 dB attenuator between the RF output and detector).
6. Repeat Step 3 for values shown in Table 4-12.

Table 4-12. External Leveling Limits (With 10 dB Attenuator)

| dBv Selected | DVM Indication (mV) | | |
|-----------------|---------------------|-------|-------------|
| | Lower Limit | Ideal | Upper Limit |
| -30 | 29.65 | 31.62 | 33.70 |
| -40 | 9.24 | 10.00 | 10.79 |

7. Press the down step key to select 20 dB of attenuation (for Option 001 or 005 instruments, remove 10 dB attenuator installed in step 5 and replace it with a 20 dB attenuator).
8. Repeat Step 3 for values shown in Table 4-13.

Table 4-13. External Leveling Limits (With 20 dB Attenuator)

| dBv Selected | DVM Indication (mV) | | |
|-----------------|---------------------|-------|-------------|
| | Lower Limit | Ideal | Upper Limit |
| -50 | 2.785 | 3.162 | 3.550 |
| -60 | 0.744 | 1.000 | 1.259 |
| -66 | 0.273 | 0.501 | 0.731 |

4-14. EXTERNAL LEVELING (Cont'd)

4-14. dBV vs. Voltage Reference Table

| dBV | Voltage | dBV | Voltage |
|------------|----------------|------------|----------------|
| 7 | 2.239V | -12 | 0.2512V |
| 6 | 1.995V | -19 | 0.1122V |
| 5 | 1.778V | -20 | 0.1000V |
| 4 | 1.585V | -21 | 89.13mV |
| 3 | 1.413V | -29 | 35.48mV |
| 2 | 1.259V | -30 | 31.62mV |
| 1 | 1.122V | -31 | 28.18mV |
| 0 | 1.000V | -39 | 11.22mV |
| -1 | 0.8913V | -40 | 10.00mV |
| -2 | 0.7943V | -41 | 8.913mV |
| -3 | 0.7079V | -49 | 3.548mV |
| -4 | 0.6310V | -50 | 3.162mV |
| -5 | 0.5623V | -51 | 2.818mV |
| -6 | 0.5012V | -59 | 1.122mV |
| -7 | 0.4467V | -60 | 1.000mV |
| -8 | 0.3981V | -61 | 0.8913mV |
| -9 | 0.3548V | -65 | 0.5623mV |
| -10 | 0.3162V | -66 | 0.5012mV |
| -11 | 0.2818V | -67 | 0.4467mV |

4-15. SPURIOUS SIGNALS TEST (10 MHz to 22 GHz)**Specification***Table 4-15. Spurious Signals Test (10 MHz to 22 GHz) Specifications*

| SPURIOUS SIGNALS (Expressed in dB relative to the carrier level (dBc) at ALC level of 0 dBm) | Bands and Approximate Frequency Ranges (GHz) (See Frequency Ranges and Bandswitch Points for complete description) | | | | |
|--|--|------------------------------|-------------------------------|--------------------------------|-------------------------------|
| | Band 0 0.01 to <2.3 | Band 1 2.3 to <7.0 | Band 2 7.0 to <13.5 | Band 3 13.5 to <20.0 | Band 4 20.0 to 26.5 |
| Harmonics (up to 26.5 GHz) | < -35 | < -35 | < -35 | < -35 | < -35 |
| Subharmonics and multiples thereof (up to 26.5 GHz) | — | — | < -25 | < -25 | < -20 |
| Non-harmonically related spurious (CW and Manual Sweep mode only) | < -50 | < -70 | < -64 | < -60 | < -58 |
| Power line related and spurious due to fan rotation within 5 Hz below line frequency, and multiples thereof (CW mode only, all power levels) | | | | | |
| STANDARD INSTRUMENT | | | | | |
| Offset < 300 Hz from carrier | < -50 | < -50 | < -44 | < -40 | < -38 |
| Offset 300 Hz to 1 kHz from carrier | < -60 | < -60 | < -54 | < -50 | < -48 |
| Offset > 1 kHz from carrier | < -65 | < -65 | < -59 | < -55 | < -53 |

Description

The 8340A RF output signal is displayed on a spectrum analyzer to verify that the harmonic and non-harmonic spurious signals are at or below the specified level.

4-15. SPURIOUS SIGNALS TEST (10 MHz to 22 GHz) (Cont'd)

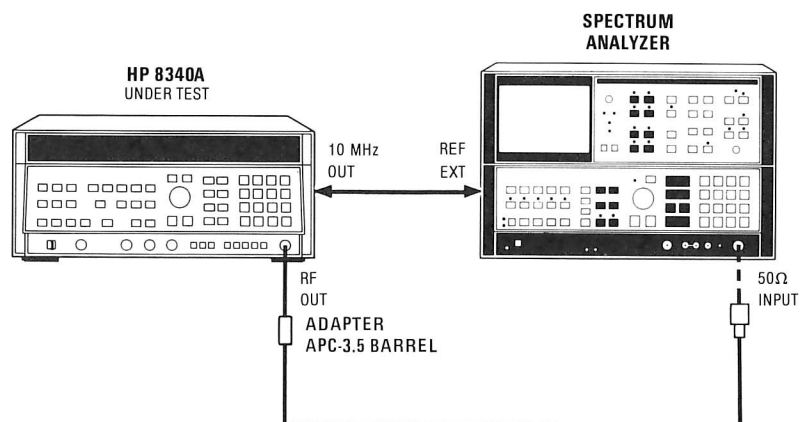

Figure 4-7. Spurious Signals Test Setup (10 MHz to 22 GHz)

Equipment

| | |
|------------------------|---|
| Spectrum Analyzer..... | HP 8566A |
| Adapter | HP P/N 5061-5311 (APC-3.5 female to female barrel) |
| Cable | HP P/N 08340-20124 (SMA male to SMA male) |

Procedure

1. Connect equipment as shown in Figure 4-7. The position of the 8340A under test can affect spurious responses; therefore, place the 8340A in its normal operating position (i.e., flat on its feet) for this test. Allow at least 30 minute warm up time.
2. Press the 8340A [**INSTR PRESET**]. Press the [**STOP FREQ**] key and enter [**2**] [**.**] [**3**] [**GHz**].
3. Press the 8340A [**POWER LEVEL**] key and enter [**0**] [**dBm**].
4. Press the [**CW**] key and enter any frequency of interest within the selected frequency range.
5. Set up the spectrum analyzer to view the 8340A RF output signal. Set the reference level to place the peak of the 8340A RF output signal on the reference level at the top graticule line.

4-15. SPURIOUS SIGNALS TEST (10 MHz to 22 GHz) (Cont'd)**NOTE**

When using a spectrum analyzer other than the HP 8566A, the spectrum analyzer may originate some mixing products that could appear on the display. If a signal is in question, increase the spectrum analyzer input attenuation by 10 dB, note if signal decreases in amplitude by 10 dB, then return the attenuator to its original position. If the signal in question comes from an external source, it will change by exactly 10 dB. If the signal in question originates in the spectrum analyzer, the level will either change by greater or less than 10 dB or may not change at all.

The 8340A rotary knob circuit may generate some noise spikes when the knob is rotated. These signals should disappear when rotation is stopped.

If a spurious signal is found and it appears out of specification, check the fundamental signal amplitude to ensure it is at 0 dBm. Then check spurious level by substituting a known amplitude signal on the spectrum analyzer.

6. Tune the spectrum analyzer across its full frequency range. Look for any spurious signals. For each spurious response determine what mechanism generated the spurious response and what specification applies.
 - a. Is the spurious response in question an integer multiple of the 8340A RF output signal? If it is, the "harmonic" specification applies.
 - b. Press the 8340A **[SHIFT]** key and then **[M2]** to display, from left to right, the YO harmonic number and the YO frequency. Is the spurious response in question an integer multiple of the YO frequency (and not a harmonic of the RF signal)? If it is the "subharmonic and multiples thereof" specification applies.

NOTE

Press the [CW] key to view the CW frequency in the ENTRY DISPLAY.

- c. If the spurious response in question does not meet one of the above criteria, the "non-harmonically related" specification applies.
7. Repeat steps 4 through 7 at any frequency of interest within this frequency band.
8. Press the 8340A **[STOP FREQ]** key and enter the stop frequency for the next frequency band. Press the **[START FREQ]** key and enter the start frequency for the next frequency band. Repeat steps 3 through 8 until all 8340A frequency bands have been tested up to 22 GHz.

4-16. SPURIOUS SIGNALS TEST (22 to 26.5 GHz)

NOTE

Non-harmonically-related spurious responses, resulting from mixing products produced by two or more signals within the 8340A, follow a mathematical relationship to the signals that generated them. If the level of all such signals up to 22 GHz are within the specification, then no mixing products will be out of specification above 22 GHz. Therefore, no test is provided for non-harmonically-related spurious signals above 22 GHz.

Specification

Table 4-16. Spurious Signals Test (20 to 26.5 GHz) Specifications

| SPURIOUS SIGNALS (Expressed in dB relative to the carrier level (dBc) at ALC level of 0 dBm) | Bands and Approximate Frequency Ranges (See Frequency Ranges and Bandswitch Points for complete description.) |
|--|---|
| | Band 4 20 to 26.5 GHz |
| Harmonics (up to 26.5 GHz) | < -35 |
| Subharmonics and multiples thereof (up to 26.5 GHz) | < -20 |
| Non-harmonically related spurious (CW and Manual Sweep mode only) | < -58 |
| Power line related and spurious due to fan rotation within 5 Hz below line frequency, and multiples (CW mode only, all power levels) STANDARD INSTRUMENT Offset < 300 Hz from carrier Offset 300 Hz to 1 kHz from carrier Offset > 1 kHz from carrier | < -38 < -48 < -53 |

4-16. SPURIOUS SIGNALS TEST (22 to 26.5 GHz) (Cont'd)

Description

The 8340A Under Test RF output signal is fed through a 20 dB pad and a high pass filter and is then down converted using a mixer and an 8340A as a Local Oscillator. the mixer output is fed to a low frequency spectrum analyzer.

The 8340A Under Test is set to a CW frequency. All possible harmonics of the RF signal and harmonics of the YO frequency that could fall within the 22 GHz to 26.5 GHz range are determined.

The Local Oscillator 8340A is set to a CW frequency 50 MHz below each harmonic. The specification is in dB below the carrier. To establish the carrier level at the IF, the 8340A Under Test is temporarily set to the frequency of the harmonic and a reference level is established on the Spectrum Analyzer. The 8340A Under Test is returned to the original CW frequency. The amplitude of the harmonic displayed on the Spectrum Analyzer is used to determine that the harmonic is at or below the specified level.

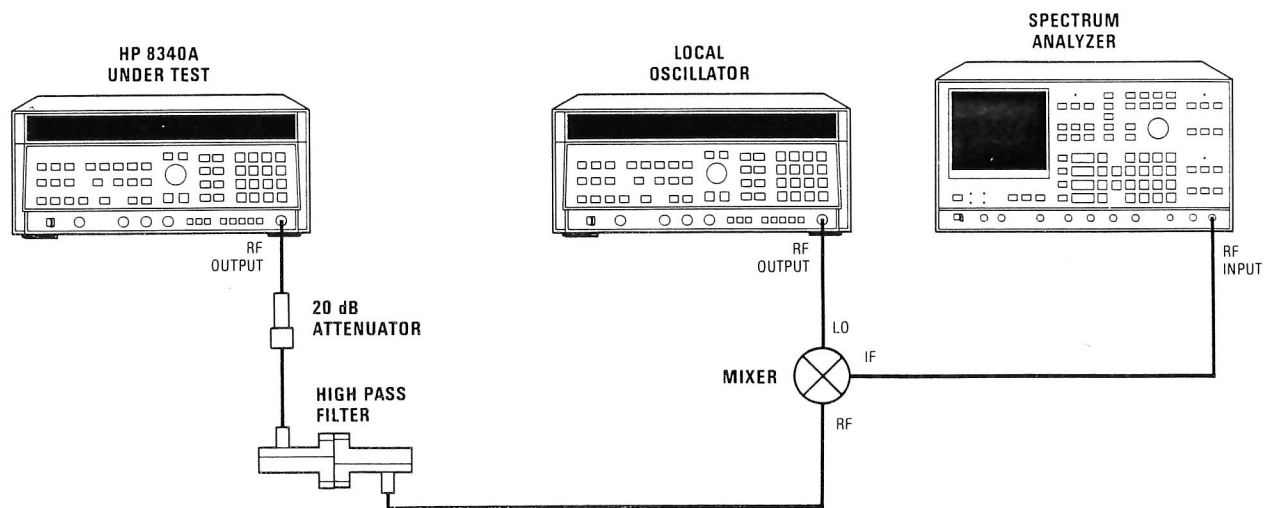

Figure 4-8. Spurious Signals Test Setup (22 to 26.5 GHz)

Equipment

| | |
|-------------------------------------|--------------------|
| Local Oscillator | HP 8340A Opt. 001 |
| 20 dB Attenuator | HP 8493C Opt 020 |
| High Pass Filter (2 required) | HP K281C |
| Mixer | RHG DMS 1-26 |
| Spectrum Analyzer | HP 3585A |
| Adapter | HP P/N 5061-5311 |
| (APC-3.5 female to female barrel) | |
| Cable | HP P/N 08340-20124 |
| (SMA male to SMA male) | |

4-16. SPURIOUS SIGNALS TEST (22 to 26.5 GHz) (Cont'd)**Procedure**

1. Connect equipment as shown in Figure 4-8. Allow at least a 30 minute warmup time. Press the Local Oscillator 8340A **[INSTR PRESET]** and **[PEAK]** on.
2. Press the 8340A Under Test **[INSTR PRESET]**. Press **[POWER LEVEL]**. If the power level in the ENTRY DISPLAY is not 0 dBm, enter **[0] [dBm]**. Press the **[CW]** key and enter any CW frequency in the 10 MHz to 26.5 GHz range.
3. Determine all possible harmonic frequencies of the RF signal that could fall within the 22 to 26.5 GHz range. Press **[SHIFT] [M2]** to display from left to right; the band number (in POWER dBm display) and the YO frequency. Determine all possible YO harmonic frequencies that could fall within the 22 to 26.5 GHz range.
4. Press the Local Oscillator 8340A **[CW]** key and enter a frequency 50 MHz below the harmonic frequency to be tested. Press the **[POWER LEVEL]** key and, using the rotary knob, increase the power level until the UNLEVELED indicator light comes **ON**. Slowly decrease the power level until the UNLEVELED light just goes **OFF**.
5. Press the 8340A Under Test **[SAVE]** key enter **[1]** to save the current instrument state. Press **[CW]** and enter the harmonic frequency to be tested. Set the Spectrum Analyzer to view the 50 MHz IF signal with the peak of the signal at the top graticule line.
6. Press the 8340A Under Test **[RECALL]** key and enter **[1]** to recall the original instrument state. The amplitude of the harmonic displayed on the Spectrum Analyzer should be at or below the specified test.
7. Repeat steps 4 through 6 for each harmonic frequency determined in step 3.
8. Set the 8340A Under Test to another CW frequency and repeat steps 3 through 7.

4-17. SINGLE SIDEBAND PHASE NOISE

Specification

Table 4-17. Omitted

Description

This test is performed in three steps: SYSTEM CALIBRATION, PHASE NOISE MEASUREMENT, and PHASE NOISE CALCULATION. A second 8340A is used as a local oscillator (LO) to mix down the microwave frequency from the 8340A under test (DUT) to a 1 MHz IF. The IF signal is amplified and, for 30 Hz, 100 Hz and 1 kHz offsets, sent directly to a low frequency spectrum analyzer (HP 3585A). For 10 kHz and 100 kHz offsets, a 1 MHz notch filter is inserted between the amplifier and the 3585A to attenuate IF signal and obtain increased dynamic range on the 3585A. Phase noise is measured using the OFFSET and NOISE LVL functions of the 3585A.

SYSTEM CALIBRATION obtains the system's frequency response data (Cal Data (CD) and IF Cal Data (IFCD), measured in dBc). A zero dBm, 1 MHz IF is established and then the LO frequency is reduced to obtain 1.00003, 1.0001, and 1.001 MHz IFs. At each point, the power level at the peak of the IF is recorded as the Cal Data (CD). A 1 MHz notch filter is then inserted between the amplifier and the 3585A. The LO frequency is again reduced to obtain 1.01 and 1.1 MHz IFs, and the Cal Data for these points is recorded. The LO frequency is then increased to obtain a 1 MHz IF and the response due to the 1 MHz notch filter is recorded as the IF Cal Data (IFCD). This data is required for calculating the actual phase noise for the 10 kHz and 100 kHz offsets. Since it is not required for the 30 Hz, 100 Hz and 1 kHz offsets, IFCD is defined as zero at these points.

PHASE NOISE MEASUREMENT obtains phase noise data for DUT frequencies of 2.202, 6.902, 13.402, 19.502, and 26.032 GHz. These specific frequencies typically have the worst case phase noise for the 8340A. The DUT is adjusted for the test frequency and then the LO

4-17. SINGLE SIDEBAND PHASE NOISE (Cont'd)

frequency is adjusted to obtain a 1 MHz ±0.9 Hz IF. A signal to noise level (IF to phase noise level at 30 Hz, 100 Hz 1 kHz, 10 kHz, and 100 kHz offsets from IF) measurement is performed using the OFFSET and NOISE LVL functions of the 3585A and the results are recorded as the Measured Noise Level (MNL, measured in dBc).

PHASE NOISE CALCULATION takes the data obtained for MNL and adds and subtracts the calibration data and a 3 dB correction factor to obtain the actual phase noise. The formula that is used is:

$$\text{Actual Phase Noise} = \text{MNL} + \text{IFCD} - \text{CD} - 3 \text{ dB}$$

IFCD is the response of the 1 MHz notch filter at 1 MHz. Since the filter is not installed during the 10 Hz, 100 Hz and 1 kHz offset measurements, IFCD = 0. During the 10 kHz and 100 kHz offset measurements, the notch filter attenuates the IF causing the power difference between the IF and the phase noise to be smaller than it actually is, therefore IFCD must be added to MNL to correct for this. The system's frequency response (CD) causes the difference between the IF level and the phase noise level to be greater than it actually is, therefore CD must be subtracted from MNL. A factor of 3 dB is subtracted from MNL to correct for the LO's phase noise contribution.

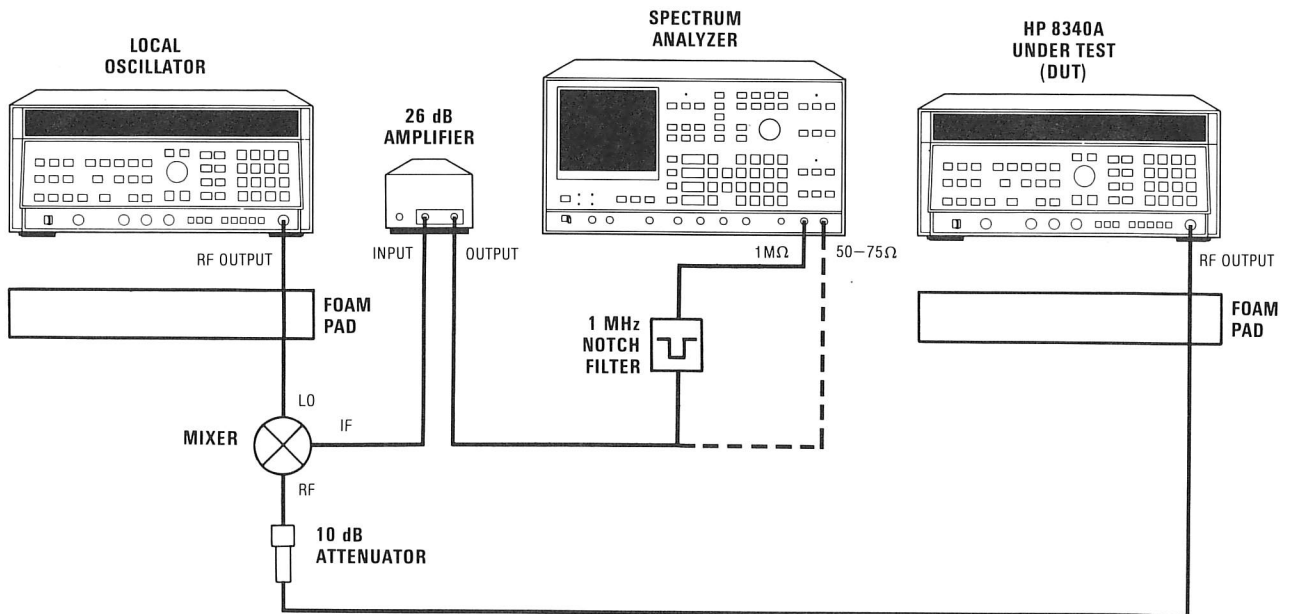

Figure 4-9. Single Sideband Phase Noise Test Setup

4-17. SINGLE SIDEBAND PHASE NOISE (Cont'd)**Equipment**

| | |
|----------------------------------|---|
| Synthesized Sweeper | HP 8340A Opt. 001 |
| Spectrum Analyzer | HP 3585A |
| Power Amplifier | HP 8447F |
| Attenuator | HP 8493C Opt. 010 |
| Mixer | RHG DMS 1-26 |
| Adapters | |
| APC 3.5 (f) to APC 3.5 (f) | HP P/N 1250-1749 |
| SMA (m) to BNC (f) | HP P/N 1250-1200 |
| Foam Pads | (Refer to note following step 1) |
| 1 MHz Notch Filter | (See schematic in Recommended Test Equipment list, Section I) |

Procedure

1. Connect equipment as shown in Figure 4-9 with the amplifier connected directly to the 3585A 50 Ohm input.

NOTE

The foam pads shown in Figure 4-9 are required to isolate the DUT and LO from mechanical vibrations which could induce phase noise.

NOTE

In this procedure, the LO is programmed for +10 dBm. At some points the LO may indicate an unlevelled condition. This is to be expected and does not affect the phase noise measurement.

2. On the LO, press [INSTR PRESET] [CW] [2] [.] [2] [0] [1] [GHz] [POWER LEVEL] [1] [0] [dB(m)] [PEAK].
3. On the DUT, press [INSTR PRESET] [CW] [2] [.] [2] [0] [2] [GHz] [POWER LEVEL] [0] [dB(m)] [PEAK].
4. On the 3585A, press INSTR PRESET, CENTER FREQUENCY, 1 MHz, FREQUENCY SPAN, 1 MHz.
5. Switch the 3585A AUTO RANGE and REF LVL TRACK off.
6. Allow the equipment to warm up for 1 hour.
7. Adjust the 3585A marker to the peak of the IF.
8. On the 3585A, press COUNTER.
9. Adjust the frequency of the LO for a 3585A COUNTER reading of 1 MHz \pm 0.9 Hz. This removes any frequency offsets between the DUT and LO.
10. Adjust the output power of the DUT for 0 dBm at the peak of the IF. Select a REFERENCE LEVEL of 0 dBm on the 3585A.

4-17. SINGLE SIDEBAND PHASE NOISE (Cont'd)

SYSTEM CALIBRATION

30 Hz Offset Calibration

11. On the 3585A, press FREQUENCY SPAN, 250 Hz, RES BW, 3 Hz. Allow one sweep to occur. Ensure power at peak of IF is still 0 dBm.
12. Reduce LO frequency by 30 Hz (IF = 1.00003 MHz ±0.9 Hz).
13. Allow one sweep of the 3585A to occur. Adjust the 3585A marker to the peak of the IF. Record the marker power level (Cal Data) into Table 4-18.

Table 4-18. Phase Noise Calibration Data

| Step | Offset (Hz) | Cal Data (dB) |
|------|-------------|---------------|
| 13 | 30 | CD = |
| 14 | 100 | CD = |
| 16 | 1K | CD = |
| 19 | 10K | CD = |
| 21 | 100K | CD = |
| 22 | 0 | IFDC = |

100 Hz Offset Calibration

14. Reduce the LO frequency by 70 Hz (IF = 1.0001 MHz ±0.9 Hz). Repeat step 13.

1 kHz Offset Calibration

15. On the 3585A, press FREQUENCY SPAN, 2500 Hz, RES BW, 30 Hz.
16. Reduce LO frequency by 900 Hz (IF = 1.001 MHz ±0.9 Hz). Repeat step 13.

10 kHz Offset Calibration

17. Connect 1 MHz Notch Filter as shown in Figure 4-9. Select 1 MOhm input impedance on the 3585A.
18. On the 3585A, press FREQUENCY SPAN, 25 kHz, RES BW, 100 Hz.
19. Reduce LO frequency by 9 kHz (IF = 1.01 MHz ±0.9 Hz). Repeat step 13.

100 kHz Offset Calibration

20. On the 3585A, press FREQUENCY SPAN, 250 kHz, RES BW, 1 kHz.
21. Reduce LO frequency by 90 kHz (IF = 1.1 MHz ±0.9 Hz). Repeat step 13.

IF Cal Data

22. Increase the LO frequency by 100 kHz (IF = 1 MHz ±0.9 Hz). Repeat step 13.

4-17. SINGLE SIDEBAND PHASE NOISE (Cont'd)

PHASE NOISE MEASUREMENT

23. Connect equipment as shown in Figure 4-9 with the amplifier connected directly to the 3585A 50 Ohm input. Return 3585A to 50 Ohm input impedance.
24. On the DUT, press **[POWER LEVEL] [0] [dB(m)]**. Select a 3585A REFERENCE LEVEL to place the peak of the IF at the top graticule of the display. Ensure IF = 1 MHz \pm 0.9 Hz. If necessary, adjust LO for a 3585A COUNTER reading of 1 MHz \pm 0.9 Hz.
25. On the 3585A, press FREQUENCY SPAN, 250 Hz, RES BW, 3 Hz. Step the RANGE until the overload light just turns on and then increment it one step. Allow one sweep to occur.

30 Hz Offset

26. On the 3585A, press MANUAL, CLEAR A, MKR→CF, COUNTER.
27. On the 3585A, press OFFSET, ENTER OFFSET, CF STEP SIZE, 30 Hz, MANUAL, STEP UP (key), NOISE LVL. The noise level measurement takes approximately 30 seconds. For an accurate reading, allow at least 2 measurements to be made before recording value. Record Measured Noise Level (MNL) into Table 4-19.

Table 4-19. Phase Noise Measurement Data

| Step | Offset (Hz) | Measured Noise Level (MNL, dBc (1 Hz)) | | | | |
|------|-------------|--|-----------|------------|------------|------------|
| | | 2.202 GHz | 6.902 GHz | 13.402 GHz | 19.502 GHz | 26.032 GHz |
| 27 | 30 | | | | | |
| 29 | 100 | | | | | |
| 31 | 1K | | | | | |
| 34 | 10K | | | | | |
| 36 | 100K | | | | | |

28. On the 3585A, press COUNTER, NOISE LVL, OFFSET, CONT. Return marker to peak of IF and ensure COUNTER reading is 1 MHz \pm 0.9 Hz. If necessary, adjust LO for a 1 MHz IF. If the IF drifted more than 6 Hz, steps 26 through 28 must be repeated.

100 Hz Offset

29. Repeat steps 26 through 28 with a CF STEP SIZE of 100 Hz substituted in step 27.

1 kHz Offset

30. On the 3585A, press FREQUENCY SPAN, 2.5 kHz, RES BW, 30 Hz.
31. Repeat steps 26 through 28 with a CF STEP SIZE of 1 kHz substituted in step 27.

4-17. SINGLE SIDEBAND PHASE NOISE (Cont'd)

10 kHz Offset

- 32. Connect the equipment in Figure 4-9 with the 1 MHz Notch Filter connected. Select the 1 MOhm input impedance on the 3585A.
- 33. On the 3585A, press FREQUENCY SPAN, 25 kHz, RES BW, 100 Hz. Decrement the RANGE until the overload light just turns on and then increment it one step.
- 34. Repeat steps 26 through 28 with a CF STEP SIZE of 10 kHz substituted in step 27.

100 kHz Offset

- 35. On the 3585A, press FREQUENCY SPAN, 250 kHz, RES BW, 1 kHz.
- 36. Repeat steps 26 through 28 with a CF STEP SIZE of 100 kHz substituted in step 27.
- 37. Repeat steps 23 through 36 for the CW frequencies shown in Table 4-20.

Table 4-20. Phase Noise Test Frequencies

| CW Frequency (GHz) | |
|--------------------|--------|
| DUT | LO |
| 6.902 | 6.901 |
| 13.402 | 13.401 |
| 19.502 | 19.501 |
| 26.032 | 26.031 |

PHASE NOISE CALCULATION

- 38. Using the data obtained in Table 4-18 and Table 4-19, calculate and enter the Actual Phase Noise into Table 4-20.

For example: Assume the following data was obtained for the 30 Hz offset at 26.032 GHz

CD = 0 dB (obtained in step 13)

MNL = -50.8 dB (obtained in step 27)

IFCD is defined to be 0 for a 30 Hz offset (also for 100 Hz and 1 kHz)

Therefore

$$\begin{aligned}
 \text{Actual Phase Noise} &= \text{MNL} + \text{IFCD} - \text{CD} - 3 \text{ dB} \\
 &= -50.8 + 0 - 0 - 3 \\
 &= -53.8
 \end{aligned}$$

The value -53.8 would be entered into Table 4-21.

4-17. SINGLE SIDEBAND PHASE NOISE (Cont'd)

For example: Assume the following data was obtained for the 10 kHz offset at 2.202 GHz

CD = -25.6 dB (obtained in step 19)

IFCD = -44.2 dB (obtained in step 22)

MNL = -66.0 dB (obtained in step 34)

Therefore

$$\begin{aligned} \text{Actual Phase Noise} &= \text{MNL} + \text{IFCD} - \text{CD} - 3 \text{ dB} \\ &= -66.0 + (-44.2) - (-25.6) - 3 \\ &= -87.6 \end{aligned}$$

The value -87.6 would be entered into Table 4-21.

Table 4-21. Phase Noise Test Results

| Actual Single Sideband Phase Noise (dBc/1 Hz) | | | | | |
|--|-----------|-----------|------------|------------|------------|
| Offset (Hz) | 2.202 GHz | 6.902 GHz | 13.402 GHz | 19.502 GHz | 26.032 GHz |
| 30 | | | | | |
| 100 | | | | | |
| 1K | | | | | |
| 10K | | | | | |
| 100K | | | | | |
| 1. Actual = IFCD ² - CD - MNL + 3dB 2. IFCD = 0 for 30 Hz, 100 Hz, and 1 kHz offsets = value measured in step 22 (see Table 4-18) for 10K and 100 kHz offsets | | | | | |

4-18. POWER SWEEP TEST

Specification

Table 4-22. Power Sweep Test Specifications

Power Sweep

Range

Displayed: 0 to 40 dB/sweep

Actual: At least 10 dB at any given frequency (at least 20 dB in DECOUPLED mode; see Figure a below.)

Accuracy

Starting Power Level: Same as Output Power Accuracy

Power Sweep Width and Linearity: See Figure 2 in Table 1-1.

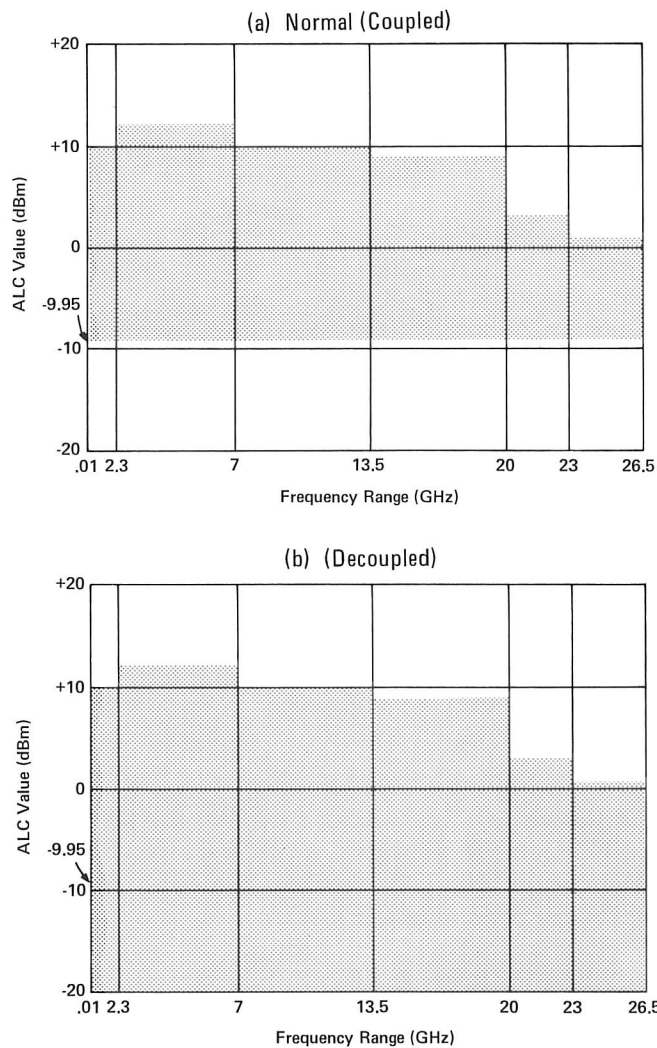

Figure A. Power Sweep Range

In normal operation (a), the ALC does not operate below -9.95 dBm (see Figure 2 in Table 1-1), and so the maximum power sweep range is the difference of -9.95 dBm and the maximum leveled power available at the frequency of interest (specified leveled power shown in diagram). In the DECOUPLED mode (b), the power sweep range is extended because the ALC can operate down to -20 dBm.

4-18. POWER SWEEP TEST (Cont'd)

Description

The 8340A under test is set to allow the ALC and the step attenuator to be operated independently ([SHIFT] [PWR SWP]). The 8340A is then set to do a 20 dB power sweep from -20 dBm to 0 dBm at a CW frequency. The 8340A is set to do a manual sweep. The 8340A output power is measured at the two end points, -20 dBm and 0 dBm, using a power meter.

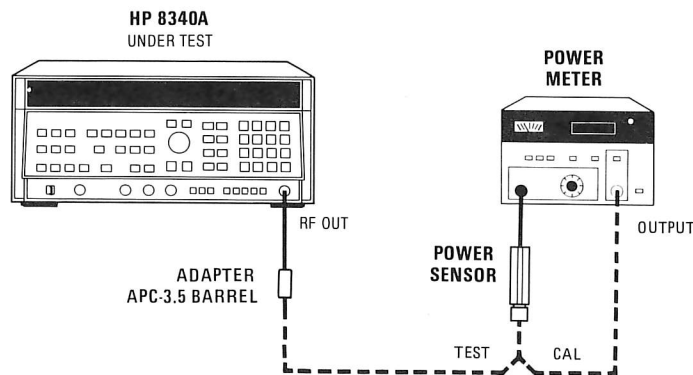

Figure 4-10. Power Sweep Test Setup

Equipment

| | |
|-------------------|---|
| Power Meter..... | HP 436A |
| Power Sensor..... | HP 8485A |
| Adapter | HP P/N 5061-5311 (APC 3.5 female to female barrel) |

Procedure

1. Connect equipment as shown in Figure 4-10. Connect the 8485A Power Sensor to the Power Meter. Allow at least 30 minutes warm up time. Set the Power Meter's calibration factor switch to include 1 GHz, then zero and calibrate the Power Meter before connecting the Power Sensor to the 8340A.
2. Press 8340A [INSTR PRESET]. Press the [CW] key and enter [1] [GHz].
3. Press [SHIFT] [PWR SWP] to set the 8340A to allow the ALC and RF step attenuator to be independently controlled.

NOTE

The step up and step down keys control the RF attenuator. The numeric key pad and rotary knob control the ALC power level.

4-18. POWER SWEEP TEST (Cont'd)

4. Enter **[−] [2] [0] [dBm]** ALC Power level to set the start of the power sweep at −20 dBm. Press **[PWR SWP]** and enter **[2] [1] [dBm]** to set the power sweep range to >20 dB (The maximum power sweep range is from −20 dBm to maximum power).
5. Press the **[MANUAL]** key. Turn the rotary knob counterclockwise to find the beginning of the power sweep (i.e., the power meter indication is at maximum and no longer changing). Record the power meter indication.

NOTE

The POWER dBm display will indicate the approximate output power during a very slow or manual sweep.

6. Rotate the rotary knob clockwise to find the end of the power sweep (i.e., the power meter indication is at maximum and no longer changing). Record the power meter indication.
7. The difference between the power meter indications recorded in step 5 and step 6 must be ≥ 20 dB.
8. Press the **[CW]** key and enter **[5] [GHz]**. Set the power meter's calibration factor switch to include this frequency. Repeat steps 5 through 7 at CW frequencies of 10, 15, and 26 GHz.

4-19. PULSE MODULATION ON / OFF RATIO TEST

NOTE

THIS TEST IS NOT APPLICABLE TO INSTRUMENTS EQUIPPED WITH OPTION 006, DELETE PULSE MODULATION

Specification

Table 4-23. Pulse Modulation ON/OFF Ratio Test Specifications

| |
|--|
| <p>For CW mode and RF frequencies ≥ 400 MHz only:</p> <p>On/Off Ratio: > 80 dB</p> |
|--|

Description

The 8340A under test is set to a CW frequency at 0 dBm. The RF output level is viewed on a spectrum analyzer. A reference level is set on the spectrum analyzer display, the 8340A PULSE key is pressed (ON).

NOTE

The 50 ohm termination on the 8340A PULSE input simulates the RF OFF state when PULSE is selected (ON).

The difference between the two spectrum analyzer displayed levels is the pulse ON/OFF ratio.

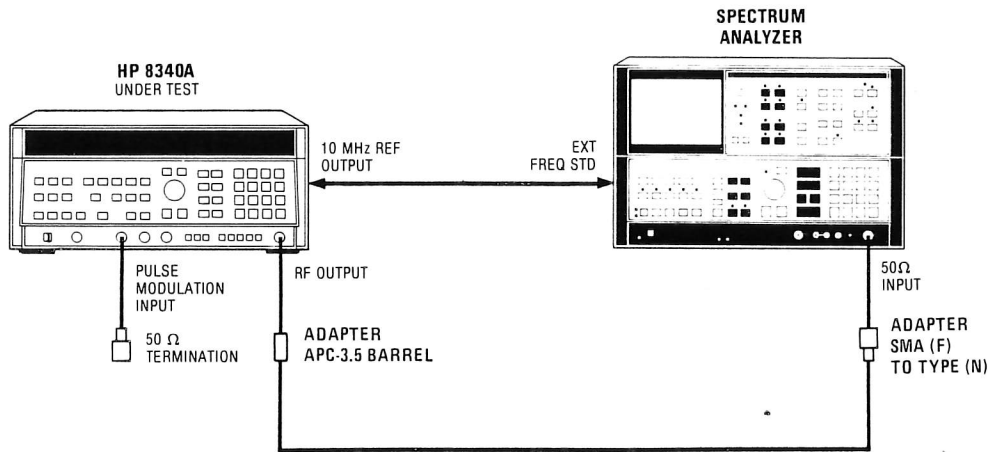

Figure 4-11. Pulse Modulation ON/OFF Ratio Test Setup

Equipment

| | |
|--------------------------------|--------------------|
| Spectrum Analyzer | HP 8566A |
| 50 Ohm Termination | HP 10100C |
| Cable SMA (m) to SMA (m) | HP P/N 08340-20124 |

4-19. PULSE MODULATION ON / OFF RATIO TEST (Cont'd)**Procedure**

1. Connect equipment as shown in Figure 4-11. Allow at least 30 minutes warm up time.
2. Press 8340A [**INSTR PRESET**] then [**CW**] and enter [**1**] [**GHz**]. RF power level should be 0 dBm.
3. Set the spectrum analyzer CENTER FREQUENCY to equal the 8340A CW frequency, FREQUENCY SPAN 200 Hz, RES BW 30 Hz, PEAK SEARCH, MKR → CF, MKR → REF LVL, MKRΔ.
4. Press 8340A [**PULSE**] key (ON). The spectrum analyzer marker delta amplitude level should be greater than 80 dB.
5. Repeat steps 2 through 4 at CW frequencies of 3, 9, 15, and 22 GHz.

NOTE

For further verification of the ON/OFF Ratio, steps 2 through 4 may be repeated for other frequencies of interest.

4-20. PULSE MODULATION RISE AND FALL TIME TEST

NOTE

THIS TEST IS NOT APPLICABLE TO INSTRUMENTS EQUIPPED WITH OPTION 006, DELETE PULSE MODULATION.

Specification

Table 4-24. Pulse Modulation Rise and Fall Time Test Specification

| |
|---|
| For CW mode and frequencies ≥ 400 MHz only: |
| Rise (T_R) and Fall (T_F) Times: < 25 nanoseconds |

Description

The 8340A under test RF output frequency is down converted to 50 MHz using a mixer and a second 8340A as a local oscillator. The 50 MHz IF signal is amplified and applied to an oscilloscope. The 8340A under test is pulsed using a pulse generator. The pulse generator output is also applied to the oscilloscope. The oscilloscope is used to measure the pulse envelope rise and fall times. Refer to Figure 4-12 Pulse Definitions.

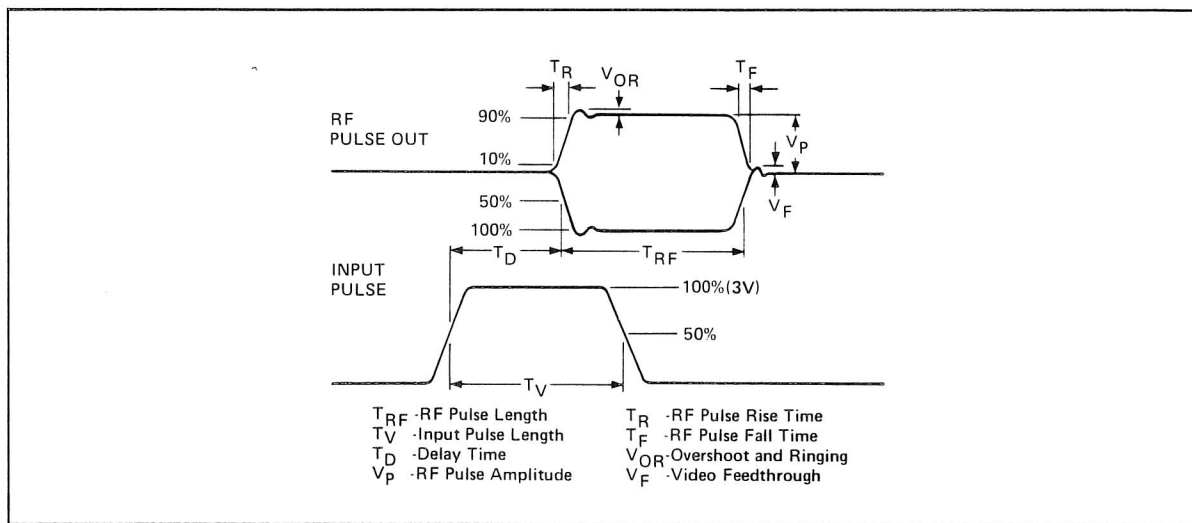

Figure 4-12. Pulse Definitions

Equipment

| | |
|-----------------------------|-------------------|
| Local Oscillator | HP 8340A Opt. 001 |
| Pulse Generator | HP 8012B |
| Amplifier | HP 8447F |
| Oscilloscope | HP 1741A |
| Adapter | HP P/N 5061-5311 |
| 10 dB Attenuator | HP 8493C Opt. 010 |
| Mixer | RHG DMS 1-26 |
| Low Pass Filter (LPF) | 9135-0260 |

Procedure

1. Connect equipment as shown in Figure 4-13. Connect the mixer directly to the local oscillator RF output to obtain maximum LO drive to the mixer. Connect the BNC tee directly to the 8340A PULSE IN connector. Allow at least 30 minutes warm up time.

4-20. PULSE MODULATION RISE AND FALL TIME TEST (Cont'd)

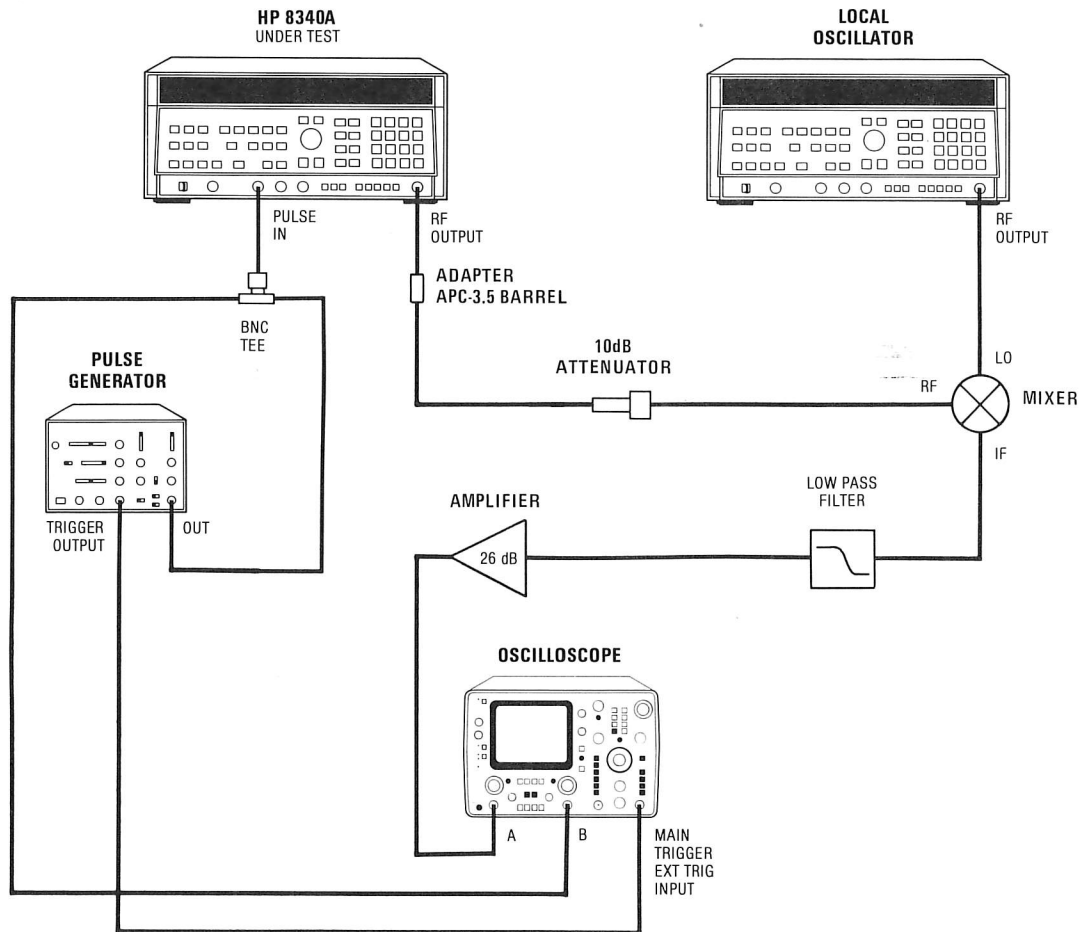

Figure 4-13. Pulse Modulation Rise and Fall Time Test Setup

- Set up the 8012B Pulse Generator as follows:

| | |
|------------------------------------|--------------------|
| OFFSET | OFF |
| POLARITY | + |
| OUTPUT | NORMAL |
| INT LOAD | IN |
| PULSE PERIOD slide switch | 1 μ -.1m |
| TRANSITION TIME slide switch | minimum (5n) |
| AMPLITUDE slide switch | top position (5.0) |
| PULSE DOUBLE/NORMAL | NORMAL |
| PULSE DELAY slide switch | minimum |
| Pulse Delay VERNIER | fully CCW |
| LEADING EDGE control | fully CCW |
| PULSE WIDTH slide switch | 10n-1 μ |
| TRAILING EDGE control | fully CCW |

- Set both oscilloscope channels A and B for 50 ohm input. Set the oscilloscope to view the pulse generator output waveform. Adjust the 8012B pulse width VERNIER for a 100 nanosecond pulse. Adjust the pulse period VERNIER for a 10 microsecond period.

4-20. PULSE MODULATION RISE AND FALL TIME TEST (Cont'd)

Adjust the amplitude VERNIER for about a 3V pulse amplitude (TTL level). Set the oscilloscope to trigger on this pulse (trigger on channel B)

4. Press **[INSTR PRESET]** on both the 8340A under test and the local oscillator 8340A. Press the 8340A under test **[CW]** key and enter **[1] [GHz]** and press the **[PULSE]** modulation key. Press the local oscillator 8340A **[CW]** key and enter **[.] [9] [5] [GHz]**. The IF frequency is then 50 MHz. Set the local oscillator 8340A for +10 dBm or maximum leveled output. The 8340A under test RF power should be 0 dBm.

NOTE

For best accuracy in this test, the Local Oscillator drive to the mixer should be $\geq +6$ dBm. The 8340A Option 001 used as the LO will typically produce +6 dBm at any frequency, although it is only guaranteed to produce +4 dBm above 23 GHz. If +6 dBm is not available at a test frequency, try a slightly different frequency and be sure to have PEAK on.

5. Set the oscilloscope horizontal for 50 nanoseconds/division and select channel A input only. Adjust the channel A (pulsed IF input signal) vertical gain and position so that the pulse OFF is at the 0% graticule line and the pulse ON is at 100% graticule line. Select the horizontal MAG X10. The oscilloscope is now calibrated for 5 nanoseconds/division. Adjust the horizontal position control to position the modulation envelope so that the 10% point of the envelope rise time is at the center vertical graticule line similar to Figure 4-14.

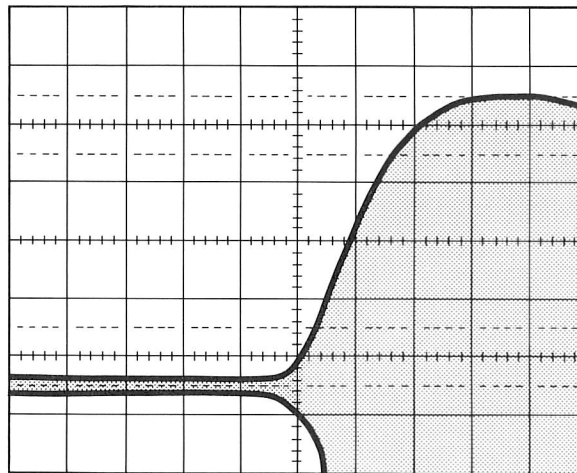

Figure 4-14. Pulse Modulation Rise Time Waveform.

6. The 90% point of the envelope rise time should be less than 25 nanoseconds (5 horizontal divisions) from the 10% point.

4-20. PULSE MODULATION RISE AND FALL TIME TEST (Cont'd)

7. Adjust the oscilloscope horizontal position control to view the modulation envelope fall time. Position the waveform so that the modulation envelope crosses the 90% graticule at a vertical graticule line similar to Figure 4-15.

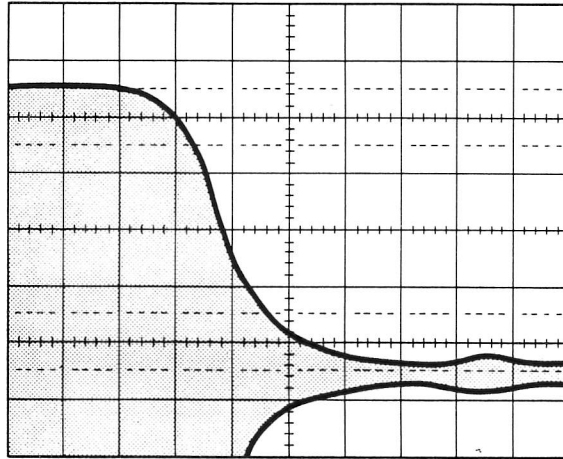

Figure 4-15. Pulse Modulation Fall Time Waveform

8. The 10% point should be <25 nanoseconds (5 divisions) from the 90% point.
9. Repeat steps 5 through 8 at CW frequencies of 3, 9, 15, and 22 GHz. Set the local oscillator 8340A CW frequency to be 50 MHz below the 8340A under test frequency.

4-21. PULSE MODULATION ACCURACY TEST

NOTE

THIS TEST IS NOT APPLICABLE TO INSTRUMENTS EQUIPPED WITH OPTION 006, DELETE PULSE MODULATION.

Specification

Table 4-25. Pulse Modulation Accuracy Test Specifications

| | | |
|--|-----------------------|----------------------------|
| For CW mode and frequencies ≥ 400 MHz only: Minimum Internally Leveled RF Pulse Width (TI, RFI): 100 nanoseconds Pulse Repetition Frequency: Internally leveled: 100 Hz to 5 MHz Accuracy of Internally Leveled RF Pulse VI, PI (relative to CW mode level): <p style="text-align: center;">NOTE</p> <p style="text-align: center;">ALC attempts to hold pulse amplitude to same level as leveled CW signal.</p> | | |
| Bands and Approximate Frequency Ranges (GHz) (See Frequency Ranges and Bandswitch Points for complete description) | | |
| Pulse Width | Band 0 0.4 to <2.3 | Bands 1 - 4 2.3 to 26.5 |
| 100 to <200 ns | +3/-0.3 dB* | P441.5/-0.3 dB* |
| 200 to <500 ns | +1.5/-0.3 dB* | ± 0.3 dB |
| ≥ 500 ns | ± 0.3 dB | ± 0.3 dB |
| * +15 to +55°C. Duty Cycle must be >0.01% | | |

Description

The 8340A under test RF output frequency is down converted to 50 MHz using a mixer and a second 8340A as a local oscillator. The 50 MHz IF signal is amplified and applied to an oscilloscope. The 8340A under test is pulsed using a pulse generator. The IF modulation envelope is positioned to convenient horizontal graticule lines. The pulse is turned OFF and the 8340A output power level is adjusted so that the IF carrier is at the horizontal graticule lines established when the 8340A was being pulsed. The change in 8340A output power level is the accuracy error of the leveled RF pulse.

Equipment

- Local Oscillator HP 8340A Opt. 001
- Pulse Generator HP 8012B
- Amplifier HP 8447F
- Oscilloscope HP 1741A
- Adapter HP Part No. 5061-5311
- 10 dB Attenuator HP 8493C Opt. 010
- Mixer RHG DMS 1-26
- Low Pass Filter (LPF) HP P/N 9135-0260

4-21. PULSE MODULATION ACCURACY TEST (Cont'd)

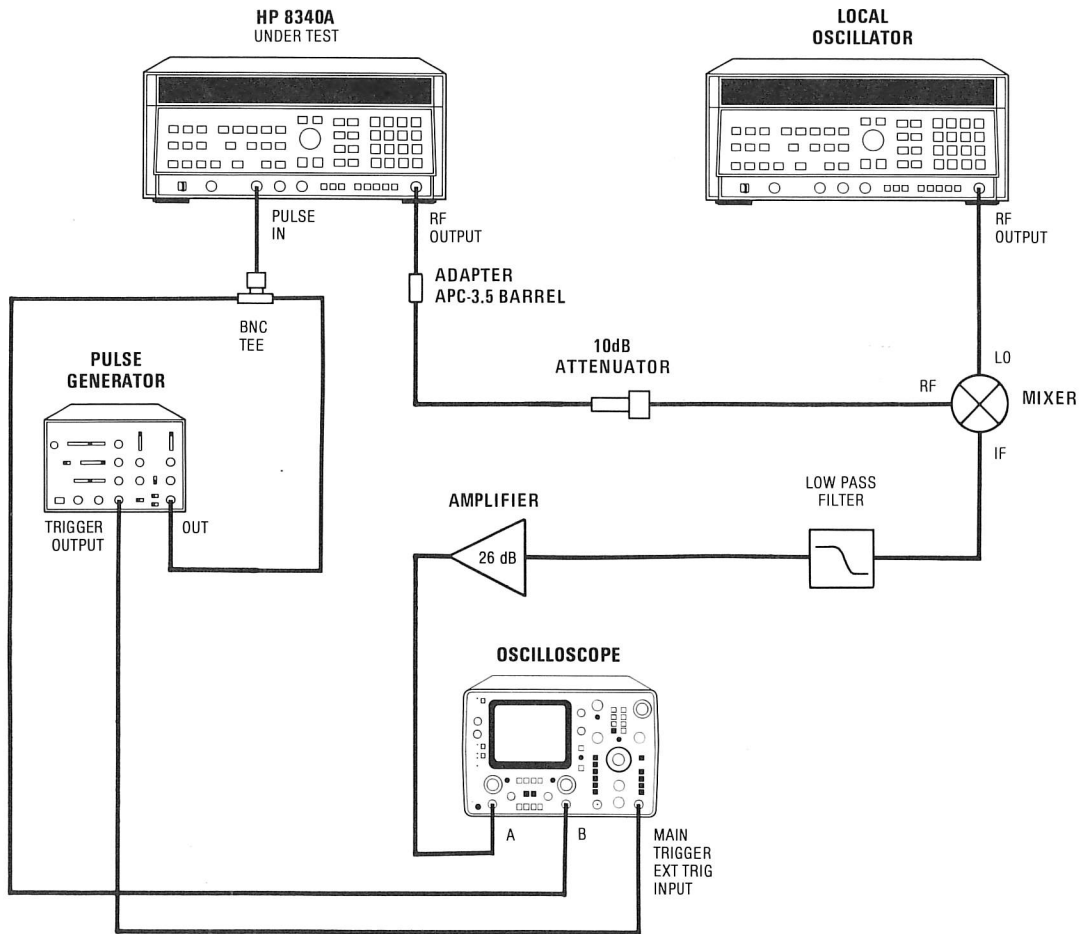

Figure 4-16. Pulse Modulation Accuracy Test Setup

Procedure

1. Connect equipment as shown in Figure 4-16. Connect the mixer directly to the LO 8340A RF output connector to obtain the maximum mixer LO input level. Connect the BNC tee directly to the 8340A PULSE IN connector. Allow at least 30 minutes warm up time.

4-21. PULSE MODULATION ACCURACY TEST (Cont'd)

2. Set up the 8012B Pulse Generator as follows:

| | |
|------------------------------------|--------------------|
| PULSE PERIOD slide switch | 1 μ –.1m |
| TRANSITION TIME slide switch | minimum (5n) |
| AMPLITUDE slide switch | top position (5.0) |
| PULSE DOUBLE/NORMAL | NORMAL |
| PULSE DELAY slide switch | minimum |
| Pulse Delay VERNIER | fully CCW |
| LEADING EDGE control | fully CCW |
| PULSE WIDTH slide switch | 10n–1 μ |
| TRAILING EDGE control | fully CCW |
| OFFSET | OFF |
| POLARITY | + |
| OUTPUT | NORMAL |
| INT LOAD | IN |

3. Set both oscilloscope channels (A and B) for 50 Ohm input. Set the oscilloscope to view the pulse generator output waveform. Adjust the 8012B pulse width VERNIER for a 100 nanosecond pulse. Adjust the pulse period VERNIER for a 10 microsecond period. Adjust the amplitude VERNIER for about a 3V pulse amplitude (TTL level).
4. Press [**INSTR PRESET**] on both the 8340A under test and the local oscillator 8340A. Press the 8340A under test [**CW**] key and enter [**1**] [**GHz**]. Press [**POWER LEVEL**] and enter [**–**] [**1**] [**0**] [**dBm**]. Press the local oscillator 8340A [**CW**] key and enter [**.**] [**9**] [**5**] [**GHz**]. The IF frequency is then 50 MHz. Set the local oscillator 8340A for +10 dBm or maximum leveled output.
5. Set the oscilloscope horizontal for 50 nanoseconds/division and select channel A input only. Adjust the channel A (IF carrier input signal) vertical sensitivity to view the entire RF envelope.

NOTE

It may be necessary to reduce the vertical sensitivity and/or adjust the 8340A RF output level at some frequencies.

6. Press the [**PULSE**] key on the 8340A under test (pulse ON). Adjust the oscilloscope vertical position and sensitivity to place the modulation envelope on convenient horizontal graticule lines. Press the [**PULSE**] key to turn pulse OFF. Press the [**POWER LEVEL**] key on the 8340A under test. Note the power level in the **ENTRY DISPLAY**.
7. Adjust the 8340A under test power level using the rotary knob so that the IF carrier signal aligns with the horizontal graticule lines established in step 6 for the modulation envelope. Note the **ENTRY DISPLAY** power level.
8. The difference between the power levels noted in step 6 and 7 should be less than the specification for this pulse width and RF frequency.
9. Repeat steps 5 through 8 for pulse widths of 200, 500, and 1000 nanoseconds.

4-21. PULSE MODULATION ACCURACY TEST (Cont'd)

10. To test the Pulse Repetition Frequency range (100 Hz to 5 MHz), set the pulse generator period to 10 milliseconds (100 Hz) and pulse width to 1 microsecond (duty cycle of 0.01%). Repeat steps 5 through 8. Set the pulse generator period to 200 nanoseconds (5 MHz) and pulse width to 100 nanoseconds (minimum specified PW). Repeat steps 5 through 8.
11. Set the pulse generator period to 10 microseconds and pulse width to 100 nanoseconds. Repeat steps 5 through 10 at CW frequencies of 3, 9, 15, and 22 GHz. Set the local oscillator 8340A CW frequency to be 50 MHz below the 8340A under test frequency. For 8340A under test frequencies of 15 and 22 GHz press **[PEAK]** to ON.

4-22. PULSE MODULATION VIDEO FEEDTHROUGH TEST

NOTE

THIS TEST IS NOT APPLICABLE TO INSTRUMENTS EQUIPPED WITH OPTION 006, DELETE PULSE MODULATION

Specification

Table 4-26. Pulse Modulation Video Feedthrough Test Specification

| | |
|--|---|
| For CW mode and frequencies ≥ 400 MHz only: | |
| Video Feedthrough (V_F/V_P): | |
| 0.4 to < 2.3 GHz (Band 0): | $< 5\%$ for output power levels $\leq +8$ dBm |
| 2.3 to 26.5 GHz (Bands 1-4): | $\leq 0.2\%$ |

Description

NOTE

Video feedthrough is any component of the pulse generator signal that appears at the 8340A RF output connector.

The 8340A under test is set to a CW frequency at 0 dBm. The 8340A is pulsed using a pulse generator. The pulsed RF output signal is fed through a 10 dB attenuator and a low pass filter that will pass only the low frequency (video feedthrough) component of the modulation envelope. The video feedthrough is measured using an oscilloscope. The measured voltage is related to the RF power by:

$$P = 10 \log (V^2/R/1 \text{ mW})$$

Where:

P = 8340A RF output level minus 10 dB, and

R = 50 Ohms.

Equipment

| | |
|-----------------------------|-------------------|
| Pulse Generator | HP 8012B |
| Oscilloscope | HP 1741A |
| Adapter | HP 5061-5311 |
| 10 dB Attenuator | HP 8493C Opt. 010 |
| Low Pass Filter (LPF) | HP P/N 9135-0260 |

Procedure

1. Connect equipment as shown in Figure 4-17. Attach the BNC tee directly to the 8340A PULSE input connector. Allow at least 30 minutes warm up time.

4-22. PULSE MODULATION VIDEO FEEDTHROUGH TEST (Cont'd)

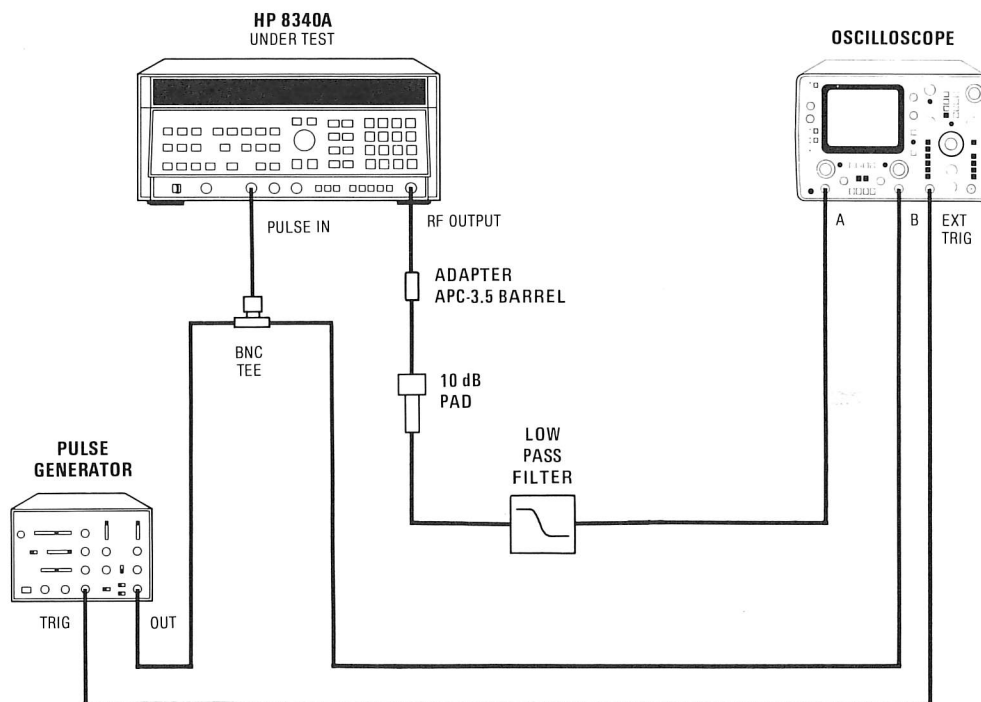

Figure 4-17. Pulse Modulation Video Feedthrough Test Setup

2. Set up the 8012B Pulse Generator as follows:

| | |
|-----------------------------------|--------------------|
| PULSE PERIOD slide switch | 1μ-1m |
| TRANSITION TIME slide switch..... | minimum (5n) |
| AMPLITUDE slide switch..... | top position (5.0) |
| PULSE DOUBLE/NORMAL..... | NORMAL |
| PULSE DELAY slide switch | minimum |
| Pulse Delay VERNIER fully | CCW |
| LEADING EDGE control..... | fully CCW |
| PULSE WIDTH slide switch..... | 10n-1μ |
| TRAILING EDGE control..... | fully CCW |
| OFFSET..... | OFF |
| POLARITY..... | + |
| OUTPUT..... | NORMAL |
| INT LOAD | IN |

3. Set both oscilloscope channels (A and B) to 50 Ohm input. Set the oscilloscope to view the pulse generator output waveform. Adjust the 8012B pulse width VERNIER for a 100 nanosecond pulse. Adjust the pulse period VERNIER for a 100 microsecond period. Adjust the amplitude VERNIER for about a 3V pulse amplitude (TTL level). Set the oscilloscope horizontal for 50 nanoseconds/division and select channel A input only.
4. Press **[INSTR PRESET]** on the 8340A under test. Press the 8340A **[CW]** key and enter **[.] [5] [GHz]**. Press the **[PULSE]** key (pulse ON).
5. Press the **[POWER LEVEL]** key enter the first power level, **[8] [dBm]**.
6. Adjust the oscilloscope channel A vertical sensitivity and vertical position to view the video feedthrough signal similar to Figure 4-18.

4-22. PULSE MODULATION VIDEO FEEDTHROUGH TEST (Cont'd)

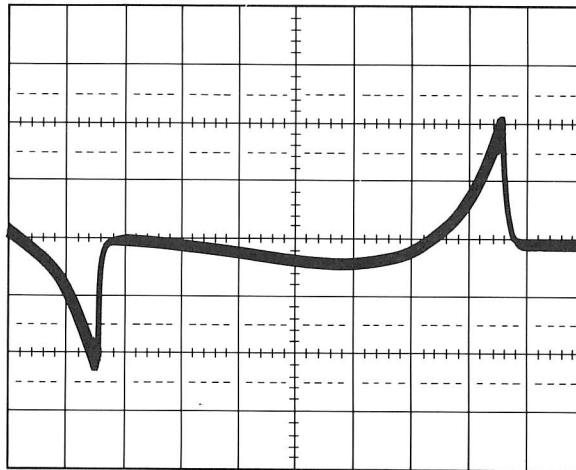

Figure 4-18. Pulse Modulation Video Feedthrough Waveform.

7. The test limits for the three power levels are shown in Table 4-27. (Note that the test limit is 5% of V_{pk} .)

Table 4-27. Pulse Modulation Video Feedthrough Test Limits

| 8340A RF Output Level (dBm) | P = (dBm) | V_{pk} | TEST LIMIT (pk voltage) |
|-----------------------------------|--------------|----------|-------------------------------|
| +8 | -2 | 0.2511 | 12 mV |
| 0 | -10 | 0.0999 | 5 mV |
| -10 | -20 | 0.03162 | 1.6 mV |

The test limits are derived using the following equation:

$$P = 10 \log (V_{rms}^2/R/1 \text{ mW})$$

Where:

P = 8340A RF output level -10 dB, and,

R = 50 Ohms.

Example:

4-22. PULSE MODULATION VIDEO FEEDTHROUGH TEST (Cont'd)

For 8340A set to 0 dBm the output of the 10 dB pad is -10 dBm.

$$P = 10 \log (V_{\text{rms}}^2/R/1 \text{ mW})$$

$$-10 = 10 \log (V^2/50/0.001) \quad (\text{divide through by 10})$$

$$-1 = \log (V^2/50/0.001) \quad (\text{take antilog of both sides})$$

$$10^{-1} = 0.1 = (V^2/50/0.001) \quad (\text{cross multiply})$$

$$0.0001 = V^2/50 \quad (\text{cross multiply again})$$

$$\sqrt{0.005} = V = 0.0707 \text{ rms}$$

$$\text{Test Limit} = V_{\text{pk}} \times 5\% = 0.0707 \times 1.414 \times 5\% = 5 \text{ mV}$$

8. Repeat steps 6 and 7 for 8340A output power levels of 0 and -10 dBm.
9. Repeat steps 5 through 8 at CW frequencies of 1, 1.5, and 2 GHz.

NOTE

For 8340A frequencies above 2.3 GHz the video feedthrough is typically so small that it is difficult to measure. The following steps provide a means to verify that the video feedthrough is negligible.

10. Remove the 10 dB pad between the 8340A Under Test and the low pass filter. Press the 8340A **[CW]** key and enter any frequency from >2.3 GHz to 26.5 GHz. Press the **[POWER LEVEL]** key and enter **[-] [1] [0] [dBm]**.
11. Select the oscilloscope X5 vertical magnifier. The test limit is now 0.2 mV or 1 minor division on the oscilloscope.
12. Select several 8340A CW frequencies >2.3 GHz and verify that the video feedthrough is less than 1 minor division on the oscilloscope.

4-23. AMPLITUDE MODULATION TEST

Specification

Table 4-28. Amplitude Modulation Test Specifications

The following specifications apply when the 8340A is internally leveled, for waveforms whose envelope peak is at least 1 dB below maximum specified power. Unless noted, pulse modulation must be OFF; however, the 8340A is capable of simultaneous amplitude and pulse modulation. See Section III, Operation.

AM Depth: 0 to 90%

AM Sensitivity at 1 kHz rate and 30% depth: 100%/Volt \pm 5%

AM Bandwidth relative t 1 kHz rate at 30% Depth:DC coupled, 3 dB point \geq 100 kHz

AM Frequency Response (Flatness) Relative to a 1 kHz rate at 30% depth, DC to 10 kHz:
 ± 0.20 dB

Description

AM sensitivity and accuracy is determined by simulating a modulation signal (i.e., setting the function generator to a dc voltage). The unmodulated 8340A RF output is measured using a power meter. A dc voltage representing $\pm 30\%$ modulation (± 0.3 Vdc) is applied to the 8340A under test AM input. The power meter indication should change by:

$$20 \log (1 + (\text{dc voltage} \pm (0.05 \text{ times the dc voltage})))$$

The sensitivity and accuracy is tested at several 8340A CW frequencies.

The AM frequency response and bandwidth is measured by down converting the 8340A under test RF frequency to an IF frequency within the range of the modulation analyzer. The 8340A is amplitude modulated using a function generator. The modulation analyzer is set to indicate 0 dB at the reference modulation frequency of 1 kHz. The modulation frequency is varied and the flatness is indicated on the modulation analyzer. The modulating frequency is then set to the bandwidth specification (100 kHz) and the modulation analyzer should indicate > -3 dB. This shows that the actual 3 dB point will occur at a frequency > 100 kHz.

Finally, the function generator output level is increased to obtain $> 90\%$ modulation depth.

4-23. AMPLITUDE MODULATION TEST (Cont'd)

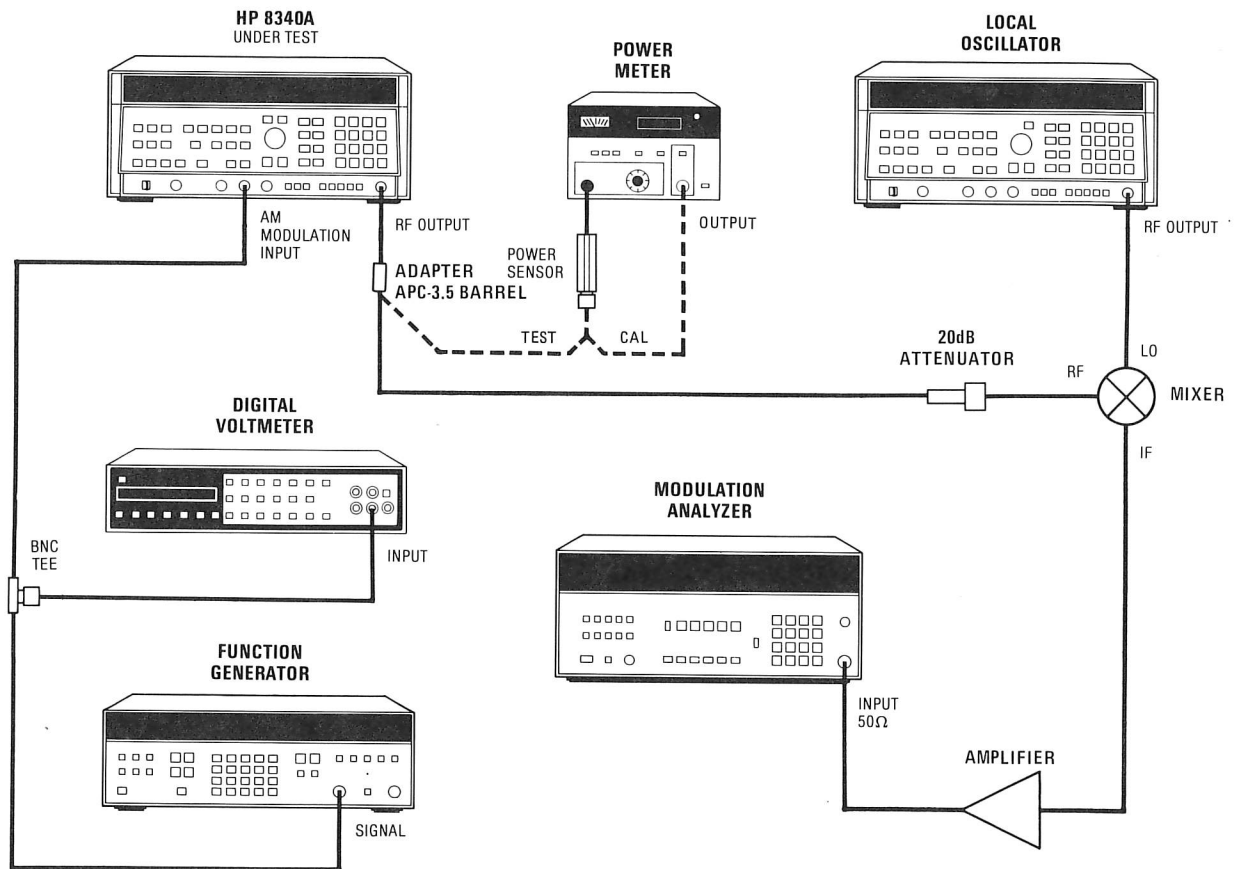

Figure 4-19. Amplitude Modulation Test Setup

Equipment

| | |
|--------------------------|--|
| Local Oscillator | HP 8340A Opt. 001 |
| Modulation Analyzer..... | HP 8901A |
| Function Generator..... | HP 3325A |
| Digital Voltmeter | HP 3455A |
| Amplifier..... | HP 8447F |
| Power Meter..... | HP 436A |
| Power Sensor..... | HP 8485A |
| Adapter | HP Part No. 5061-5311 (APC 3.5 female to female barrel) |
| 20 dB Attenuator | HP 8493C Opt. 020 |
| Mixer | RHG DMS 1-26 |

Procedure

AM SENSITIVITY AND ACCURACY

1. Connect equipment as shown in Figure 4-19. Connect the mixer LO port at the local oscillator 8340A RF output. Connect the 8485A Power Sensor to the power meter. Allow at least 30 minutes warm up time. Set the power meter's calibration factor switch to

4-23. AMPLITUDE MODULATION TEST (Cont'd)

include 1.5 GHz, then zero and calibrate the power meter. Connect the power sensor to the 8340A under test RF output.

2. Press 8340A under test [INSTR PRESET]. Press the [CW] key and enter [1] [.] [5] [GHz]. Press the [POWER LEVEL] key and enter [−] [5] [dBm].

NOTE

The function generator output impedance is 50 Ohms and its output indication accuracy assumes a 50 Ohm load. The 8340A AM input impedance is 600 Ohms; therefore, a high impedance DVM is used to measure and set the function generator output level.

3. Zero the power meter as follows:

With power applied to the sensor, press the power meter RANGE HOLD. Press the 8340A [RF] key to turn the RF OFF. Zero the power meter. Press the [RF] key to turn the RF ON.

4. Using the DVM as an indicator, set the function generator to output 0 Vdc (If the function generator being used does not have this feature, use a dc power supply). Press the 8340A under test [AM] key (AM ON). Note the power meter indication.
5. Simulate +30% modulation by setting the function generator output to +0.3 volts dc as indicated on the DVM. The power meter indication should increase by 2.18 to 2.38 dB from the value noted in step 4.

$$20 \log (1 + (0.3 - (0.05 \text{ times } 0.3))) = 2.18 \text{ dB}$$

to

$$20 \log (1 + (0.3 + (0.05 \text{ times } 0.3))) = 2.38 \text{ dB}$$

6. Simulate −30% modulation by setting the function generator output to −0.3 volts dc as indicated on the DVM. The power meter should decrease by 2.91 to 3.29 dB from the value noted in step 4.

$$20 \log (1 + (-0.3 - (0.05 \text{ times } -0.3))) = -2.91 \text{ dB}$$

to

$$20 \log (1 + (-0.3 + (0.05 \text{ times } -0.3))) = -3.29 \text{ dB}$$

NOTE

The 8340A test power levels are selected to avoid power meter range changes at the +30 and −30% modulation settings.

7. Press the 8340A under test [POWER LEVEL] key and enter [+] [5] [dBm]. Press the [AM] key to turn AM OFF. Repeat steps 3 through 6 for this 8340A power level setting.

4-23. AMPLITUDE MODULATION TEST (Cont'd)

8. Press the 8340A under test [CW] key and enter [4] [.] [5] [GHz]. Press the [AM] key to turn AM OFF. Set the power meter's calibration factor switch to include 4.5 GHz. Repeat steps 3 through 6 for 8340A power level settings of -5 and +5 dBm.

AM FREQUENCY RESPONSE AND BANDWIDTH

9. Disconnect the power sensor and connect the 8340A under test RF output to the 20 dB attenuator.
10. Press the 8340A under test [CW] key and enter [1] [.] [5] [GHz]. Press the [POWER LEVEL] key and enter [0] [dBm]. Press the local oscillator INSTR PRESET, CW and enter 1.45 GHz. Press POWER LEVEL, enter 10 dBm, and press PEAK (ON). (The output may be unlevelled; this will not affect the test.) The IF frequency is now 50 MHz.

NOTE

For best accuracy in the Amplitude Modulation test, the Local Oscillator drive to the mixer should be $\geq +6$ dBm. The 8340A Option 001 used as the LO will typically produce +6 dBm at any frequency, although it is only guaranteed to produce +4 dBm above 23 GHz. If +6 dBm is not available at a test frequency, try a slightly different frequency and be sure to have PEAK on.

11. Set the function generator for a sine wave at a reference frequency of 1 kHz at 0.2121 Vrms (0.3 times 0.707) ± 0.05 Vrms. For example: 0.25 Vrms, as indicated on the DVM, would fall in this range. Set the modulation analyzer input frequency to 50 MHz (by pressing FREQ 50 MHz), then press AM and AVE. The modulation analyzer should indicate about 21%. Note the DVM indication.
12. Press the dB key. As the modulating frequency is changed the modulation analyzer will indicate the flatness in dB relative to the 1 kHz reference.
13. Set the function generator to 100, 200, 500 Hz, then 1, 2, 5, and 10 kHz. Check the DVM indication and adjust the level of the modulating signal at each frequency to eliminate any flatness error of the function generator. Observe the flatness indication on the modulation analyzer. The flatness indication should be $\leq \pm 0.20$ dB.
14. Check the AM bandwidth by setting the function generator to 100 kHz. Adjust the function generator output level to the value noted in step 11. The modulation analyzer should indicate ≥ -3 dB.

AM DEPTH

15. Set the function generator to 1 kHz. Set the modulation analyzer to indicate percent modulation by setting the controls as follows:

| | |
|--------------------------|-----|
| AUTOMATIC OPERATION..... | ON |
| AM..... | ON |
| RATIO %..... | OFF |
| RATIO dB..... | OFF |
| PEAK..... | + |

4-23. AMPLITUDE MODULATION TEST (Cont'd)

Increase the function generator output amplitude to obtain >90% modulation depth.

16. Repeat steps 11 through 15 at 8340A RF frequencies of 3, 9, 15, and 22 GHz. Set the local oscillator 8340A CW frequency to be 50 MHz below the 8340A under test frequency.

4-24. 8340A HP-IB OPERATION VERIFICATION TEST

NOTE

This HP-IB test is an automated test; a Desktop Computer is required.

Two software listings are supplied. Table 4-30 gives a BASIC program listing for the HP 85F; Table 4-31 gives a BASIC program listing for the HP 9826A or 9836A and 4-16. The test procedure applies to either test program used.

Description

The test program given in Table 4-30 is written to verify the 8340A HP-IB interface by writing to and reading from the 8340A. The program also displays the 8340A status bytes similar to the format shown in Table 4-29, 8340A Status Byte Descriptions. Upon running the program the status bits displayed will change initially as the program outputs an IP (INSTR PRESET), S2 (Single sweep), and two TS (Take Sweep) commands. After about two passes through the output loop (program lines 120 to 300 for the HP 85F, program lines 130 to 350 for the HP 9826A/9836A), the status bits should all be zero's and the 8340A should be in LOCAL mode. The procedure instructs the operator to press specific 8340A front panel keys and perform certain functions which should set specific bits of the status bytes. This procedure will test most of the bits in the two status bytes. However, if the 8340A is working properly, the status bit for the Fault Indicator On, the Oven Cold, and the Self Test Failed will not be tested for the set state. By pressing a controller soft key, the program will test the data bits by outputting a series of binary numbers to the 8340A and reading back each number that it outputs. If a bit is held HIGH or LOW, the number read will not agree with the number written and the program will display an error message. This procedure does not test all of the HP-IB control lines.

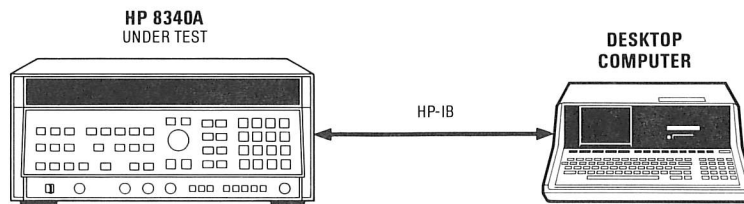

Figure 4-20. 8340A HP-IB Operation and Verification Test Setup

Equipment

- Desktop Computer HP 85F
 (Includes HP 82937A HP-IB Interface and
 I/O ROM HP P/N 00085-15002 and
 HP 82936 ROM Drawer)
- Plotter/Printer ROM..... HP P/N 00085-15002

OR

- Desktop Computer..... HP 9826A/9836A
 (With BASIC language and 512K byte memory)

4-24. 8340A HP-IB OPERATION VERIFICATION TEST (Cont'd)**Procedure**

1. Connect the equipment as shown in Figure 4-20. Enter the program shown in Table 4-30 if the HP 85F is used, or the program in Table 4-31 if the HP 9826A or 9836A is used. Press the RUN key. The program will display the 8340A status bytes similar to Table 4-29. After the program goes through the output loop routine about two times, all status bits should be "0" and the 8340A should be in LOCAL mode (front panel REMOTE indicator not ON).
2. Press the 8340A [INSTR PRESET] key. After going through the output loop about three times, status byte 1 decimal value should be 24 (bits 4 and 3 set).

NOTE

After pressing an 8340A front panel key, watch the displayed decimal value. When the decimal value changes, press the controller PAUSE key. Note the status bits that are set and press CONT.

3. Press the 8340A [CW] key. After the program goes through the output loop about three times all status bits should be "0"; however, status byte 1, bit 1, should have been set during one of the output loop passes. Enter [1] [5] [GHz] and the byte 1 status bits will change, but after about 2 passes all status bits should be "0".
4. Press the [POWER LEVEL] key and increase the 8340A output power level using the rotary knob until the UNLEVELED light comes on. Status byte 2 decimal value should be 64 (bit 6 set). Decrease the output power level until the UNLEVELED light goes out. All status bits should be "0".
5. Switch the 8340A rear panel FREQUENCY REFERENCE switch to EXT. Status byte 2 value should be 24 (bits 4 and 3 set). Return the switch to INT.
6. Press the controller softkey K1 (SYNTAX).

NOTE

There will be about a 6 second delay before the status bits change.

The program will output the character string "XYZ" to the 8340A. The 8340A should not recognize this string and should set status byte 1, bit 5 (SRQ on HP-IB Syntax Error).

7. Press the controller softkey K4 (DATA BIT). The program will test all data bits and display an error message if any bits fail the test, or if all bits pass the test, the program will display "ALL DATA BITS WORKING".

4-24. 8340A HP-IB OPERATION VERIFICATION TEST (Cont'd)

Table 4-29. 8340A Status Byte Description

| STATUS BYTE (#1) | | | | | | | | |
|----------------------------------|--|-----------------------|---------------------------|---------------------|------------------------------|--|---|------------------------------------|
| BIT # | 7 | 6 | 5 | 4 | 3 | 2 | 1 | 0 |
| DECIMAL VALUE | 128 | 64 | 32 | 16 | 8 | 4 | 2 | 1 |
| FUNCTION | SRQ on New frequencies or Sweep Time in Effect | REQUEST SERVICE (RQS) | SRQ on HP-IB Syntax Error | SRQ on End of Sweep | SRQ on RF Settled | SRQ on Changed in Extended Status Byte | SRQ on Numeric Entry Completed (HP-IB or Front Panel) | SRQ on Any Front Panel Key Pressed |
| EXTENDED STATUS BYTE (#2) | | | | | | | | |
| BIT # | 7 | 6 | 5 | 4 | 3 | 2 | 1 | 0 |
| DECIMAL VALUE | 128 | 64 (L) | 32 (L) | 16 (L) | 8 | 4 | 2 | 1 (L) |
| FUNCTION | Fault Indicator On | RF Unleveled | Power Failure | RF Unlocked | External Freq. Ref. Selected | Oven Cold | Over Modulation | Self Test Failed |
| (L) See Note 3 | | | | | | | | |

Table 4-30. 8340A HP-IB Operation Verification Programming Listing (For Use With HP 85F)

```

10      ! 8340A HP-IB OPERATION VERIFICATION
20      !   VERIFICATION TEST
30      !
40      !       14 SEPT 82
50      !
60      I1=719
70      OUTPUT I1 ;"IP S2 TSTS"
80      !
90      ON KEY# 1,"SYNTAX" GOSUB 370
100     ON KEY# 4,"DATA BIT" GOSUB 400
110     LOCAL 7
120     OUTPUT I1 ;"OS"
130     DISP "8340A STATUS BYTE 1 AND 2"
140     DISP
150     DISP "BYTE -----BIT-----"
160     DISP "# 7 6 5 4 3 2 1 0 VALUE"
170     DISP "-----"
180     DISP
190     ENTER I1 USING "#,B" ; E,F
200     FOR I=1 TO 2
210     DISP I;
220     IF I=1 THEN N=E
230     IF I=2 THEN N=F
240     FOR J=7 TO 0 STEP -1
250     A=BIT(N,J)
260     DISP A;
270     NEXT J
280     DISP N
290     DISP
300     NEXT I
310     DISP USING "4/,A" ; " "
320     KEY LABEL
330     GOTO 120
340     !
350     ! Syntax Test
360     !
370     OUTPUT I1 ; "XYZ"
380     RETURN
390     !
400     ! Test Data Bits
410     !
420     CLEAR
430     DSP USNG "/,K" ; "   TEST DATA BITS"
440     FOR C=0 TO 7
450     B=2^C
460     OUTPUT I1 USING "K,B" , "TI",B
470     WAIT 100
480     ENTER I1 USING "#,B" , D
490     IF B#D THEN DISP "   DATA BIT";C;"NOT WORKING"
500     NEXT C
510     DISP "ALL DATA BITS WORKING"
520     DISP "PRESS CONT"
530     PAUSE
540     RETURN
550     END

```

Table 4-31. 8340A HP-IB Operation Verification Programming Listing (for use with HP 9826A or 9836A)

```

10      ! 8340A HP-IB OPERATION
20      ! VERIFICATION TEST
30      !
40      !   7 APRIL 83
50      !
60      I1=719
70      OUTPUT I1;"IP S2 TSTS"
80      !
90      OFF KEY
100     ON KEY 1 LABEL "SYNTAX" GOTO Syntax
110     ON KEY 4 LABEL "DATA BIT" GOTO Data_bit
120     LOCAL 7
130     OUTPUT 1;CHR$(12);
140     !
150     Read_status: !
160     OUTPUT I1;"OS"
170     !
180     PRINT TABXY(1,1);"8340A STATUS BYTE 1 AND 2"
190     PRINT
200     PRINT "BYTE -----BIT-----"
210     PRINT "# 7 6 5 4 3 2 1 0 VALUE"
220     PRINT "-----"
230     PRINT
240     ENTER I1 USING "#,B";E,F
250     FOR I=1 TO 2
260         PRINT I;
270         IF I=1 THEN N=E
280         IF I=2 THEN N=F
290         FOR J=7 TO 0 STEP -1
300             A=BIT(N,J)
310             PRINT A;
320         NEXT J
330         PRINT USING "X,5D";N
340         PRINT
350     NEXT I
360     BEEP 200,.01
370     GOTO Read_status
380     !
390     Syntax: !
400     !
410     OUTPUT I1;"XYZ"
420     GOTO Read_status
430     !
440     Data_bit: !
450     !
460     OUTPUT 1;CHR$(12); ! Clear screen
470     DISP USING "/,K";" TEST DATA BITS"
480     FOR C=0 TO 7
490         B=2^C
500         OUTPUT I1 USING "K,B";"TI",B
510         WAIT .1
520         ENTER I1 USING "#,B";D
530         IF B-D<1 THEN GOTO 550
540         IF B<>D THEN DISP " DATA BIT ";C;" NOT WORKING"
550     NEXT C
560     !
570     PRINT "ALL DATA BITS WORKING"
580     DISP "PRESS CONTINUE"
590     PAUSE
600     DISP
610     GOTO Read_status
620     END

```

Table 4-32. 8340A Test Record Card (1 of 27)

| <div style="display: flex; justify-content: space-between;"> <div style="width: 60%;"> <p>Hewlett-Packard Model 8340A Synthesized Sweeper</p> </div> <div style="width: 35%;"> <p>Date: _____</p> </div> </div> <div style="display: flex; justify-content: space-between;"> <div style="width: 45%;"> <p>Serial Number: _____</p> </div> <div style="width: 45%;"> <p>Tested By: _____</p> </div> </div> | | | | | |
|---|----------------------------|--------------------|----------------|---|----------------|
| SPECIFICATIONS TESTED Limits | Step | TEST Conditions | Lower Limit | Measured Value | Upper Limit |
| <p>4-9. Internal Time Base Aging Rate T_1 = Time for 360 degree phase change T_2 = Time between T_1 and T_3 T_3 = Time for 360 degree phase change Calculated Aging Rate</p> | <p>3</p> <p>4</p> <p>5</p> | | | <p>_____ seconds</p> <p>_____ hours</p> <p>_____ seconds</p> <p>_____ per day</p> | |

Table 4-32. 8340A Test Record Card (2 of 27)

| SPECIFICATIONS TESTED Limits | Step | TEST Conditions | Lower Limit | Measured Value | Upper Limit |
|---|------|---|----------------|-------------------|----------------|
| 4-10. Frequency Range and CW Mode Accuracy | | | | | |
| Frequency Range Check | | | | | |
| 10 MHz | 2 | Freq. ± 1 Hz \pm Counter Resolution | | _____ MHz | |
| 26.5 GHz | 3 | Freq. ± 4 Hz \pm Counter Resolution | | _____ GHz | |
| M/N Divider Check (M Divider) | 4b | Freq. ± 1 Hz \pm Counter Resolution | | | |
| M = 8 N = 13 | | 2490 MHz | | _____ MHz | |
| 9 | | 2480 MHz | | _____ MHz | |
| 10 | | 2470 MHz | | _____ MHz | |
| 11 | | 2460 MHz | | _____ MHz | |
| 12 | | 2450 MHz | | _____ MHz | |
| 13 | | 2440 MHz | | _____ MHz | |
| 14 | | 2430 MHz | | _____ MHz | |
| 15 | | 2420 MHz | | _____ MHz | |
| 16 | | 2410 MHz | | _____ MHz | |
| 17 | | 2400 MHz | | _____ MHz | |
| 18 | | 2390 MHz | | _____ MHz | |
| 19 | | 2380 MHz | | _____ MHz | |
| 20 | | 2370 MHz | | _____ MHz | |
| 21 | | 2360 MHz | | _____ MHz | |
| 22 | | 2350 MHz | | _____ MHz | |
| 23 | | 2340 MHz | | _____ MHz | |
| 24 | | 2330 MHz | | _____ MHz | |
| 25 | | 2320 MHz | | _____ MHz | |
| 26 | | 2310 MHz | | _____ MHz | |
| 27 | | 2300 MHz | | _____ MHz | |

Table 4-32. 8340A Test Record Card (4 of 27)

| SPECIFICATIONS TESTED Limits | Step | TEST Conditions | Lower Limit | Measured Value | Upper Limit |
|--|----------|--|----------------|-------------------|----------------|
| 4-10. Frequency Range and CW Mode Accuracy (cont'd) 20-30 Loop Check (N2 Divider) 8340A ENTRY DISPLAY CF Frequency: | | 8340A START Frequency Freq. ± 1 Hz \pm Counter Resolution | | | |
| | 6b | 2.310000 GHz | | _____ GHz | |
| | 6c | 2.310001 | | _____ GHz | |
| | | 2.310002 | | _____ GHz | |
| | | 2.310003 | | _____ GHz | |
| | | 2.310004 | | _____ GHz | |
| | | 2.310005 | | _____ GHz | |
| | | 2.310006 | | _____ GHz | |
| | | 2.310007 | | _____ GHz | |
| | | 2.310008 | | _____ GHz | |
| | | 2.310009 | | _____ GHz | |
| | | 2.310010 | | _____ GHz | |
| | 6d | 2.310010 | | _____ GHz | |
| | 6e | 2.310020 | | _____ GHz | |
| | | 2.310030 | | _____ GHz | |
| | | 2.310040 | | _____ GHz | |
| | | 2.310050 | | _____ GHz | |
| | | 2.310060 | | _____ GHz | |
| | | 2.310070 | | _____ GHz | |
| | | 2.310080 | | _____ GHz | |
| | | 2.310090 | | _____ GHz | |
| | | 2.310100 | | _____ GHz | |
| | 6f | 2.310100 | | _____ GHz | |
| | 6g | 2.310200 | | _____ GHz | |
| | | 2.310300 | | _____ GHz | |
| | | 2.310400 | | _____ GHz | |
| | | 2.310500 | | _____ GHz | |
| | | 2.310600 | | _____ GHz | |
| | | 2.310700 | | _____ GHz | |
| | | 2.310800 | | _____ GHz | |
| | | 2.310900 | | _____ GHz | |
| | | 2.311000 | | _____ GHz | |
| | | 2.311100 | | _____ GHz | |
| | | 2.311200 | | _____ GHz | |
| | | 2.311300 | | _____ GHz | |
| | | 2.311400 | | _____ GHz | |
| | | 2.311500 | | _____ GHz | |
| | 6h | 2.311000 | | _____ GHz | |
| | 6i | 2.312000 | | _____ GHz | |
| | | 2.313000 | | _____ GHz | |
| | | 2.314000 | | _____ GHz | |
| | 2.315000 | | _____ GHz | | |
| | 2.316000 | | _____ GHz | | |
| | 2.317000 | | _____ GHz | | |
| | 2.318000 | | _____ GHz | | |
| | 2.319000 | | _____ GHz | | |
| | 2.320000 | | _____ GHz | | |

Table 4-32. 8340A Test Record Card (6 of 27)

| SPECIFICATIONS TESTED Limits | Step | TEST Conditions | Lower Limit | Measured Value | Upper Limit |
|---|------|--------------------|--|---|---|
| 4-11. Sweep Time Accuracy 10 milliseconds 100 milliseconds 1 second 10 seconds 50 seconds | 4 | | 9.5 msec 95 msec 0.95 sec 9.5 sec 47.5 sec | _____ msec _____ msec _____ sec _____ sec _____ sec | 10.5 msec 105 msec 1.05 sec 10.5 sec 52.5 sec |

Table 4-32. 8340A Test Record Card (7 of 27)

| SPECIFICATIONS TESTED Limits | | Step | TEST Conditions | | Lower Limit | Measured Value | Upper Limit |
|--|------------------------|-----------|-----------------|------------------|--------------------------------------|------------------------------------|--------------------------------------|
| 4-12. Swept Frequency Accuracy 20% of Band Accuracy | | 8 | | | | | |
| 8340A Start Freq. (GHz) | 8340A Stop Freq. (GHz) | | 20% of Band | Test Limit (kHz) | Spectrum Analyzer Center Freq. (GHz) | Spectrum Analyzer Center Freq. GHz | Spectrum Analyzer Center Freq. (GHz) |
| 2.3 | 2.300099 | 2.3000198 | ± 0.99 | 2.30001881 | _____ | 2.30002079 | |
| 2.3 | 2.300101 | 2.3000202 | ± 1.01 | 2.30001919 | _____ | 2.30002121 | |
| 2.3 | 2.300499 | 2.3000998 | ± 4.99 | 2.30009481 | _____ | 2.30010479 | |
| 2.3 | 2.300501 | 2.3001002 | ± 5.01 | 2.30009519 | _____ | 2.30010521 | |
| 2.3 | 2.30499 | 2.300998 | ± 49.9 | 2.3009481 | _____ | 2.3010479 | |
| 2.3 | 2.30501 | 2.301002 | ± 100.02 | 2.30090198 | _____ | 2.30110202 | |
| 2.3 | 2.31 | 2.302 | ± 200 | 2.3018 | _____ | 2.3022 | |
| 2.3 | 2.32 | 2.304 | ± 400 | 2.3036 | _____ | 2.3044 | |
| 2.3 | 2.33 | 2.306 | ± 600 | 2.3054 | _____ | 2.3066 | |
| 2.3 | 2.34 | 2.308 | ± 800 | 2.3072 | _____ | 2.3088 | |
| 2.3 | 2.349 | 2.3098 | ± 998 | 2.308802 | _____ | 2.310798 | |
| 2.3 | 2.3501 | 2.31002 | ± 1020 | 2.309 | _____ | 2.31104 | |
| 2.3 | 2.36 | 2.312 | ± 1200 | 2.3108 | _____ | 2.3132 | |
| 2.3 | 2.37 | 2.314 | ± 1400 | 2.3126 | _____ | 2.3154 | |
| 2.3 | 2.38 | 2.316 | ± 1600 | 2.3144 | _____ | 2.3176 | |
| 2.3 | 2.39 | 2.318 | ± 1800 | 2.3162 | _____ | 2.3198 | |
| 2.3 | 2.3999 | 2.31998 | ± 1980 | 2.318 | _____ | 2.32196 | |
| 2.3 | 2.4001 | 2.32002 | ± 2002 | 2.318018 | _____ | 2.322022 | |
| 2.3 | 2.799 | 2.3998 | ± 4990 | 2.39481 | _____ | 2.40479 | |
| 2.3 | 2.801 | 2.4002 | ± 5010 | 2.39519 | _____ | 2.40521 | |
| 2.3 | 7.29 | 3.298 | ± 49900 | 3.2481 | _____ | 3.3479 | |
| 2.3 | 7.31 | 3.302 | ± 50000 | 3.352 | _____ | 3.352 | |
| 2.3 | 8.3 | 3.500 | ± 50000 | 3.45 | _____ | 3.55 | |
| 2.3 | 16.452 | 5.1304 | ± 50000 | 5.0804 | _____ | 5.1804 | |
| 2.3 | 24.55 | 6.75 | ± 50000 | 6.70 | _____ | 6.80 | |
| 2.3 | 26.5 | 7.14 | ± 50000 | 7.09 | _____ | 7.19 | |

Table 4-32. 8340A Test Record Card (8 of 27)

| SPECIFICATIONS TESTED Limits | | Step | TEST Conditions | | Lower Limit | Measured Value | Upper Limit |
|---|------------------------|-----------|-----------------|------------------|--------------------------------------|------------------------------------|--------------------------------------|
| 4-12. Swept Frequency Accuracy (Cont'd) 50% of Band Accuracy | | 8 | | | | | |
| 8340A Start Freq. (GHz) | 8340A Stop Freq. (GHz) | | 50% of Band | Test Limit (kHz) | Spectrum Analyzer Center Freq. (GHz) | Spectrum Analyzer Center Freq. GHz | Spectrum Analyzer Center Freq. (GHz) |
| 2.3 | 2.300099 | 2.3000495 | ± 0.99 | 2.30004851 | _____ | 2.30005049 | |
| 2.3 | 2.300101 | 2.3000505 | ± 1.01 | 2.30004949 | _____ | 2.30005151 | |
| 2.3 | 2.300499 | 2.3002495 | ± 4.99 | 2.30024451 | _____ | 2.30025449 | |
| 2.3 | 2.300501 | 2.3002505 | ± 5.01 | 2.30024549 | _____ | 2.30025551 | |
| 2.3 | 2.30499 | 2.302495 | ± 49.9 | 2.3024451 | _____ | 2.3025449 | |
| 2.3 | 2.30501 | 2.302505 | ± 100.02 | 2.30240498 | _____ | 2.30260502 | |
| 2.3 | 2.31 | 2.305 | ± 200 | 2.3048 | _____ | 2.3052 | |
| 2.3 | 2.32 | 2.310 | ± 400 | 2.3096 | _____ | 2.3104 | |
| 2.3 | 2.33 | 2.315 | ± 600 | 2.3144 | _____ | 2.3156 | |
| 2.3 | 2.34 | 2.320 | ± 800 | 2.3192 | _____ | 2.3208 | |
| 2.3 | 2.349 | 2.3245 | ± 998 | 2.323502 | _____ | 2.325498 | |
| 2.3 | 2.3501 | 2.32505 | ± 1020 | 2.32403 | _____ | 2.32607 | |
| 2.3 | 2.36 | 2.33 | ± 1200 | 2.3288 | _____ | 2.3312 | |
| 2.3 | 2.37 | 2.335 | ± 1400 | 2.3336 | _____ | 2.3364 | |
| 2.3 | 2.38 | 2.34 | ± 1600 | 2.3384 | _____ | 2.3416 | |
| 2.3 | 2.39 | 2.345 | ± 1800 | 2.3432 | _____ | 2.3468 | |
| 2.3 | 2.3999 | 2.34995 | ± 1980 | 2.34797 | _____ | 2.35193 | |
| 2.3 | 2.4001 | 2.35005 | ± 2002 | 2.348048 | _____ | 2.352052 | |
| 2.3 | 2.799 | 2.5495 | ± 4990 | 2.54451 | _____ | 2.55449 | |
| 2.3 | 2.801 | 2.5505 | ± 5010 | 2.54549 | _____ | 2.55551 | |
| 2.3 | 7.29 | 4.795 | ± 49900 | 4.7451 | _____ | 4.8449 | |
| 2.3 | 7.31 | 4.805 | ± 50000 | 4.755 | _____ | 4.855 | |
| 2.3 | 8.3 | 5.300 | ± 50000 | 5.250 | _____ | 5.350 | |
| 2.3 | 16.452 | 9.376 | ± 50000 | 9.326 | _____ | 9.426 | |
| 2.3 | 24.55 | 13.425 | ± 50000 | 13.375 | _____ | 13.475 | |
| 2.3 | 26.5 | 14.4 | ± 50000 | 14.35 | _____ | 14.45 | |

Table 4-32. 8340A Test Record Card (9 of 27)

| SPECIFICATIONS TESTED Limits | | Step | TEST Conditions | | Lower Limit | Measured Value | Upper Limit |
|---|------------------------|-----------|-----------------|------------------|--------------------------------------|------------------------------------|--------------------------------------|
| 4-12. Swept Frequency Accuracy (Cont'd) 80% of Band Accuracy | | 8 | | | | | |
| 8340A Start Freq. (GHz) | 8340A Stop Freq. (GHz) | | 80% of Band | Test Limit (kHz) | Spectrum Analyzer Center Freq. (GHz) | Spectrum Analyzer Center Freq. GHz | Spectrum Analyzer Center Freq. (GHz) |
| 2.3 | 2.300099 | 2.3000792 | ± 0.99 | 2.30007821 | _____ | 2.30008019 | |
| 2.3 | 2.300101 | 2.300808 | ± 1.01 | 2.30007979 | _____ | 2.30008181 | |
| 2.3 | 2.300499 | 2.3003992 | ± 4.99 | 2.30039421 | _____ | 2.30040419 | |
| 2.3 | 2.300501 | 2.3004008 | ± 5.01 | 2.30039579 | _____ | 2.30040581 | |
| 2.3 | 2.30499 | 2.303992 | ± 49.9 | 2.3039421 | _____ | 2.3040419 | |
| 2.3 | 2.30501 | 2.304008 | ± 100.02 | 2.30390798 | _____ | 2.3041802 | |
| 2.3 | 2.31 | 2.308 | ± 200 | 2.3078 | _____ | 2.3082 | |
| 2.3 | 2.32 | 2.316 | ± 400 | 2.3156 | _____ | 2.3164 | |
| 2.3 | 2.33 | 2.324 | ± 600 | 2.3234 | _____ | 2.3246 | |
| 2.3 | 2.34 | 2.332 | ± 800 | 2.3312 | _____ | 2.3328 | |
| 2.3 | 2.349 | 2.3392 | ± 998 | 2.338202 | _____ | 2.340198 | |
| 2.3 | 2.3501 | 2.34008 | ± 1020 | 2.33906 | _____ | 2.3411 | |
| 2.3 | 2.36 | 2.348 | ± 1200 | 2.3468 | _____ | 2.3492 | |
| 2.3 | 2.37 | 2.356 | ± 1400 | 2.3546 | _____ | 2.3574 | |
| 2.3 | 2.38 | 2.364 | ± 1600 | 2.3624 | _____ | 2.3656 | |
| 2.3 | 2.39 | 2.372 | ± 1800 | 2.3702 | _____ | 2.3738 | |
| 2.3 | 2.3999 | 2.37992 | ± 1980 | 2.37794 | _____ | 2.3819 | |
| 2.3 | 2.4001 | 2.38008 | ± 2002 | 2.378078 | _____ | 2.382082 | |
| 2.3 | 2.799 | 2.6992 | ± 4990 | 2.69421 | _____ | 2.70419 | |
| 2.3 | 2.801 | 2.7008 | ± 5010 | 2.69579 | _____ | 2.70581 | |
| 2.3 | 7.29 | 6.292 | ± 49900 | 6.2421 | _____ | 6.3419 | |
| 2.3 | 7.31 | 6.308 | ± 50000 | 6.258 | _____ | 6.358 | |
| 2.3 | 8.3 | 7.1 | ± 50000 | 7.05 | _____ | 7.15 | |
| 2.3 | 16.452 | 13.6216 | ± 50000 | 13.5716 | _____ | 13.6716 | |
| 2.3 | 24.55 | 20.1 | ± 50000 | 20.55 | _____ | 20.15 | |
| 2.3 | 26.5 | 21.66 | ± 50000 | 21.61 | _____ | 21.71 | |

Table 4-32. 8340A Test Record Card (10 of 27)

| SPECIFICATIONS TESTED Limits | Step | TEST Conditions | Lower Limit | Measured Value | Upper Limit |
|--|------|--|-------------|----------------|-------------|
| 4-13. Maximum Leveled Output Power and Power Accuracy | | | | | |
| Maximum Leveled Power Band 0 | | | | | |
| ENTRY DISPLAY Power Indication | 3 | Continuous Sweep, Auto Sweep Time | | _____ dBm | |
| | 4 | Single Sweep, Auto Sweep Time | | _____ dBm | |
| | 5 | Single Sweep, 2 Second Sweep Time | | _____ dBm | |
| Lowest power level recorded in step 3, 4, or 5 | 6 | | | _____ dBm | |
| Minimum Power Frequency | | M2 Frequency | | _____ GHz | |
| Power Meter Indication | 7 | Standard Instrument (F.P. Out with Atten.) | +10 dBm | _____ dBm | |
| | | Option 001 (F.P. Out No Atten.) | +10 dBm | _____ dBm | |
| | | Option 004 (R.P. Out with Atten.) | +10 dBm | _____ dBm | |
| | | Option 005 (R.P. Out No Atten.) | +10 dBm | _____ dBm | |
| Maximum Leveled Power Band 1 | | | | | |
| ENTRY DISPLAY Power Indication | 3 | Continuous Sweep, Auto Sweep Time | | _____ dBm | |
| | 4 | Single Sweep, Auto Sweep Time | | _____ dBm | |
| | 5 | Single Sweep, 2 Second Sweep Time | | _____ dBm | |
| Lowest power level recorded in step 3, 4, or 5 | 6 | | | _____ dBm | |
| Minimum Power Frequency | | M2 Frequency | | _____ GHz | |
| Power Meter Indication | 7 | Standard Instrument (F.P. Out with Atten.) | +12 dBm | _____ dBm | |
| | | Option 001 (F.P. Out No Atten.) | +13 dBm | _____ dBm | |
| | | Option 004 (R.P. Out with Atten.) | +11 dBm | _____ dBm | |
| | | Option 005 (R.P. Out No Atten.) | +12 dBm | _____ dBm | |

Table 4-32. 8340A Test Record Card (11 of 27)

| SPECIFICATIONS TESTED Limits | Step | TEST Conditions | Lower Limit | Measured Value | Upper Limit |
|---|------|--|-------------|----------------|-------------|
| 4-13. Maximum Leveled Output Power and Power Accuracy (cont'd) | | | | | |
| Maximum Leveled Power Band 2 | | | | | |
| ENTRY DISPLAY Power Indication | 3 | Continuous Sweep, Auto Sweep Time | | _____ dBm | |
| | 4 | Single Sweep, Auto Sweep Time | | _____ dBm | |
| | 5 | Single Sweep, 2 Second Sweep Time | | _____ dBm | |
| Lowest power level recorded in step 3, 4, or 5 | 6 | | | _____ dBm | |
| Minimum Power Frequency | | M2 Frequency | | _____ GHz | |
| Power Meter Indication | 7 | Standard Instrument (F.P. Out with Atten.) | +10 dBm | _____ dBm | |
| | | Option 001 (F.P. Out No Atten.) | +12 dBm | _____ dBm | |
| | | Option 004 (R.P. Out with Atten.) | +9 dBm | _____ dBm | |
| | | Option 005 (R.P. Out No Atten.) | +11 dBm | _____ dBm | |
| Maximum Leveled Power Band 3 | | | | | |
| ENTRY DISPLAY Power Indication | 3 | Continuous Sweep, Auto Sweep Time | | _____ dBm | |
| | 4 | Single Sweep, Auto Sweep Time | | _____ dBm | |
| | 5 | Single Sweep, 2 Second Sweep Time | | _____ dBm | |
| Lowest Power level recorded in step 3, 4, or 5 | 6 | | | _____ dBm | |
| Minimum Power Frequency | | M2 Frequency | | _____ GHz | |
| Power Meter Indication | 7 | Standard Instrument (F.P. Out with Atten.) | +9 dBm | _____ dBm | |
| | | Option 001 (F.P. Out No Atten.) | +11 dBm | _____ dBm | |
| | | Option 004 (R.P. Out with Atten.) | +7 dBm | _____ dBm | |
| | | Option 005 (R.P. Out No Atten.) | +9 dBm | _____ dBm | |

Table 4-32. 8340A Test Record Card (12 of 27)

| SPECIFICATIONS TESTED Limits | Step | TEST Conditions | Lower Limit | Measured Value | Upper Limit |
|--|------|---|----------------|-------------------|----------------|
| 4-13. Maximum Leveled Output Power and Power Accuracy (cont'd) | | | | | |
| Maximum Leveled Power Band 4 (20-23 GHz) ENTRY DISPLAY Power Indication | 3 | Continuous Sweep, Auto Sweep Time | | _____ dBm | |
| | 4 | Single Sweep, Auto Sweep Time | | _____ dBm | |
| | 5 | Single Sweep, 2 Second Sweep Time | | _____ dBm | |
| Lowest power level recorded in step 3, 4, or 5 | 6 | | | _____ dBm | |
| Minimum Power Frequency | | M2Frequency | | _____ GHz | |
| Power Meter Indication | 7 | Standard Instrument (F.P. out with Atten.) | +3 dBm | _____ dBm | |
| | | Option 001 (F.P. Out No Atten.0) | +6 dBm | _____ dBm | |
| | | Option 004 (R.P. Out with Atten.) | +1 dBm | _____ dBm | |
| | | Option 005 (R.P. Out No Atten.) | +4 dBm | _____ dBm | |
| Maximum Leveled Power Band 4 (23-26.5 GHz) ENTRY DISPLAY Power Indication | 3 | Continuous Sweep, Auto Sweep Time | | _____ dBm | |
| | 4 | Single Sweep, Auto Sweep Time | | _____ dBm | |
| | 5 | Single Sweep, 2 Second Sweep Time | | _____ dBm | |
| Lowest power level recorded in step 3, 4, or 5 | 6 | | | _____ dBm | |
| Minimum Power Frequency | | M2 Frequency | | _____ GHz | |
| Power Meter Indication | 7 | Standard Instrument (F.P. Out with Atten.) | +1 dBm | _____ dBm | |
| | | Option 001 (F.P. Out No Atten.) | +4 dBm | _____ dBm | |
| | | Option 004 (R.P. Out with Atten.) | -1 dBm | _____ dBm | |
| | | Option 005 (R.P. Out No Atten.) | +2 dBm | _____ dBm | |

Table 4-32. 8340A Test Record Card (13 of 27)

| SPECIFICATIONS TESTED Limits | Step | TEST Conditions | Lower Limit | Measured Value | Upper Limit |
|---|------|--------------------|----------------|-------------------|----------------|
| 4-13. Maximum Leveled Output Power and Power Accuracy (cont'd) | | | | | |
| Flatness | 9 | | | | |
| Band 0 Measurement | | | | | |
| Minimum Power Frequency | 13 | M2 Frequency | | _____ GHz | |
| Minimum Power Level | 14 | M2 Power Level | | _____ dBm | |
| Maximum Power Frequency | 15 | M1 Frequency | | _____ GHz | |
| Maximum Power Level | | M1 Power Level | | _____ dBm | |
| Band 1 Measurement | | | | | |
| Minimum Power Frequency | 13 | M2 Frequency | | _____ GHz | |
| Minimum Power Level | 14 | M2 Power Level | | _____ dBm | |
| Maximum Power Frequency | 15 | M1 Frequency | | _____ GHz | |
| Maximum Power Level | | M1 Power Level | | _____ dBm | |
| Band 2 Measurement | | | | | |
| Minimum Power Frequency | 13 | M2 Frequency | | _____ GHz | |
| Minimum Power Level | 14 | M2 Power Level | | _____ dBm | |
| Maximum Power Frequency | 15 | M1 Frequency | | _____ GHz | |
| Maximum Power Level | | M1 Power Level | | _____ dBm | |
| Band 3 Measurement | | | | | |
| Minimum Power Frequency | 13 | M2 Frequency | | _____ GHz | |
| Minimum Power Level | 14 | M2 Power Level | | _____ dBm | |
| Maximum Power Frequency | 15 | M1 Frequency | | _____ GHz | |
| Maximum Power Level | | M1 Power Level | | _____ dBm | |
| Band 4 Measurement | | | | | |
| Minimum Power Frequency | 13 | M2 Frequency | | _____ GHz | |
| Minimum Power Level | 14 | M2 Power Level | | _____ dBm | |
| Maximum Power Frequency | 15 | M1 Frequency | | _____ GHz | |
| Maximum Power Level | | M1 Power Level | | _____ dBm | |

Table 4-32. 8340A Test Record Card (14 of 27)

| SPECIFICATIONS TESTED Limits | Step | Specifications | Lower Limit | Measured Value | Upper Limit |
|---|------|--|-------------|----------------|-------------|
| 4-13. Maximum Leveled Output Power and Power Accuracy (cont'd) | | | | | |
| Flatness (Maximum minus Minimum Calculations) Band 0 Calculation | 18 | ≤ 1.0 dB (Standard) ≤ 1.2 dB (Option 004) ≤ 1.0 dB (Option 001) ≤ 1.2 dB (Option 005) | | _____ dB | |
| Band 1 Calculation | | ≤ 2.2 dB (Standard) ≤ 2.6 dB (Option 004) ≤ 1.8 dB (Option 001) ≤ 2.2 dB (Option 005) | | _____ dB | |
| Band 2 Calculation | | ≤ 2.2 dB (Standard) ≤ 2.6 dB (Option 004) ≤ 1.8 dB (Option 001) ≤ 2.2 dB (Option 005) | | _____ dB | |
| Band 3 Calculation | | ≤ 2.2 dB (Standard) ≤ 2.6 dB (Option 004) ≤ 1.8 dB (Option 001) ≤ 2.2 dB (Option 005) | | _____ dB | |
| Band 4 Calculation | | ≤ 3.2 dB (Standard) ≤ 3.6 dB (Option 004) ≤ 2.6 dB (Option 001) ≤ 3.0 dB (Option 005) | | _____ dB | |

Table 4-32. 8340A Test Record Card (15 of 27)

| SPECIFICATIONS TESTED Limits | Step | TEST Conditions | Lower Limit | Measured Value | Upper Limit |
|--|------|-----------------------------------|---|--|--|
| 4-14. External Leveling Leveling Voltage (dBv) +6 0 -10 -20 -30 -40 -50 -60 -66 | 3 | (Using Positive Crystal Detector) | 1.883 V 0.944 V 0.2983 V 0.0942 V 29.65 mV 9.24 mV 2.785 mV 0.744 mV 0.273 mV | _____ V _____ V _____ V _____ V _____ mV _____ mV _____ mV _____ mV _____ mV | 2.114 V 1.059 V 0.3352 V 0.1061 V 33.70 mV 10.79 mV 3.550 mV 1.259 mV 0.731 mV |

Table 4-32. 8340A Test Record Card (16 of 27)

| SPECIFICATIONS TESTED Limits | Step | TEST Conditions | Lower Limit | Measured Value | Upper Limit |
|--|------------|--|-------------|----------------|-------------|
| 4-15. Spurious Signals (10 MHz to 22 GHz) Frequency of Interest Selected | 4 6 | Refer to Table 4-15 for Specifications | | | |
| 4-16. Spurious Signals (22 to 26.5 GHz) Frequency of Interest Selected | 2 6 | Refer to Table 4-16 for Specifications | | | |

Table 4-32. 8340A Test Record Card (17 of 27)

| SPECIFICATIONS TESTED Limits | Step | TEST Conditions | Lower Limit | Measured Value | Upper Limit |
|---|------|-----------------|-------------|---|---|
| 4-17. Single Sideband Phase Noise from Steps 11 through 38 (Using Tables 4-18, 4-19, and 4-21) 2.202 GHz Offset = 30 Hz 100 Hz 1 kHz 10 kHz 100 kHz 6.902 GHz Offset = 30 Hz 100 Hz 1 kHz 10 kHz 100 kHz 13.402 GHz Offset = 30 Hz 100 Hz 1 kHz 10 kHz 100 kHz 19.502 GHz Offset = 30 Hz 100 Hz 1 kHz 10 kHz 100 kHz 26.032 GHz Offset = 30 Hz 100 Hz 1 kHz 10 kHz 100 kHz | 38 | | | _____ dBc _____ dBc _____ dBc _____ dBc _____ dBc _____ dBc _____ dBc _____ dBc _____ dBc _____ dBc _____ dBc _____ dBc _____ dBc _____ dBc _____ dBc _____ dBc _____ dBc _____ dBc _____ dBc _____ dBc _____ dBc _____ dBc _____ dBc _____ dBc _____ dBc | <- 64 dBc <- 70 dBc <- 78 dBc <- 86 dBc <-107 dBc <- 64 dBc <- 70 dBc <- 78 dBc <- 86 dBc <-107 dBc <- 58 dBc <- 64 dBc <- 72 dBc <- 80 dBc <-101 dBc <- 54 dBc <- 60 dBc <- 68 dBc <- 76 dBc <- 97 dBc <- 52 dBc <- 58 dBc <- 66 dBc <- 74 dBc <- 95 dBc |
| Option 007 - Relaxed Phase Noise Specifications 2.202 GHz Offset = 100 Hz 1 kHz 10 kHz 100 kHz 6.902 GHz Offset = 100 Hz 1 kHz 10 kHz 100 kHz 13.402 GHz Offset = 100 Hz 1 kHz 10 kHz 100 kHz | | | | _____ dBc _____ dBc _____ dBc _____ dBc _____ dBc _____ dBc _____ dBc _____ dBc _____ dBc _____ dBc _____ dBc _____ dBc | <-67 dBc <-75 dBc <-83 dBc <-107 dBc <- 67 dBc <-75 dBc <- 83 dBc <-107 dBc <-61 dBc <-69 dBc <-77 dBc <-101 dBc |

Table 4.32. 8340A Test Record Card (18 of 27)

| SPECIFICATIONS TESTED Limits | Step | TEST Conditions | Lower Limit | Measured Value | Upper Limit |
|---|---|---|--|--|--|
| Option 007 - Relaxed Phase Noise Specifications (Cont'd) 19.502 GHz Offset = 100 kHz 1 kHz 10 kHz 100 kHz 26.032 GHz Offset = 100 Hz 1 Hz 10 kHz 100 kHz | | | | _____ dBc _____ dBc _____ dBc _____ dBc _____ dBc _____ dBc _____ dBc _____ dBc | <- 57 dBc <- 65 dBc <- 73 dBc <- 97 dBc <- 55 dBc <- 63 dBc <- 71 dBc <- 95 dBc |
| 4-18. Power Sweep 1 GHz Start Level End Level Power Sweep Range 5 GHz Start Level End Level Power Sweep Range 10 GHz Start Level End Level Power Sweep Range 15 GHz Start Level End Level Power Sweep Range 26 GHz Start Level End Level Power Sweep Range | 5 6 7 5 6 7 5 6 7 5 6 7 5 6 7 | Must be ≥ 20 dB difference Must be ≥ 20 dB difference Must be ≥ 20 dB difference Must be ≥ 20 dB difference Must be ≥ 20 dB difference | 20 dB 20 dB 20 dB 20 dB | _____ dBm _____ dBm _____ dB _____ dBm _____ dBm _____ dB _____ dBm _____ dBm _____ dB _____ dBm _____ dBm _____ dB | |

Table 4-32. 8340A Test Record Card (19 of 27)

| SPECIFICATIONS TESTED Limits | Step | TEST Conditions | Lower Limit | Measured Value | Upper Limit |
|--|------|--|-------------|----------------|-------------|
| 4-19. Pulse Modulation ON/OFF Ratio | | | | | |
| 1 GHz | 4 | ΔAmplitude must be > 80 dB | 80 dB | _____ dB | |
| 3 GHz | | | 80 dB | _____ dB | |
| 9 GHz | | | 80 dB | _____ dB | |
| 15 GHz | | | 80 dB | _____ dB | |
| 22 GHz | | | 80 dB | _____ dB | |
| 4-20. Pulse Modulation Rise and Fall Time | | | | | |
| 1 GHz | | Rise Times: 90% point should be <25 nanoseconds from 10% point | | _____ nsec | 25 nsec |
| Rise Time | 6 | | | | |
| Fall Time | 8 | | | _____ nsec | 25 nsec |
| 3 GHz | | Fall Times: 10% point should be <25 nanoseconds from 90% point | | _____ nsec | 25 nsec |
| Rise Time | 6 | | | | |
| Fall Time | 8 | | | _____ nsec | 25 nsec |
| 9 GHz | | | | _____ nsec | 25 nsec |
| Rise Time | 6 | | | | |
| Fall Time | 8 | | | _____ nsec | 25nsec |
| 15 GHz | | | | _____ nsec | 25 nsec |
| Rise Time | 6 | | | | |
| Fall Time | 8 | | | _____ nsec | 25 nsec |
| 22 GHz | | | | _____ nsec | 25 nsec |
| Rise Time | 6 | | | | |
| Fall Time | 8 | | | _____ nsec | 25 nsec |

Table 4-32. 8340A Test Record Card (20 of 27)

| SPECIFICATIONS TESTED Limits | Step | TEST Conditions | Lower Limit | Measured Value | Upper Limit |
|--|------|--------------------------------------|----------------|-------------------|----------------|
| 4-21. Pulse Modulation Accuracy | | | | | |
| 8340A CW Freq. = 1 GHz PRF = 100 kHz | | | | | |
| Pulse Width = 100 nsec | 6 | ENTRY DISPLAY Power Level | | _____ dBm | |
| | 7 | ENTRY DISPLAY Power Level | | _____ dBm | |
| | 8 | Δ Power between steps 6 and 7 | >-0.3 dB | _____ dB | <+3 dB |
| Pulse Width = 200 nsec | 6 | ENTRY DISPLAY Power Level | | _____ dBm | |
| | 7 | ENTRY DISPLAY Power Level | | _____ dBm | |
| | 8 | Δ Power between steps 6 and 7 | >-0.3 dB | _____ dB | <+1.5 dB |
| Pulse Width = 500 nsec | 6 | ENTRY DISPLAY Power Level | | _____ dBm | |
| | 7 | ENTRY DISPLAY Power Level | | _____ dBm | |
| | 8 | Δ Power between steps 6 and 7 | >-0.3 dB | _____ dB | <+0.3 dB |
| Pulse Width = 1000 nsec | 6 | ENTRY DISPLAY Power Level | | _____ dBm | |
| | 7 | ENTRY DISPLAY Power Level | | _____ dBm | |
| | 8 | Δ Power between steps 6 and 7 | >-0.3 dB | _____ dB | <+0.3 dB |
| Pulse Repetition Freq. Range 8340A CW Freq. = 1 GHz | 10 | | | | |
| Minimum PRF PRF = 100 Hz PW = 1 microsecond | 6 | ENTRY DISPLAY Power Level | | _____ dBm | |
| | 7 | ENTRY DISPLAY Power Level | | _____ dBm | |
| | 8 | Δ Power between steps 6 and 7 | >-0.3 dB | _____ dB | <+0.3 dB |
| Maximum PRF PRF = 5 MHz PW = 100 nanoseconds | 6 | ENTRY DISPLAY Power Level | | _____ dBm | |
| | 7 | ENTRY DISPLAY Power Level | | _____ dBm | |
| | 8 | Δ Power between steps 6 and 7 | >-0.3 dB | _____ dB | <+3 dB |
| 8340A CW Freq. = 3 GHz PRF = 100 kHz | | | | | |
| Pulse Width = 100 nsec | 6 | ENTRY DISPLAY Power Level | | _____ dBm | |
| | 7 | ENTRY DISPLAY Power Level | | _____ dBm | |
| | 8 | Δ Power between steps 6 and 7 | >-0.3 dB | _____ dB | <+1.5 dB |
| Pulse Width = 200 nsec | 6 | ENTRY DISPLAY Power Level | | _____ dBm | |
| | 7 | ENTRY DISPLAY Power Level | | _____ dBm | |
| | 8 | Δ Power between steps 6 and 7 | >-0.3 dB | _____ dB | <+0.3 dB |
| Pulse Width = 500 nsec | 6 | ENTRY DISPLAY Power Level | | _____ dBm | |
| | 7 | ENTRY DISPLAY Power Level | | _____ dBm | |
| | 8 | Δ Power between steps 6 and 7 | >-0.3 dB | _____ dB | <+0.3 dB |
| Pulse Width = 1000 nsec | 6 | ENTRY DISPLAY Power Level | | _____ dBm | |
| | 7 | ENTRY DISPLAY Power Level | | _____ dBm | |
| | 8 | Δ Power between steps 6 and 7 | >-0.3 dB | _____ dB | <+0.3 dB |

Table 4-32. 8340A Test Record Card (21 of 27)

| SPECIFICATIONS TESTED Limits | Step | TEST Conditions | Lower Limit | Measured Value | Upper Limit |
|--|------|-------------------------------|-------------|----------------|-------------|
| 4-21. Pulse Modulation Accuracy, (cont'd) | | | | | |
| Pulse Repetition Freq. Range 8340A CW Freq. = 3 GHz | 10 | | | | |
| Minimum PRF PRF = 100 Hz PW = 1 microsecond | 6 | ENTRY DISPLAY Power Level | | _____ dBm | |
| | 7 | ENTRY DISPLAY Power Level | | _____ dBm | |
| | 8 | Δ Power between steps 6 and 7 | >-0.3 dB | _____ dB | <+0.3 dB |
| Maximum PRF PRF = 5 MHz PW = 100 nanoseconds | 6 | ENTRY DISPLAY Power Level | | _____ dBm | |
| | 7 | ENTRY DISPLAY Power Level | | _____ dBm | |
| | 8 | Δ Power between steps 6 and 7 | >-0.3 dB | _____ dB | <+1.5 dB |
| 8340A CW Freq. = 9 GHz PRF = 100 kHz | | | | | |
| Pulse Width = 100 nsec | 6 | ENTRY DISPLAY Power Level | | _____ dBm | |
| | 7 | ENTRY DISPLAY Power Level | | _____ dBm | |
| | 8 | Δ Power between steps 6 and 7 | >-0.3dB | _____ dB | <+1.5 dB |
| Pulse Width = 200 nsec | 6 | ENTRY DISPLAY Power Level | | _____ dBm | |
| | 7 | ENTRY DISPLAY Power Level | | _____ dBm | |
| | 8 | Δ Power between steps 6 and 7 | >-0.3 dB | _____ dB | <+0.3 dB |
| Pulse Width = 500 nsec | 6 | ENTRY DISPLAY Power Level | | _____ dBm | |
| | 7 | ENTRY DISPLAY Power Level | | _____ dBm | |
| | 8 | Δ Power between steps 6 and 7 | >-0.3 dB | _____ dB | <+0.3 dB |
| Pulse Width = 1000 nsec | 6 | ENTRY DISPLAY Power Level | | _____ dBm | |
| | 7 | ENTRY DISPLAY Power Level | | _____ dBm | |
| | 8 | Δ Power between steps 6 and 7 | >-0.3 dB | _____ dB | <+0.3 dB |
| Pulse Repetition Freq. Range 8340A CW Freq. = 9 GHz | 10 | | | | |
| Minimum PRF PRF = 100 Hz PW = 1 microsecond | 6 | ENTRY DISPLAY Power Level | | _____ dBm | |
| | 7 | ENTRY DISPLAY Power Level | | _____ dBm | |
| | 8 | Δ Power between steps 6 and 7 | >-0.3 dB | _____ dB | <+0.3 dB |
| Maximum PRF PRF = 5 MHz PW = 100 nanoseconds | 6 | ENTRY DISPLAY Power Level | | _____ dBm | |
| | 7 | ENTRY DISPLAY Power Level | | _____ dBm | |
| | 8 | Δ Power between steps 6 and 7 | >-0.3 dB | _____ dB | <+1.5 dB |

Table 4-32. 8340A Test Record Card (22 of 27)

| SPECIFICATIONS TESTED Limits | Step | TEST Conditions | Lower Limit | Measured Value | Upper Limit |
|--|-------------------------------|-------------------------------|-------------|----------------|-------------|
| 4-21. Pulse Modulation Accuracy, (cont'd) 8340A CW Freq. = 15 GHz PRF = 100 kHz Pulse Width = 100 nsec Pulse Width = 200 nsec Pulse Width = 500 nsec Pulse Width = 1000 nsec Pulse Repetition Freq. Range 8340A CW Freq. = 15 GHz Minimum PRF PRF = 100 Hz PW = 1 microsecond Maximum PRF PRF = 5 MHz PW = 100 nanoseconds 8340A CW Freq. = 22 GHz PRF = 100 kHz Pulse Width = 100 nsec Pulse Width = 200 nsec Pulse Width = 500 nsec Pulse Width = 1000 nsec | | | | | |
| | 6 | ENTRY DISPLAY Power Level | | _____ dBm | |
| | 7 | ENTRY DISPLAY Power Level | | _____ dBm | |
| | 8 | Δ Power between steps 6 and 7 | > -0.3 dB | _____ dB | < +1.5 dB |
| | 6 | ENTRY DISPLAY Power Level | | _____ dBm | |
| | 7 | ENTRY DISPLAY Power Level | | _____ dBm | |
| | 8 | Δ Power between steps 6 and 7 | > -0.3 dB | _____ dB | < +0.3 dB |
| | 6 | ENTRY DISPLAY Power Level | | _____ dBm | |
| | 7 | ENTRY DISPLAY Power Level | | _____ dBm | |
| | 8 | Δ Power between steps 6 and 7 | > -0.3 dB | _____ dB | < +0.3 dB |
| | 6 | ENTRY DISPLAY Power Level | | _____ dBm | |
| | 7 | ENTRY DISPLAY Power Level | | _____ dBm | |
| | 8 | Δ Power between steps 6 and 7 | > -0.3 dB | _____ dB | < +0.3 dB |
| | 10 | | | | |
| | 6 | ENTRY DISPLAY Power Level | | _____ dBm | |
| | 7 | ENTRY DISPLAY Power Level | | _____ dBm | |
| | 8 | Δ Power between steps 6 and 7 | > -0.3 dB | _____ dB | < +0.3 dB |
| | 6 | ENTRY DISPLAY Power Level | | _____ dBm | |
| | 7 | ENTRY DISPLAY Power Level | | _____ dBm | |
| | 8 | Δ Power between steps 6 and 7 | > -0.3 dB | _____ dB | < +1.5 dB |
| | 6 | ENTRY DISPLAY Power Level | | _____ dBm | |
| | 7 | ENTRY DISPLAY Power Level | | _____ dBm | |
| | 8 | Δ Power between steps 6 and 7 | > -0.3 dB | _____ dB | < +1.5 dB |
| | 6 | ENTRY DISPLAY Power Level | | _____ dBm | |
| 7 | ENTRY DISPLAY Power Level | | _____ dBm | | |
| 8 | Δ Power between steps 6 and 7 | > -0.3 dB | _____ dB | < +0.3 dB | |
| 6 | ENTRY DISPLAY Power Level | | _____ dBm | | |
| 7 | ENTRY DISPLAY Power Level | | _____ dBm | | |
| 8 | Δ Power between steps 6 and 7 | > -0.3 dB | _____ dB | < +0.3 dB | |
| 6 | ENTRY DISPLAY Power Level | | _____ dBm | | |
| 7 | ENTRY DISPLAY Power Level | | _____ dBm | | |
| 8 | Δ Power between steps 6 and 7 | > -0.3 dB | _____ dB | < +0.3 dB | |

Table 4-32. 8340A Test Record Card (23 of 27)

| SPECIFICATIONS TESTED Limits | Step | TEST Conditions | Lower Limit | Measured Value | Upper Limit |
|--|------|--------------------------------------|-------------|----------------|-------------|
| 4-21. Pulse Modulation Accuracy, (cont'd) Pulse Repetition Freq. Range 8340A CW Freq. = 22 GHz Minimum PRF PRF = 100 Hz PW = 1 microsecond Maximum PRF PRF = 5 MHz PW = 100 nanoseconds | 10 | | | | |
| | 6 | ENTRY DISPLAY Power Level | | _____ dBm | |
| | 7 | ENTRY DISPLAY Power Level | | _____ dBm | |
| | 8 | Δ Power between steps 6 and 7 | >-0.3 dB | _____ dB | <+0.3 dB |
| | 6 | ENTRY DISPLAY Power Level | | _____ dBm | |
| | 7 | ENTRY DISPLAY Power Level | | _____ dBm | |
| | 8 | Δ Power between steps 6 and 7 | >-0.3 dB | _____ dB | <+1.5 dB |

Table 4-32. 8340A Test Record Card (24 of 27)

| SPECIFICATIONS TESTED Limits | Step | TEST Conditions | Lower Limit | Measured Value | Upper Limit |
|--|------|---------------------------|----------------|-------------------|----------------|
| 4-22. Pulse Modulation Video Feedthrough | | | | | |
| 8340A CW Freq. = 0.5 GHz Power Level = +8 dBm 0 dBm -10 dBm | 7 | Oscilloscope peak voltage | | _____ mV | <12 mV |
| 8340A CW Freq. = 1 GHz Power Level = +8 dBm 0 dBm -10 dBm | 7 | | | _____ mV | <5 mV |
| 8340A CW Freq. = 1.5 GHz Power Level = +8 dBm 0 dBm -10 dBm | 7 | | | _____ mV | <1.6 mV |
| 8340A CW Freq. = 2 GHz Power Level = +8 dBm 0 dBm -10 dBm | 7 | | | _____ mV | <12 mV |
| 8340A CW Freq. = >2.3 GHz Power Level = -10 dBm (Any Frequency Selected) | 10 | | | _____ mV | <0.2 mV |

Table 4-32. 8340A Test Record Card (25 of 27)

| SPECIFICATIONS TESTED Limits | Step | TEST Conditions | Lower Limit | Measured Value | Upper Limit |
|--|------|--|-------------|------------------------|-------------|
| 4-23. Amplitude Modulation | | | | | |
| AM Sensitivity | | | | | |
| 8340A Freq. = 1.5 GHz Power = -5 dBm | 2 | | | | |
| +30% Modulation | 4 | Power Meter Indication | | _____ dB | |
| -30% Modulation | 5 | Power Meter Change | >2.18 dB | _____ dB | <2.38 dB |
| | 6 | Power Meter Change | >2.91 dB | _____ dB | <3.29 dB |
| 8340A Freq. = 1.5 GHz Power = +5 dBm | 7 | | | | |
| +30% Modulation | 4 | Power Meter Indication | | _____ dB | |
| -30% Modulation | 5 | Power Meter Change | >2.18 dB | _____ dB | <2.38 dB |
| | 6 | Power Meter Change | >2.91 dB | _____ dB | <3.29 dB |
| 8340A Freq. = 4.5 GHz Power = -5 dBm | 8 | | | | |
| +30% Modulation | 4 | Power Meter Indication | | _____ dB | |
| -30% Modulation | 5 | Power Meter Change | >2.18 dB | _____ dB | <2.38 dB |
| | 6 | Power Meter Change | >2.91 dB | _____ dB | <3.29 dB |
| 8340A Freq. = 4.5 GHz Power = +5 dBm | 8 | | | | |
| +30% Modulation | 4 | Power Meter Indication | >2.18 dB | _____ dB | |
| -30% Modulation | 5 | Power Meter Change | >2.91 dB | _____ dB | <2.38 dB |
| | 6 | Power Meter Change | | _____ dB | <3.29 dB |
| 8340A Freq. = 1.5 GHz | | | | | |
| AM Frequency Response | 11 | Note DVM Indication | | _____ V _{rms} | |
| Funct. Gen. = 1 kHz | 12 | Flatness (read on Modulation Analyzer) | | _____ dB | ≤±0.2 dB |
| 100 Hz | 13 | | | _____ dB | ≤±0.2 dB |
| 200 Hz | | | | _____ dB | ≤±0.2 dB |
| 500 Hz | | | | _____ dB | ≤±0.2 dB |
| 2 kHz | | | | _____ dB | ≤±0.2 dB |
| 5 kHz | | | | _____ dB | ≤±0.2 dB |
| 10 kHz | | | | _____ dB | ≤±0.2 dB |
| AM Bandwidth | 14 | Modulation Analyzer Indication | ≥-3 dB | _____ dB | |
| Funct. Gen. = 100 kHz | | | | | |
| Adjust output level to that noted in Step 11 | | | | | |
| AM Depth | 15 | Maximum Modulation Depth | >90% | _____ % | |
| Funct. Gen. = 1kHz | | | | | |

Table 4-32. 8340A Test Record Card (26 of 27)

| SPECIFICATIONS TESTED Limits | Step | TEST Conditions | Lower Limit | Measured Value | Upper Limit |
|---|------|------------------------------|----------------|-------------------|-------------------|
| 4-23. Amplitude Modulation (cont'd) | | | | | |
| 8340A Freq. = 3 GHz | | | | | |
| AM Frequency Response | 11 | Note DVM Indication | | _____ Vrms | |
| Funct. Gen. = 1 kHz | 12 | Flatness (read on Modulation | | _____ dB | $\leq \pm 0.2$ dB |
| 100 Hz | 13 | Analyzer) | | _____ dB | $\leq \pm 0.2$ dB |
| 200 Hz | | | | _____ dB | $\leq \pm 0.2$ dB |
| 500 Hz | | | | _____ dB | $\leq \pm 0.2$ dB |
| 2 kHz | | | | _____ dB | $\leq \pm 0.2$ dB |
| 5 kHz | | | | _____ dB | $\leq \pm 0.2$ dB |
| 10 kHz | | | | _____ dB | $\leq \pm 0.2$ dB |
| AM Bandwidth | 14 | Modulation Analyzer | ≥ -3 dB | _____ dB | |
| Funct. Gen. = 100 kHz | | Indication | | | |
| Adjust output level to that noted in Step 11 | | | | | |
| AM Depth | 15 | Maximum Modulation Depth | $>90\%$ | _____ % | |
| Funct. Gen. = 1 kHz | | | | | |
| 8340A Freq. = 9 GHz | | | | | |
| AM Frequency Response | 11 | Note DVM Indication | | _____ Vrms | |
| Funct. Gen. = 1 kHz | 12 | Flatness (read on Modulation | | _____ dB | $\leq \pm 0.2$ dB |
| 100 Hz | 13 | Analyzer) | | _____ dB | $\leq \pm 0.2$ dB |
| 200 Hz | | | | _____ dB | $\leq \pm 0.2$ dB |
| 500 Hz | | | | _____ dB | $\leq \pm 0.2$ dB |
| 2 kHz | | | | _____ dB | $\leq \pm 0.2$ dB |
| 5 kHz | | | | _____ dB | $\leq \pm 0.2$ dB |
| 10 kHz | | | | _____ dB | $\leq \pm 0.2$ dB |
| AM Bandwidth | 14 | Modulation Analyzer | ≥ -3 dB | _____ dB | |
| Funct. Gen. = 100 kHz | | Indication | | | |
| Adjust output level to that noted in Step 11 | | | | | |
| AM Depth | 15 | Maximum Modulation Depth | $>90\%$ | _____ % | |
| Funct. Gen. = 1 kHz | | | | | |
| 8340A Freq. = 15 GHz | | | | | |
| AM Frequency Response | 11 | Note DVM Indication | | _____ Vrms | |
| Funct. Gen. = 1 kHz | 12 | Flatness (read on Modulation | | _____ dB | $\leq \pm 0.2$ dB |
| 100 Hz | 13 | Analyzer) | | _____ dB | $\leq \pm 0.2$ dB |
| 200 Hz | | | | _____ dB | $\leq \pm 0.2$ dB |
| 500 Hz | | | | _____ dB | $\leq \pm 0.2$ dB |
| 2 kHz | | | | _____ dB | $\leq \pm 0.2$ dB |
| 5 kHz | | | | _____ dB | $\leq \pm 0.2$ dB |
| 10 kHz | | | | _____ dB | $\leq \pm 0.2$ dB |
| AM Bandwidth | 14 | Modulation Analyzer | ≥ -3 dB | _____ dB | |
| Funct. Gen. = 100 kHz | | Indication | | | |
| Adjust output level to that noted in Step 11 | | | | | |
| AM Depth | 15 | Maximum Modulation Depth | $>90\%$ | _____ % | |
| Funct. Gen. = 1 kHz | | | | | |

Table 4-32. 8340A Test Record Card (27 of 27)

| SPECIFICATIONS TESTED Limits | Step | TEST Conditions | Lower Limit | Measured Value | Upper Limit |
|--|------|------------------------------|----------------|------------------------|----------------|
| 4-23. Amplitude Modulation (cont'd) | | | | | |
| 8340A Freq. = 22 GHz | | | | | |
| AM Frequency Response | 11 | Note DVM Indication | | _____ V _{rms} | |
| Funct. Gen. = 1 kHz | 12 | Flatness (read on Modulation | | _____ dB | ≤±0.2 dB |
| 100 Hz | 13 | Analyzer) | | _____ dB | ≤±0.2 dB |
| 200 Hz | | | | _____ dB | ≤±0.2 dB |
| 500 Hz | | | | _____ dB | ≤±0.2 dB |
| 2 kHz | | | | _____ dB | ≤±0.2 dB |
| 5 kHz | | | | _____ dB | ≤±0.2 dB |
| 10 kHz | | | | _____ dB | ≤±0.2 dB |
| AM Bandwidth | 14 | Modulation Analyzer | ≥-3 dB | _____ dB | |
| Funct. Gen. = 100 kHz | | Indication | | | |
| Adjust output level to that | | | | | |
| noted in Step 11 | | | | | |
| AM Depth | 15 | Maximum Modulation Depth | >90 % | _____ % | |
| Funct. Gen. = 1 kHz | | | | | |

**APPENDIX A
IN CASE OF DIFFICULTY: ERROR ANNUNCIATORS**

This section explains what to do when one of the HP 8340A front panel annunciators comes on. It tells you how to tell the difference between a procedural error and actual instrument failure.

Detailed service information and an Overall Instrument Trouble-shooting Guide is available in the Introduction to Section VIII (Service) of the HP 8340A manual, volume 3 of the 4-volume HP 8340A manual set.

Figure A-1, on the next page, shows where the front and rear panel annunciators are located.

Front View

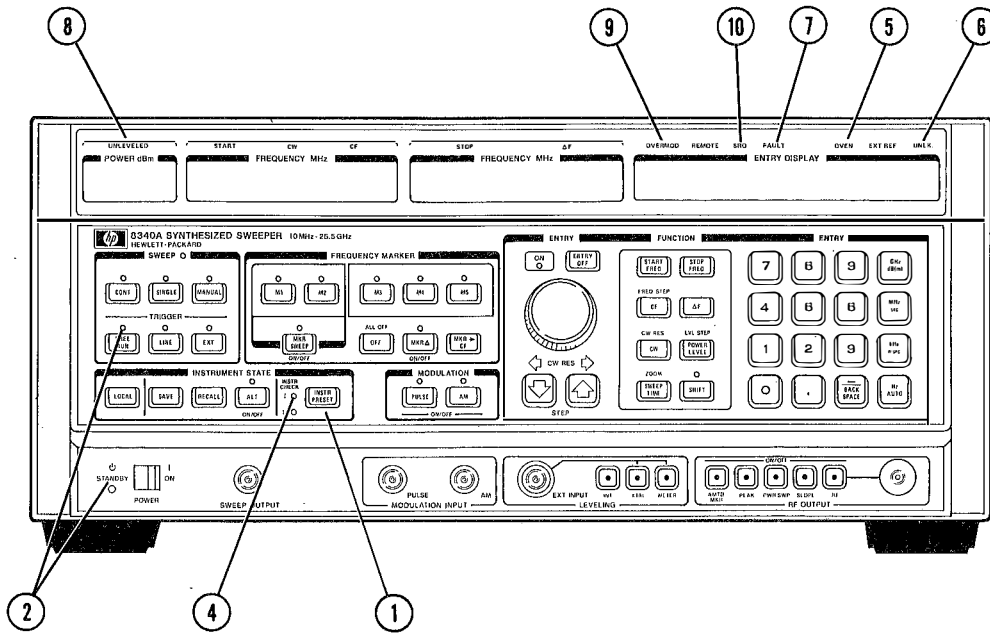

Rear View

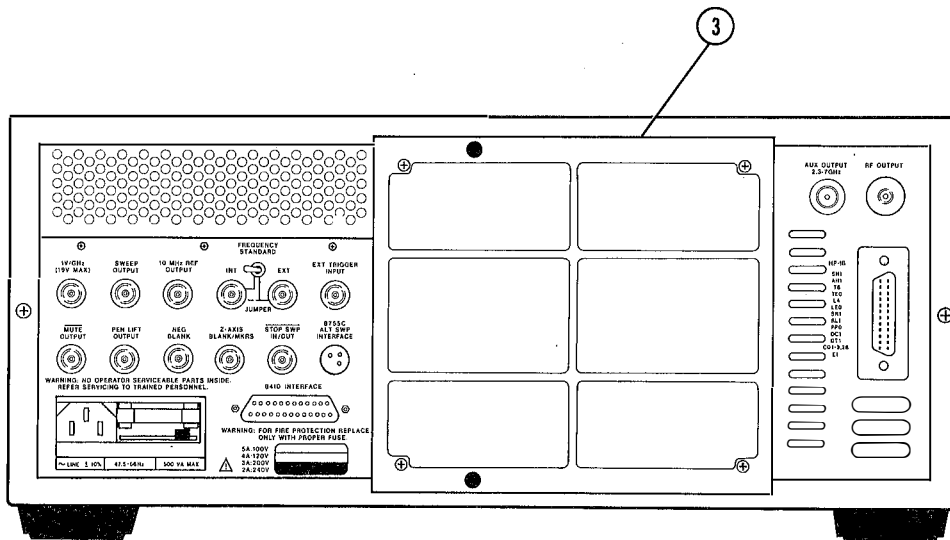

Figure A-1. HP 8340A Error Annunciators

1. INSTRUMENT PRESET CONDITIONS [INSTR PRESET]

Press [INSTR PRESET] and check that the following settings exist. If any instrument condition is not as shown below, the instrument requires service.

POWER dBm display = 0.0

Factory setting, determined by cal constant #56.

A different power level can be set by changing calibration constant #56. See step 7 of this appendix: Calibration Constant Access Procedure.

FREQUENCY MHz display = 10.000000
START annunciator lit

FREQUENCY MHz display = 26.500000
STOP annunciator lit

ENTRY display = Blank (off)

SWEEP block = Green LED flashing
CONT LED on
FREE RUN LED on

FREQUENCY MARKER block = All LED's off

INSTRUMENT STATE block = All LED's off

MODULATION block = All LED's off

ENTRY block = All LED's off

LEVELING block = INT LED on

RF OUTPUT block = RF LED on

The RF output should be a swept 10 MHz to 26.5 GHz signal, leveled at 0 dBm.

EXT REF annunciator = off.

If the rear panel **INT** or **EXT REFERENCE** switch is in the **EXT** position, the **EXT REF** annunciator above the **ENTRY DISPLAY** will be on.

2. INCORRECT FRONT PANEL STATES after [INSTR PRESET]

All LED's Off.

FAN IS OPERATING - If all annunciators and LED's are off (but the instrument's fan is operating), check the thermal shutdown switch (A62SI) in the HP 8340A power supply. If the switch has engaged, make sure the fan is supplying proper airflow to

the interior of the instrument. Make sure the fan filter is not blocked by dust accumulation, a piece of paper, etc. If the instrument's airflow is good, suspect a power supply failure.

FAN IS NOT OPERATING, LED'S COME ON AT POWER ON, THEN GO OUT LATER - Refer to the FAN section, below.

FAN IS NOT OPERATING, LED'S OFF AT POWER ON - If all instrument LED's are off and the fan is not operating, suspect a problem in the instrument causing complete loss of ac mains, i.e. transformer, wiring, or line filter module related problems. Check the line filter module voltage select card (Refer to Section II, Installation).

SOME LED'S OFF. If some LED's that should be on are off, the instrument's front panel section is probably the cause.

ALL LED'S ON. If all of the LED's and annunciators are on, instrument processor, memory, or power supply is probably the cause.

CHARACTER MARCH. If the four display windows have strings of characters marching across them, the instrument processor or memory is probably the cause.

3. FAN

FAN DOES NOT TURN ON. When the **POWER** switch is turned **ON**, the instrument fan should start running. If it does not, the fan, power supply, or K1 Relay (inside the instrument near the rear panel) is probably the cause.

If the instrument has run for some time with the fan not running, the interior temperature may have risen to the point that the A62S1 thermal switch has turned the instrument off. If so, all front panel LED's will have gone off. The switch will reset itself when the instrument cools down.

FAN DOES NOT TURN OFF. When the instrument is in the **STANDBY** mode, the fan should not be running. If it is, the Fan Relay (K1) may be stuck, or it the +22V supply has failed. The fan relay solenoid is **energized** when the instrument is in the **STANDBY** mode, turning the fan **off**. If the power to the relay solenoid fails (+22V supply), the solenoid will **de-energize**, turning the fan **on**.

4. INSTR CHECK LED'S REMAIN ON

INSTR CHECK LED'S I and II show the results of the instrument Self-Test sequence. This test sequence is carried out every time the **POWER** switch is turned on or when **[INSTR PRESET]** is pressed. These LED's come on immediately upon initiating Self-Test. Both LED's should be off after about 1 second.

INSTR CHECK LED I REMAINS ON. Indicates that there is a Processor board-related problem. Suspect the microprocessor, memory, or Peripheral Interface Timer.

INSTR CHECK LED II REMAINS ON. Indicates that there is a Marker RAM, I/O Data bus, or I/O Address bus-related problem. The Marker RAM is located on the A57 Marker/Bandcross board.

5. OVEN ANNUNCIATOR

The front panel **OVEN** light is used to indicate the status of the internal frequency standard. When the **OVEN** annunciator is on, the frequency is more than 100 Hz from 10 MHz.

If the internal 10 MHz standard is being used, this will cause the frequency of the RF output to be inaccurate. The **OVEN** annunciator should go out within one half hour after the instrument is connected to ac mains. If the **OVEN** annunciator stays on, the instrument requires service.

If the instrument is using an external 10 MHz standard, this indication will have no effect on instrument performance.

6. UNLK ANNUNCIATOR

The **UNLK** light is used to indicate that that one or more of the six instrument phase lock loops is unlocked. Press **[SHIFT] [EXT]**. The **ENTRY DISPLAY** will show the following:

OSC: REF M/N HET YO N2 N1

The name of the phase lock loop that is unlocked will be flashing. The different loops are listed below along with information about what to do if one of them is unlocked.

REF - If **REF** (reference loop) is flashing, inspect the rear panel, one of two conditions should exist:

A. If the instrument is in internal 10 MHz mode:

Make sure the **INT STANDARD** BNC and the **EXT STANDARD** BNC are connected together with a jumper cable. Ensure that the rear panel **REFERENCE** switch is in the **INT** position. If this is the case and **REF** is flashing, the instrument requires service. Suspect a problem in the Reference Loop.

B. If the instrument is in external 10 MHz mode:

An external 10 MHz standard should be connected to the **EXT STANDARD** BNC with the rear panel **REFERENCE** switch in the **EXT** position. If this is the case and **REF** is flashing, connect the instrument as described in step A, above. Press **[SHIFT] [EXT]**.

If REF keeps flashing, the instrument requires service. Suspect a problem in the Reference Loop.

If REF stops flashing the problem is being caused by the external 10 MHz Reference Standard.

If any of the following indicators are flashing, the instrument requires service.

M/N - Suspect the M/N Loop.

HET - Suspect a problem in the 3.7 GHz Oscillator in the RF section.

YO - Suspect the YO loop.

N1 - Suspect a problem in the PLL1 or PLL3 Loops in the 20-30 Loops.

N2 - Suspect a problem in the PLL2 loop in the 20-30 Loops.

7. FAULT ANNUNCIATOR

The **FAULT** light is used to monitor the status of 5 different internal functions. These functions are described below. If the **FAULT** light is on, press **[SHIFT] [MANUAL]**. The **ENTRY DISPLAY** will show the following:

FAULT: CAL KICK ADC PEAK TRK

The name of the function that has a problem will be flashing.

CAL - This refers to the calibration constants stored in memory (on the A60 Processor board). The calibration constants are checked only when an **[INSTR PRESET]** is done. If **CAL** is flashing the instrument has resorted to default calibration constant data. The major effect of this condition will be RF power output flatness and accuracy degradation. To remedy this situation, the factory-determined calibration constants must be re-entered into the instrument's memory. Remove the top cover of the instrument. Get the print-out of the calibration constants from the plastic jacket located on the left-hand side of the instrument. Replace the instrument's top cover. The following procedure must be performed to enter the calibration constants back into memory. When this procedure is complete, place the calibration constant print-out back into the instrument.

CAUTION

The following procedure affects data required for optimum performance of the instrument. Care should be taken when accessing or changing calibration data.

Calibration Constant Access Procedure

1. Press **[SHIFT] [GHz] [1] [Hz]**
[SHIFT] [MHz] [1] [2] [Hz]
[SHIFT] [KHz] [2] [2] [Hz]

The value of calibration Constant #1 will be displayed in the **ENTRY DISPLAY**.

2. Compare the value on the **ENTRY DISPLAY** with the value listed in the print-out. If the values do not match, enter the value from the print-out via the **DATA ENTRY** keyboard and then press **[Hz]**. Press the up **STEP** key to view the next calibration constant.
3. Repeat step 2 until all the instrument calibration constants are the same as those shown on the print-out.
4. Store the entered calibration constants into protected memory by pressing the following keys:

[SHIFT] [MHz] [1] [4] [Hz]
 [SHIFT] [MHz] [1] [9] [4] [6] [Hz]

The "CALIBRATION STORED" message will appear in the **ENTRY DISPLAY**.

Press [INSTR PRESET], the **FAULT** indicator should be off. If it is still on, suspect a problem with the instrument's memory.

KICK - This refers to the kick pulses used to reset the YO (YIG Oscillator) and SYTM (Switched YIG-Tuned Multiplier). Suspect a problem in the A54 YIG Oscillator Pretune assembly or the A28 SYTM Driver board.

ADC - This refers to a check performed on the ADC (analog to digital converter) circuits on the A27 Level Control board. This check is done at [INSTR PRESET] or power on. ADC indicates that the **POWER dBm** display may indicate a different power than the instrument is actually producing. Also, an ADC failure will not allow the Peak ([PEAK]) and Auto Tracking ([SHIFT] [PEAK]) functions to operate properly. If this annunciator is on, suspect a problem on the A27 Level Control board.

PEAK - This refers to an instrument function that peaks the RF output power at a **CW frequency** by fine tuning the SYTM (the SYTM is tuned to the YO frequency). This fault can only come on if the [PEAK] button is pushed. If **PEAK** is flashing, something is wrong with the circuitry that peaks the SYTM. **PEAK** indicates that the instrument is not able to optimize its output power. This is an instrument failure which requires service to correct. However, the optimum power may not be adversely affected and may still be acceptable to the operator.

TRK - This refers to an instrument function that peaks the RF output power while the instrument is **sweeping**. This fault can only occur if [SHIFT] [PEAK] has been pushed. The **TRK** light indicates the same things as if **PEAK** were flashing.

8. UNLEVELED ANNUNCIATOR

The **UNLEVELED** light is used to indicate the status of the RF output power. If the **UNLEVELED** light is off, the output power is leveled and if the light is on, the power is unleveled.

- A. Make sure that the correct leveling mode is selected. If internal leveling is desired, the **INT** light should be on. If external leveling is desired, the **XTAL** light should be on. If power meter leveling is desired, the **METER** light should be on. The three lights just mentioned are located on the associated front panel keys.
- B. The power level requested should not be greater than the maximum power specification at a given frequency. If the instrument is sweeping, make sure that the power requested does not exceed the maximum power specification for the entire band or bands that are being swept.
- C. If the output power is unleveled at all power levels and all frequencies, suspect a problem on the A25 ALC Detector board, the A26 Linear Modulator board, or the RF path.

- D. If the power will level at some frequencies and not others while the instrument is sweeping, the SYTM may not be tracking correctly. Try the AUTO TRACKING feature by pressing [SHIFT] [PEAK].
- E. If the power will level at some CW frequencies and not at others, press [PEAK] to optimize the SYTM tracking at the frequency of interest.
- F. If the power is unlevelled in Band 0 (10 MHz to 2.3 GHz) only, suspect a problem in the switching circuits on the A25 ALC Detector board, the A26 Linear Modulator board, the A12 Band 0 detector, or the associated microcircuits.
- G. If the power is unlevelled in bands 1-3 (2.3 GHz to 26.5 GHz) only, suspect a problem in the switching circuits on the A25 ALC Detector board, A26 Linear Modulator board, the All Band 1-4 Detector, or the associated microcircuits.

NOTE

Refer to the ALC Loop Overview in Section III of this volume.

9. OVERMOD ANNUNCIATOR

Overmod indicates that the RF power is turned completely off and a signal (AM or, if instrument is so equipped, Pulse Modulation) is attempting to shut it off even further. Make sure an external AM signal is not exceeding specified voltage limits (the AM input allows a 0 to +-1 volt signal).

10. SRQ ANNUNCIATOR

To understand the **SRQ** annunciator, a brief description of SRQ (Service Request) is necessary. The way the SRQ works is described below:

SRQ is only used when the instrument is connected to an external controller (via HP-1B). The controller picks one or more conditions under which the HP 8340A will send out a service request (SRQ). The controller then programs the instrument to send an SRQ when one of these conditions occurs.

When one of the programmed conditions occurs, the HP 8340A sends out an SRQ signal and activates the **SRQ** annunciator.

When the controller responds to the SRQ (by doing a serial poll command) the HP 8340A turns the **SRQ** annunciator off. This entire process takes but a fraction of a second, so the time the **SRQ** annunciator stays on is normally very brief.

SRQ Annunciator Stays On

If the **SRQ** annunciator goes on and stays on it usually indicates that one of the following conditions exists:

- A. IF THE HP 8340A IS CONNECTED TO AN EXTERNAL CONTROLLER: the computer controller is not able to service the SRQ interrupt. This problem is usually caused by the controller being stuck in a loop, etc, and not by a fault in the instrument.

- B. IF THE HP 8340A IS NOT CONNECTED TO AN EXTERNAL CONTROLLER:
The **SRQ** annunciator usually stays on when a controller has programmed the instrument to send an SRQ, and has subsequently been disconnected.